

Au OBD2 CAN Simulator

User Manual

Rev. B

Au Group Electronics

August 2023



Table of Contents

CHAPTER - 1	INTRODUCTION	4
1.1	MAJOR FEATURES	4
1.2	HARDWARE FEATURES	5
1.3	TYPICAL OBD2 CAN NETWORK TOPOLOGY WITH AU OBD2 SIMULATOR	6
1.4	ELEVEN EDITIONS OF AU OBD2 CAN SIMULATORS.....	7
1.4.1	<i>Non-Plus Editions</i>	7
1.4.2	<i>Plus Editions</i>	7
1.4.3	<i>Script Editions</i>	7
1.5	FUNCTIONS OF EACH EDITION	8
1.5.1	<i>Value Package editions</i>	8
1.5.2	<i>Engine Basic editions</i>	9
1.5.3	<i>Engine Premium editions</i>	9
1.5.4	<i>Vehicle Platinum editions</i>	9
1.6	LICENSE /FIRMWARE UPGRADE AND ANNUAL SUPPORT SERVICE.....	9
1.7	ORDER INFORMATION.....	10
CHAPTER - 2	SUPPORTED DIAGNOSTIC SERVICES AND PARAMETERS	11
2.1	VALUE PACKAGE EDITIONS	11
2.2	ENGINE BASIC EDITIONS.....	11
2.3	ENGINE PREMIUM EDITIONS	14
2.4	VEHICLE PLATINUM EDITIONS	14
CHAPTER - 3	OPERATING INSTRUCTIONS.....	16
3.1	POWER ON.....	16
3.2	OPERATING MODE (STATIC/DYNAMIC).....	16
3.3	PUSH BUTTON FUNCTIONS	16
3.4	LED INDICATOR STATUS.....	18
CHAPTER - 4	AU OBD2 CAN SIMULATOR REMOTE TERMINAL GUI.....	21
4.1	CONTROL PANEL – STEP 1: CONNECT TO OBD2 CAN SIMULATOR	22
4.1.1.	<i>Device Information</i>	22
4.1.2.	<i>Device Settings</i>	23
4.2	CONTROL PANEL – STEP 2: REMOTE CONTROL AU OBD2 CAN SIMULATOR.....	23
4.3	CONTROL PANEL – STEP 3: SCRIPT CONTROL	24
4.3.1	<i>Turn on Script control</i>	25
4.3.2	<i>Generate Script Command</i>	25
4.3.3	<i>Script Syntax</i>	26
4.3.4	<i>Example of script command segments</i>	26
4.3.5	<i>Run script from a file</i>	27
4.4	DISPLAY PANEL.....	28
4.4.1.	<i>Value Package Parameters</i>	28
4.4.2.	<i>Engine Basic Parameters</i>	29
4.4.3.	<i>Engine Premium Parameters</i>	31
4.4.3.1.	<i>Confirmed DTC, Pending DTC, and Permanent DTC</i>	31
4.4.3.2.	<i>Engine Freeze Frames for Classic OBD</i>	32
4.4.3.3.	<i>Engine Freeze Frames and other services \$19 for OBDonUDS</i>	32
4.4.4.	<i>Vehicle Platinum Parameters</i>	33
CHAPTER - 5	DATA CONFIGURATION	34
5.1	SIMULATION STATUS AT EACH CONTROL STEP	34
5.2	VALUE PACKAGE ENGINE PARAMETERS SIMULATION VALUES	36
5.3	OTHER ENGINE PARAMETERS SIMULATION VALUES	38
5.4	TRANSMISSION PARAMETERS SIMULATION VALUES.....	50
5.5	ABS PARAMETERS SIMULATION VALUES	54
CHAPTER - 6	APPENDIX.....	56



6.1 APPENDIX A - REMOTE TERMINAL GUI INSTALLATION GUIDE.....56

 6.1.1 *What is needed?*56

 6.1.2 *Step by step installation guide*.....56

6.2 APPENDIX B - HOW TO UPGRADE AU OBD2 CAN SIMULATOR LICENSE58

 6.2.1 *What is needed?*58

 6.2.2 *Step by Step License Upgrading Procedure*.....58

6.3 APPENDIX C - HOW TO INSTALL AU PIC BOOT-LOADER60

Chapter - 1 Introduction

Au OBD2 CAN Simulators are a family of devices which are capable of generating OBD2 CAN signals based on SAE J1979 (classic OBD) and SAE J1979-2 (OBDonUDS). The generated OBD2 CAN signals can be used for automotive OBD2 related product development, validation, assembly line testing, incoming inspection, business demonstration, etc.

For SAE J1979 (Classic OBD), service \$01, \$02, \$03, \$04, \$05, \$06, \$07, \$08, \$09, \$0A are supported.

For SAE J1979-2 (OBDonUDS), service (\$22 \$F4xx/F5xx/F7xx), (\$19 \$04), (\$19 \$42330802), (\$14), (\$22 \$F6xx), (\$19 \$42330402), (\$31), (\$22 \$F8xx), (\$19 \$1A), (\$19 \$06), (\$19 \$55), (\$19 \$56) are supported.

Note: FW 0.1B Build 07262023-01 has the ITID \$17, \$1A, \$1B, and \$1C implemented for Service \$09 /\$22 \$F8xx. These parameters are for developing or testing devices related to EU Regulation 2017/1151: "On Board Fuel Consumption Monitoring (OBFCM)"



Figure 1-1

1.1 Major Features

Au Group Electronics OBD2 CAN Simulator product line offers a great price and value at any level starting with the Value Package edition.

- Supports two OBD protocols: Classic OBD (SAE J1979) and OBDonUDS (SAE J1979-2) protocols
- Supports two CAN ID: standard (11-bit) and extended (29-bit) CAN ID
- Supports two CAN baud rate: 250K and 500K CAN baud rate
- Supports two Ignition styles: Spark ignition and Compression ignition.
- OBDonUDS protocol supports both DTC format: SAE J1939-73 and J2012-DA (Engine Premium editions and up)
- CAN bus can be turned on/off by a check box on GUI or push buttons on the device.
- Two VIN style are supported, one button (on the GUI) to switch between one-VIN style or multiple VIN style.
- Easy to use: No software setup experience or CAN/OBD2 CAN protocol configuration skills are required. After a network is connected, apply power and it will dynamically generate OBD2 CAN data when in dynamic mode.
- Static mode or Dynamic Mode
 - Static mode outputs static OBD2 CAN signals; signals can be changed manually
 - Dynamic mode automatically changes the output value of SAE OBD2 CAN signals
 - Two modes can be switched easily (*by pressing and holding both "Menu" and "Up" buttons until a long beep is heard*)
- Capable of supporting up to 3 ECUs: Engine, Transmission, and ABS
- Multiple CAN Source Addresses can be selected for each ECU
- Individual DTC on/off control for each ECU (Engine premium and above editions)
- Smart features: Recalls last operating mode at power-on, and capable of generating dynamic data.
- PC Remote Terminal GUI:
 - Connects Au OBD2 CAN Simulator to a PC through serial communication.
 - Displays the simulator device information, configure and displays simulator settings, and performs license upgrading.
 - Displays simulated OBD2 signals on a computer screen for "Plus" editions and "Script" editions.
 - Provides script control capabilities for "Script" editions.
- Script control capabilities (for "Script" editions only):
 - Capable of setting 6 parameters to any value in the SAE J1979 and J1979-2 specification allowed range, generating script, and running script file.

- The script can be delayed and repeated running with or without white noise.
- One-button to switch on/off script control on GUI
- One-button to switch on/off white noise feature on GUI.
- In-field license upgrade feature.
- In-field firmware update capability
- Annual support and minor upgrade services are available
- Custom firmware and GUI modification is available upon request

1.2 Hardware Features

- Power supply: +12V/+24V DC nominal (recommend: +14.2V~+28.4V DC), 250mA max
- One internal 120 ohm load resistor is included
- Compact size: 4-1/8" L X 1-3/4"W X 7/8"H
- Enclosure color: Black or PC white
- Operating temperature: -4 °F to 185 °F (-20 °C to 85 °C)
- 1 buzzer: Can be muted or enabled
- 9 LED indicators: Power, Range, DTC, ▼0%, 20%, 40%, 60%, 80%, ▲100%
- 3 push buttons: Menu, Down, Up
- TVS (Transient Voltage Suppressor) protection on CAN bus
- 1 DB9 Male "BUS" Interface: For power supply and CAN/OBD2 CAN network connection (Figure 1 – 2)
- 1 RS232 interface: for CAN baud rate setting, Source address configuration, in-field firmware update, license management, and computer remote control (for **Plus** editions and **script** editions) (Figure 1 – 3).



Pin 1: GND Pin 6: CAN-L
Pin 5: +12V DC Pin 7: CAN-H

Figure 1-2



Pin 2: To PC RXD Pin 3: from PC TXD
Pin 5: GND

Figure 1-3

Au OBD2 CAN Simulator can be connected to a PC through an RS232 serial extension cable (part # CBL-RS232-01), as shown in Figure 1-4.

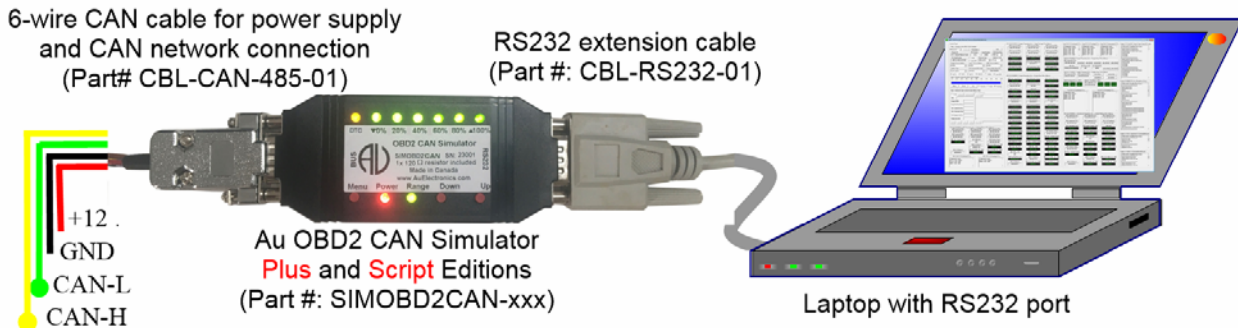

Figure 1-4

For a PC with USB port, a USB to RS232 serial convert cable (part # CBL-USB-232) can be used (Figure 1-5).



Figure 1-5

1.3 Typical OBD2 CAN Network Topology with Au OBD2 Simulator

A typical OBD2 CAN network topology with an Au SAE OBD2 Simulator is illustrated in Figure 1-6.

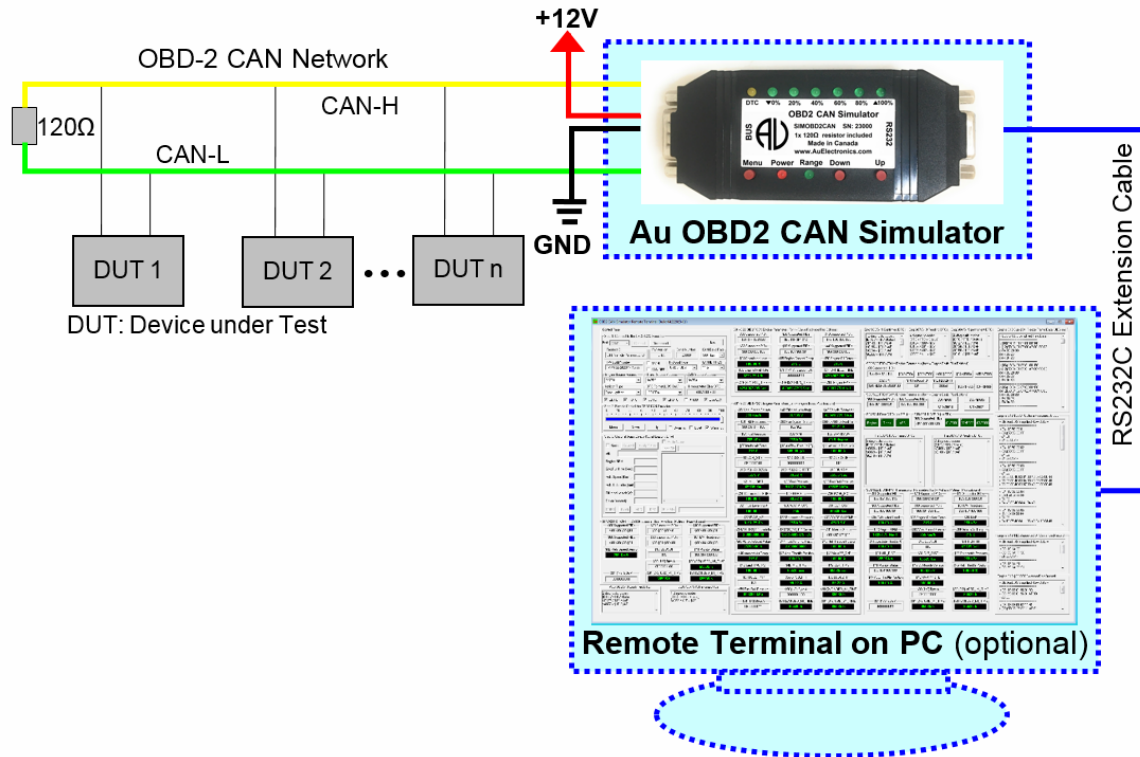



Figure 1-6

The following cables and power supply are optional components for different applications. They are sold separately.

Table 1-1 Necessary accessories for Au OBD2 CAN Simulator

<p>CBL-CAN-485-01</p> 	<p>A 6-wire color-coded cable used for Au J1939, OBD2 CAN and Au J1708 devices. One end of the cable is a DB9 female connector, designed to mate with Au devices on the BUS side.</p> <p>The other side of the cable is a pigtail with 3 pairs of twisted color-coded wires:</p> <p>Red wire: Power supply, e.g. +12V DC Black wire: Ground Yellow wire: CAN High Green wire: CAN Low Violet: J1708A+ Brown: J1708B-</p>
<p>CBL-OB2-CAN-02</p> 	<p>CBL-OB2-CAN-02 cable provides power supply and OBD2 CAN network connection similar to what's available on trucks, RVs and School buses.</p> <p>One end is a DB9 female connector, which mates with the Au OBD2 CAN Simulator. The other end is an OBD2 receptacle housing.</p> <p>It also includes a power Supply Jacket (2.1 mm Positive center), which can supply power to all devices connected on the cable.</p> <p>Cable length: >=6 inch.</p>
<p>CBL-USB-232</p> 	<ul style="list-style-type: none"> • The USB to Serial Converter cable can be used to connect computer USB port to Au OBD2 CAN / J1708 products (on RS232 Side). • Compatible with Vista, XP, Win7, and Win10. Three LEDs (Power, TX and RX) are included. Power LED is on when USB power is supplied. TX LED will blink when COM port is transmitting. RX LED will blink when COM port is receiving. • Compatible with all Au Group Electronics system products, OBD2 CAN Simulators, J1708 Simulators, FMS Simulators, NMEA2000 Simulators, OBD2 CAN /J1708 Interpreters, OBD2 CAN/J1708 MCS, OBD2 CAN/J1708 DCS, OBD2 CAN/J1708 Gateways.

<p>CBL-RS232-01</p> 	<p>RS232 Serial extension cable can be used to connect computer Serial port to Au OBD2 CAN / J1708 products (on RS232 Side).</p> <ul style="list-style-type: none"> ● Fully shielded to prevent unwanted EMI/RFI ● Fully molded connectors with thumbscrews provide a quick and easy connection every time ● Connectors: DB9 Male to DB9 Female ● Cable length: 6 feet <p>All 9 connector pins are wired straight through</p>
<p>PWR-912V-CP</p> 	<p>Wall mounted AC/DC power supply can supply power to all devices connected to CBL-J1708-02 or CBL-CAN-485-02D.</p> <ul style="list-style-type: none"> ● Positive center ● Connector style: 2.1mm I.D. x 5.5mm O.D. x 12mm Female (compatible with the power jacket of CBL-J1708-02 and CBL-CAN-485-02) ● Voltage input: 110~120V AC Input ● Voltage output: 12V DC ● Current output: 500mA Max. ● Inrush current: 40A Maximum ● Power: 6.0W ● Line Regulation: +/- 2% ● Load Regulation: +/- 5%

1.4 Eleven Editions of Au OBD2 CAN Simulators

Eleven editions of Au OBD2 CAN Simulator are available: 4 Non-Plus editions, 4 Plus editions, and 3 Script editions.

1.4.1 Non-Plus Editions

Au OBD2 CAN Simulator **Non-Plus** edition can be operated independently without a PC. Full range of OBD2 CAN signals can be generated by controlling 3 push buttons.

Simulator settings need to use the remote terminal GUI: CAN Baud rate, CAN On/Off control, Classic/UDS Protocol Type selection, 11/29 bit CAN ID selection, and Source address. The device settings will be saved on the device, power on / off will not affect the settings.

It is highly recommend for all non-plus edition users to get the CBL-USB-232 cable for device setting and license upgrading purposes.

1.4.2 Plus Editions

Au OBD2 CAN Simulator **Plus** editions have all functions of **Non-Plus** editions, with the addition of a **PC Remote Terminal GUI**. Like the Non-Plus editions, all the Plus editions can still work independently without a PC. The "Remote Terminal GUI" connects Au OBD2 CAN Simulator to a PC through serial communication. It displays the simulator device information, alters and displays the simulator settings, and performs license upgrading for all editions. It also shows simulated OBD2 CAN signals on a computer screen for "Plus" editions and "script" editions.

Plus Edition = Non-Plus Edition + PC Remote Terminal GUI Program

1.4.3 Script Editions

Au OBD2 CAN Simulator **Script** editions have all the functions of **Plus** editions, with the addition of **script control capabilities**. Detailed information can be found in chapter 4.

Script Edition = Plus Edition + Script control capabilities

- Script control sets six parameters to any value in the SAE-J1979 or SAE J1979-2 specification allowed range: Vehicle Identification Number (VIN), Engine RPM, Engine Run Time, Vehicle Speed, Vehicle Odometer, and Control Module Voltage.
- Engine Run Time can be set with an initial value, then it will accumulate over time.
- Vehicle Odometer can be set with an initial value, it will accumulate base on vehicle speed and runtime.
- Four buttons to generate frequently used script segments which mimic an vehicle's key on engine off, Cranking, Acceleration, and Deceleration.
- Script control can load and run a saved script file.
- The script can be delayed and repeated with or without white noise.

- A script command can switch CAN bus on/off.
- A script command from script file can adjust the control step value.
- One button on GUI to switch on/off Script control
- One button on GUI to switch on/off White noise feature.

1.5 Functions of Each Edition

Functions of each edition of OBD2 CAN Simulator are summarized in Table 1-2.

Table 1 – 2 Basic functions of each edition

ECU	Classic OBD (SAE J1979)	OBDonUDS (SAE J1979-2)	Value Package	Engine Basic	Engine Premium	Vehicle Platinum
Engine	Service \$01	Service \$22 Sub F4/F5/F7XX	13 supported PID	69 supported PID	69 supported PID	69 supported PID
	Service \$02	Service \$19 Sub \$04	X	#00 / no freeze frame	5 Freeze Frame	5 Freeze Frame
	Service \$03	Service \$19 Sub \$42330802	X	0 Confirmed DTC	12 Confirmed DTC	12 Confirmed DTC
	Service \$04	Service \$14	X	X	V	V
	Service \$06	Service \$22 Sub \$F6XX	X	6 supported MID	6 supported MID	6 supported MID
	Service \$07	Service \$19 Sub \$42330402	X	0 Pending DTC	4 Pending DTC	4 Pending DTC
	Service \$08	Service \$31	X	4 supported TID	4 supported TID	4 supported TID
	Service \$09	Service \$22 Sub \$F8XX	X	31 supported ITID	31 supported ITID	31 supported ITID
	Service \$0A	Service \$19 Sub \$55	X	0 Permanent DTC	4 Permanent DTC	4 Permanent DTC
		Service \$19 Sub \$1A	X	X	V	V
		Service \$19 Sub \$06	X	X	V	V
		Service \$19 Sub \$56	X	X	V	V
Transmission	Service \$01	Service \$22 Sub F4/F5/F7XX	X	X	X	22 supported PID
	Service \$03	Service \$19 Sub \$42330802	X	X	X	3 confirmed DTC
	Service \$04	Service \$14	X	X	X	V
	Service \$07	Service \$19 Sub \$42330402	X	X	X	2 pending DTC
ABS	Service \$01	Service \$22 Sub F4/F5/F7XX	X	X	X	7 supported PID
	Service \$03	Service \$19 Sub \$42330802	X	X	X	2 Confirmed DTC
	Service \$04	Service \$14	X	X	X	V
	Service \$07	Service \$19 Sub \$42330402	X	X	X	1 Pending DTC

1.5.1 Value Package editions

- Support 1 ECU: Engine
- Support 1 diagnostic service: Service 01(Classic OBD) / service 22 (OBDonUDS)
- 13 supported PIDs for Service \$01(Classic OBD) /service \$22 (OBDonUDS) from Engine.
- "Script" control capability is **NOT** available for Value Package editions

1.5.2 Engine Basic editions

- Support 1 ECU: Engine
- Support 8 diagnostic services for both classic OBD and OBDOnUDS.
- 69 supported PIDs for Service \$01(Classic OBD) / service \$22 (OBDOnUDS) from Engine.
- 6 supported MIDs for Service \$06 (Classic OBD) / service \$22 (OBDOnUDS) from Engine.
- 4 supported TIDs for Service \$08 (Classic OBD) / service \$31 (OBDOnUDS) from Engine.
- 31 supported ITIDs for Service \$09 (Classic OBD) / service \$22 (OBDOnUDS) from Engine.
- Supports **Zero** frame DTC
- "Script" control capability is available for **Engine Basic Script** edition

1.5.3 Engine Premium editions

- Supports 1 ECU: Engine
- Supports 9 diagnostic services for Engine classic OBD
- Supports 12 diagnostic services for Engine OBDOnUDS.
- 69 supported PIDs for Service \$01(Classic OBD) / service \$22 (OBDOnUDS) from Engine.
- 6 supported MIDs for Service \$06 (Classic OBD) / service \$22 (OBDOnUDS) from Engine.
- 4 supported TIDs for Service \$08 (Classic OBD) / service \$31 (OBDOnUDS) from Engine.
- 31 supported ITIDs for Service \$09 (Classic OBD) / service \$22 (OBDOnUDS) from Engine.
- Supports confirmed DTC, pending DTC, and permanent DTC from Engine (Service \$03, \$07, \$0A).
- Supports up to 5 freeze frames
- "Script" control capability is available for **Engine Premium Script** edition

1.5.4 Vehicle Platinum editions

- Supports 3 ECUs: Engine, Transmission, and ABS
- Supports 9 diagnostic services for Engine classic OBD
- Supports 12 diagnostic services for Engine OBDOnUDS.
- 69 supported PIDs for Service \$01(Classic OBD) / service \$22 (OBDOnUDS) from Engine.
- 22 supported PIDs for Service \$01(Classic OBD) / service \$22 (OBDOnUDS) for Transmission.
- 7 supported PIDs for Service \$01(Classic OBD) / service \$22 (OBDOnUDS) for for ABS.
- 6 supported MIDs for Service \$06 (Classic OBD) / service \$22 (OBDOnUDS) from Engine.
- 4 supported TIDs for Service \$08 (Classic OBD) / service \$31 (OBDOnUDS) from Engine.
- 31 supported ITID for Service \$09 (Classic OBD) / service \$22 (OBDOnUDS) from Engine.
- Supports confirmed DTC, pending DTC, and permanent DTC for Engine
- Supports confirmed DTC and pending DTC for Transmission
- Supports confirmed DTC and pending DTC for ABS
- "Script" control capability is available for **Vehicle Platinum Script** Edition

1.6 License /Firmware Upgrade and Annual Support Service

- Simulator license can be in-field upgraded to higher editions. "Au License Management" in the remote terminal GUI provides the in-field license upgrading capability.
 - Value Package editions can be upgraded to Engine Basic editions (part #: LIC-OBD2-001).
 - Engine Basic editions can be upgraded to Engine Premium editions (part #: LIC-OBD2-002).
 - Engine Premium editions can be upgraded to Vehicle Platinum editions (part #: LIC-OBD2-003).
 - "Non-Plus" editions are able to be upgraded to plus editions (part #: LIC-OBD2-004).
 - Engine Basic "plus" editions are able to be upgraded to "Script" editions (part #: LIC-OBD2-005).
- Firmware can be in-field updated with the **Au PIC Boot-loader**
 - Firmware update code or customized codes can be re-programmed to gain new or special features.
 - "Au PIC Boot-loader" provides the in-field firmware upgrading capability.
 - A 12-month Firmware updating service is available (part #: SVS-SIMOBD2CAN) to purchase for Au OBD2 CAN Simulator, this service also includes priority technical support for the related products. You may purchase SVS-SIMOBD2CAN in one-year increments or purchase at any time, it is not necessary to purchase it continuously.

Part numbers for license upgrading and annual service for the 11 editions of Au SAE OBD2 CAN Simulator are summarized in Figure 1 - 7.

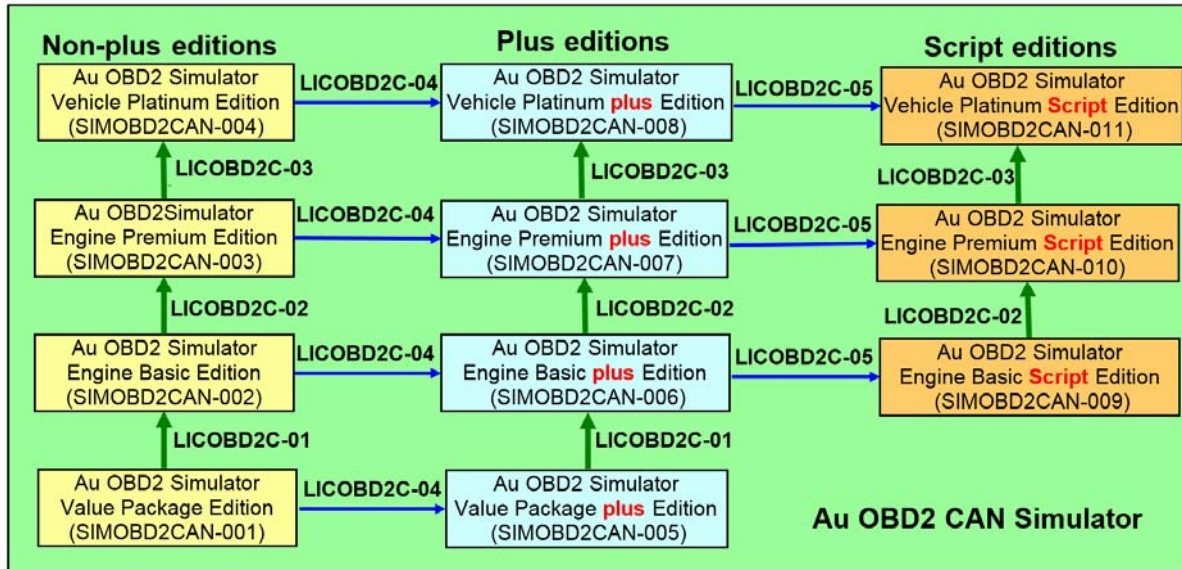

Figure 1 - 7

1.7 Order information

All of Au OBD2 CAN Simulators, accessories, and license upgrades are available to order at Au Group Electronics website: <https://www.auelectronics.com/System-SIMOBD2CAN.htm>

The part# for 11 editions of Au SAE OBD2 CAN Simulator are summarized in Table 1-3.

Table 1 - 3 Part# for 11 editions of Au OBD2 CAN Simulator and accessories

Au SAE OBD2 CAN Simulators 1.00A Editions		Part#
Non-Plus Edition	Au SAE OBD2 CAN Simulator (Value Package Non-Plus Edition)	SIMOBD2CAN-001
	Au SAE OBD2 CAN Simulator (Engine Basic Non-Plus Edition)	SIMOBD2CAN-002
	Au SAE OBD2 CAN Simulator (Engine Premium Non-Plus Edition)	SIMOBD2CAN-003
	Au SAE OBD2 CAN Simulator (Vehicle Platinum Non-Plus Edition)	SIMOBD2CAN-004
Plus Edition	Au SAE OBD2 CAN Simulator (Value Package Plus Edition)	SIMOBD2CAN-005
	Au SAE OBD2 CAN Simulator (Engine Basic Plus Edition)	SIMOBD2CAN-006
	Au SAE OBD2 CAN Simulator (Engine Premium Plus Edition)	SIMOBD2CAN-007
	Au SAE OBD2 CAN Simulator (Vehicle Platinum Plus Edition)	SIMOBD2CAN-008
Script Edition	Au SAE OBD2 CAN Simulator (Engine Basic Script Edition)	SIMOBD2CAN-009
	Au SAE OBD2 CAN Simulator (Engine Premium Script Edition)	SIMOBD2CAN-010
	Au SAE OBD2 CAN Simulator (Vehicle Platinum Script Edition)	SIMOBD2CAN-011
Accessories	6-wire cable for power supply and OBD2 CAN/J1708 network connection	CBL-CAN-485-01
	A cable with a power jacket, a DB9 female connector, and an OBD2 receptacle housing	CBL-OBD2-CAN-02
	14V Wall mount AC/DC power supply, positive center, 110V input	PWR-912V-CP
	RS232 Serial Extension Cable (for computer with RS232 port)	CBL-RS232-01
	USB to RS232 Serial Convert Cable (for computer with USB port)	CBL-USB-232
Service	12-month firmware update service & priority technical support for Au OBD2 CAN Simulator	SVS-SIMOBD2CAN
License Upgrade	From Value Package Edition to Engine Basic Edition	LICOB2C-01
	From Engine Basic Edition to Engine Premium Edition	LICOB2C-02
	From Engine Premium Edition to Vehicle Platinum Edition	LICOB2C-03
	From Non-Plus Edition to Plus Edition	LICOB2C-04
	From Plus Edition to Script Edition	LICOB2C-05

Chapter - 2 Supported Diagnostic Services and Parameters

2.1 Value Package editions

Au OBD2 CAN Simulator Value Package editions support:

- 1 ECU: Engine,
- 1 diagnostic service: Service \$01(Classic OBD) / service \$22 (OBDonUDS) from Engine,
- 13 supported PIDs for Service \$01(Classic OBD) / service \$22 (OBDonUDS) from Engine.

Table 2 – 1 Service List (Value Package editions)

#	Service # (Classic OBD / OBDonUDS)	Service Definition
1	Service \$01 / Service \$22	Request Current Powertrain Diagnostic Data

Table 2 – 2 Service \$01 Supported PID List (Value Package editions)

#	PID # (Classic OBD / OBDonUDS)	Parameter ID (PID) Description
1 ~ 4	PID \$00/20/40/60 / \$F400/F420/F440/F460	Supported PID (\$00 – \$80)
5	PID \$04 / \$F404	Calculated LOAD Value
6	PID \$05 / \$F405	Engine Coolant Temperature
7	PID \$0C / \$F40C	Engine RPM
8	PID \$5C / \$F45C	Engine Oil Temperature
9	PID \$5E / \$F45E	Engine Fuel Rate
10 - 13	PID \$7F / \$F47F	Support of Engine Run Time Total Engine Run Time Total Idle Run Time Total Run Time With PTO Active

2.2 Engine Basic editions

Au OBD2 CAN Simulator Engine Basic editions support:

- 1 ECU (Engine)
- 8 diagnostic services with zero DTC (Table 2 – 3)
- 69 supported PIDs for Service \$01(Classic OBD) / service \$22 (OBDonUDS) from Engine (Table 2 – 4).
- 6 supported MIDs for Service \$06 (Classic OBD) / service \$22 (OBDonUDS) from Engine (Table 2 – 5).
- 4 supported TIDs for Service \$08 (Classic OBD) / service \$31 (OBDonUDS) from Engine (Table 2 – 6).
- 31 supported ITIDs for Service \$09 (Classic OBD) / service \$22 (OBDonUDS) from Engine (Table 2 – 7).

Table 2 – 3 Supported Services List by Engine Basic and above editions

#	Service # (Classic / OBDonUDS)	Service Definition
1	Service \$01 / Service \$22	Request Current Powertrain Diagnostic Data
2	Service \$02 / Service \$19 sub \$04	Freeze Frame \$00 shows no freeze frame
3	Service \$03 / Service \$19 Sub \$42	No confirmed DTC
4	Service \$06 / Service \$22 - MID	Request On-Board monitoring test results for specific monitored systems
5	Service \$07 / Service \$19 Sub \$42	No pending DTC
6	Service \$08 / Service \$31	Request Control of On-Board System, Test or Component
7	Service \$09 / Service \$22 - ITID	Request Vehicle Information
8	Service \$0A / Service \$19 Sub \$55	No permanent DTC

Table 2 – 4 Supported PIDs for Service \$01 / Service \$22 from Engine (Engine Basic and above editions - 69)

#	PID# (Classic OBD / OBDonUDS)	PID Description (Engine)
1 ~ 6	PID \$00/20/40/60/80/A0 / \$F400/F420/F440/F460/F480/F4A0	Supported PID (\$00 - A0)
7	PID \$01/ \$F401	I/M Readiness Data
8	PID \$03/ \$F403	Fuel system status
9	PID \$04/ \$F404	Calculated LOAD Value
10	PID \$05/ \$F405	Engine Coolant Temperature
11	PID \$06/ \$F406	Short Term Fuel Trim - Bank 1
12	PID \$07/ \$F407	Long Term Fuel Trim - Bank 1

13	PID \$08/ \$F408	Short Term Fuel Trim - Bank 2
14	PID \$09/ \$F409	Long Term Fuel Trim - Bank 2
15	PID \$0A/ \$F40A	Fuel Pressure (gauge)
16	PID \$0B/ \$F40B	Intake Manifold Absolute Pressure
17	PID \$0C/ \$F40C	Engine RPM
18	PID \$0D/ \$F40D	Vehicle Speed Sensor
19	PID \$0E/ \$F40E	Ignition Timing Advance for #1 Cylinder
20	PID \$0F/ \$F40F	Intake Air Temperature
21	PID \$10/ \$F410	Air Flow Rate from Mass Air Flow Sensor
22	PID \$11/ \$F411	Absolute Throttle Position
23	PID \$12/ \$F412	Commanded Secondary Air Status
24	PID \$13/ \$F413	Location of oxygen sensors
25	PID \$15/ \$F415	O2 Sensor and SHRFT Bank 1, Sensor 2
26	PID \$19/ \$F419	O2 Sensor and SHRFT Bank 2, Sensor 2
27	PID \$1C/ \$F41C	OBD requirements for vehicle or engine
28	PID \$1F/ \$F41F	Time Since Engine Start
29	PID \$21/ \$F421	Distance Traveled While MIL is Activated
30	PID \$22/ \$F422	Fuel Pressure relative to manifold vacuum
31	PID \$23/ \$F423	Fuel Rail Pressure
32	PID \$2C/ \$F42C	Commanded EGR
33	PID \$2D/ \$F42D	EGR Error
34	PID \$2E/ \$F42E	Commanded Evaporative Purge
35	PID \$2F/ \$F42F	Fuel Level Input
36	PID \$30/ \$F430	Number of warm-ups since DTCs cleared
37	PID \$31/ \$F431	Distance traveled since DTCs cleared
38	PID \$32/ \$F432	Evap System Vapor Pressure
39	PID \$33/ \$F433	Barometric Pressure
40	PID \$34/ \$F434	Wide Ratio O2 Lambda value and Current, Bank 1, Sensor 1
41	PID \$38/ \$F438	Wide Ratio O2 Lambda value and Current, Bank 2, Sensor 1
42	PID \$3C/ \$F43C	Catalyst Temperature Bank 1, Sensor 1
43	PID \$3D/ \$F43D	Catalyst Temperature Bank 2, Sensor 1
44	PID \$3E/ \$F43E	Catalyst Temperature Bank 1, Sensor 2
45	PID \$41/ \$F441	Monitor status this driving cycle
46	PID \$42/ \$F442	Control module voltage
47	PID \$43/ \$F443	Absolute Load Value
48	PID \$44/ \$F444	Fuel/Air Commanded Equivalence Ratio
49	PID \$45/ \$F445	Relative Throttle Position
50	PID \$46/ \$F446	Ambient Air Temperature
51	PID \$47/ \$F447	Absolute Throttle Position B
52	PID \$49/ \$F449	Accelerator Pedal Position D
53	PID \$4A/ \$F44A	Accelerator Pedal Position E
54	PID \$4C/ \$F44C	Commanded Throttle Actuator Control
55	PID \$4D/ \$F44D	Engine run time while MIL activated
56	PID \$4E/ \$F44E	Engine run time since DTCs cleared
57	PID \$51/ \$F451	Type of fuel currently being utilized by the vehicle
58	PID \$55/ \$F455	Short Term Secondary O2 Sensor Fuel Trim – Bank 1
59	PID \$56/ \$F456	Long Term Secondary O2 Sensor Fuel Trim – Bank 1
60	PID \$59/ \$F459	Fuel Rail Pressure (absolute)
61	PID \$5C/ \$F45C	Engine Oil Temperature
62	PID \$5E/ \$F45E	Engine Fuel Rate
63 - 66	PID \$7F/ \$F47F	Support of Engine Run Time, Total Engine Run Time Total Idle Run Time, Total Run Time With PTO Active
67		WWH-OB2 Vehicle OBD System Information
68		WWH-OB2 ECU OBD System Information
69		Vehicle Odometer Reading

Table 2 - 5 Supported MID for Service \$06 /Service \$22 from Engine (6)

#	MID #	Monitor ID (MID) Description
1	MID \$00/ \$F600	Supported PIDs
2	MID \$20/ \$F620	Supported PIDs
3	MID \$01/ \$F601	Exhaust Gas Sensor Monitor Bank 1 - Sensor 1
4	MID \$05/ \$F605	Exhaust Gas Sensor Monitor Bank 2 - Sensor 1
5	MID \$10/ F610	Exhaust Gas Sensor Monitor Bank 4 - Sensor 4
6	MID \$21/ \$F621	Catalyst Monitor Bank 1

Table 2 - 6 Supported TID for Service \$08 /Service \$31 from Engine (6)

#	TID #	Test ID (TID) Description
1	TID \$00/\$E000	Supported TIDs
2	TID \$01/\$E001	Evaporative system leak test
3	TID \$02/\$E002	Particulate Filter Regeneration
4	TID \$03/\$E003	Inducement System Re-initialization

Table 2 - 7 Supported ITID for Service \$09 /Service \$22 from Engine (31)

#	ITID #	Info-Type ID (ITID) Description
1	ITID \$00/\$F800	Supported ITID
2	ITID \$02/\$F802	Vehicle Identification Number (VIN)
3	ITID \$04/\$F804	Calibration Identifications (CALID)
4	ITID \$06/\$F806	Calibration Verification Numbers(CVN)
5	ITID \$08/\$F808	In-use Performance Tracking for spark ignition engines
6	ITID \$0A/\$F80A	ECUNAME
7	ITID \$0B/\$F80B	In-use Performance Tracking for compression ignition engines
8	ITID \$0D/\$F80D	Engine Serial Number (ESN)
9	ITID \$0F/\$F80F	Exhaust Regulation Or Type Approval Number (EROTAN)
10	ITID \$10/\$F810	Protocol Identification
11	ITID \$12/\$F812	Fueled Engine Operation Ignition Cycle Counter
12 ~ 15	ITID \$17/\$F817	Vehicle Operation Data - Distance/Fuel Used: Total Distance Traveled (Recent) Total Distance Traveled (Lifetime) Total Fuel Consumed (Recent) Total Fuel Consumed (Lifetime)
16 ~21	ITID \$1A/\$F81A	Plug-in Hybrid Vehicle Distance Data: Total distance traveled in charge depleting operation with engine off (Recent) Total distance traveled in charge depleting operation with engine off (Lifetime) Total distance traveled in charge depleting operation with engine running (Recent) Total distance traveled in charge depleting operation with engine running (Lifetime) Total distance traveled in driver-selectable charge increasing operation (Recent) Total distance traveled in driver-selectable charge increasing operation (Lifetime)
22 ~ 25	ITID \$1B/\$F81B	Plug-in Hybrid Vehicle Fuel Data: Total fuel consumed in charge depleting operation (Recent) Total fuel consumed in charge depleting operation (Lifetime) Total fuel consumed in driver-selectable charge increasing operation (Recent) Total fuel consumed in driver-selectable charge increasing operation (Lifetime)
26 ~ 31	ITID \$1C/\$F81C	Plug-in Hybrid Vehicle Grid Data: Total grid energy consumed in charge depleting operation with engine off (Recent) Total grid energy consumed in charge depleting operation with engine off (Lifetime) Total grid energy consumed in charge depleting operation with engine running (Recent) Total grid energy consumed in charge depleting operation with engine running (Lifetime) Total grid energy into the battery (Recent) Total grid energy into the battery (Lifetime)

2.3 Engine Premium editions

Au OBD2 CAN Simulator Engine Premium editions support:

- 1 ECU: Engine
- **9 diagnostic services from Engine classic OBD**
- **12 diagnostic services from Engine OBDOnUDS.**
- **Supports confirmed DTC, pending DTC, and permanent DTC from Engine (Service \$03, \$07, \$0A).**
- 69 supported PIDs for Service \$01(Classic OBD) / service \$22 (OBDOnUDS) from Engine (Table 2 – 4).
- 6 supported MIDs for Service \$06 (Classic OBD) / service \$22 (OBDOnUDS) from Engine (Table 2 – 5).
- 4 supported TIDs for Service \$08 (Classic OBD) / service \$31 (OBDOnUDS) from Engine (Table 2 – 6).
- 31 supported ITIDs for Service \$09 (Classic OBD) / service \$22 (OBDOnUDS) from Engine (Table 2 – 7).

Table 2 – 8 Service List (Engine Premium and above editions)

#	Classic OBD	OBDOnUDS	Diagnostic Service Definition
1	Service \$01	Service \$22	Request Current Powertrain Diagnostic Data
2	Service \$02	Service \$19 Sub \$04	Request Powertrain Freeze Frame Data
3	Service \$03	Service \$19 Sub \$42	Request Emission-Related DTC with confirmed status
4	Service \$04	Service \$14	Clear/Reset Emission-Related Diagnostic Information
5	Service \$06	Service \$22 - MID	Request On-Board Monitoring Test Results for specific monitored systems
6	Service \$07	Service \$19 Sub \$42	Request Emission-Related DTC with Pending Status
7	Service \$08	Service \$31 - TID	Request Control of On-Board System, Test or Component
8	Service \$09	Service \$22 - ITID	Request Vehicle Information
9	Service \$0A	Service \$19 Sub \$55	Request Emission-Related DTC with Permanent Status
10	N/A	Service \$19 Sub \$1A	Request Supported DTCExtendedRecord Information
11	N/A	Service \$19 Sub \$06	Request DTCExtendedDataRecord
12	N/A	Service \$19 Sub \$56	Request DTCs for a ReadinessGroup

2.4 Vehicle Platinum editions

Au OBD2 CAN Simulator Vehicle Platinum editions support:

- 3 ECUs: Engine, Transmission, and ABS
- Supports 9 diagnostic services for Engine classic OBD
- Supports 12 diagnostic services for Engine OBDOnUDS.
- Supports 4 diagnostic services for Transmission and ABS (Table 2 – 10).
- 69 supported PIDs for Service \$01(Classic OBD) / \$22 (OBDOnUDS) from Engine (Table 2 – 4).
- 22 supported PIDs for Service \$01(Classic OBD) / \$22 (OBDOnUDS) for Transmission(Table 2– 12).
- 7 supported PIDs for Service \$01(Classic OBD) / \$22 (OBDOnUDS) for ABS (Table 2 – 11).
- 6 supported MIDs for Service \$06 (Classic OBD) / \$22 (OBDOnUDS) from Engine (Table 2 – 5).
- 4 supported TIDs for Service \$08 (Classic OBD) / \$31 (OBDOnUDS) from Engine (Table 2 – 6).
- 31 supported ITIDs for Service \$09 (Classic OBD) / \$22 (OBDOnUDS) from Engine (Table 2 – 7).
- Supports confirmed DTC, pending DTC, and permanent DTC for Engine
- Supports confirmed DTC and pending DTC for Transmission
- Supports confirmed DTC and pending DTC for ABS

Table 2 – 9 # of supported Services and parameters for each ECU (Vehicle Platinum Editions)

Supported ECUs	Engine	Transmission	ABS
# of supported Services	Up to 12 (table 2 – 5)	4	4
# of supported PIDs for Service \$01	69	22	7
# of supported MIDs for Service \$06	6	/	/
# of supported TIDs for Service \$08	4	/	/
# of supported ITIDs for Service \$09	31	/	/

Table 2 – 10 Supported Services from ABS and Transmission

#	Classic OBD	OBDonUDS	Diagnostic Service Definition
1	Service \$01	Service \$22	Request Current Powertrain Diagnostic Data
2	Service \$03	Service \$19 Sub \$42	Request Emission-Related DTC with Confirmed Status
3	Service \$04	Service \$14	Clear/Reset Emission-Related Diagnostic Information
4	Service \$07	Service \$19 Sub \$42	Request Emission-Related DTC with Pending Status

Table 2 – 11 Supported PIDs for Service \$01 / Service \$22 from ABS (7)

#	Classic OBD	OBDonUDS	PID Description (ABS)
1	PID \$00	PID \$F400	Supported PID
2	PID \$01	PID \$F401	I/M Readiness Data
3	PID \$0D	PID \$F40D	Vehicle Speed Sensor
4	PID \$1C	PID \$F41C	OBD requirements for vehicle or engine
5	PID \$41	PID \$F441	Monitor status this driving cycle
6	PID \$90	PID \$F490	WWH-OBD Vehicle OBD System Information
7	PID \$91	PID \$F491	WWH-OBD ECU OBD System Information

Table 2 – 12 Supported PIDs for Service \$01 / Service \$22 from Transmission (22)

#	Classic OBD	OBDonUDS	PID Description (Transmission)
1	PID \$00	PID \$F400	Supported PID
2	PID \$01	PID \$F401	I/M Readiness Data
3	PID \$04	PID \$F404	Calculated LOAD Value
4	PID \$05	PID \$F405	Engine Coolant Temperature
5	PID \$0B	PID \$F40B	Intake Manifold Absolute Pressure
6	PID \$0C	PID \$F40C	Engine RPM
7	PID \$0D	PID \$F40D	Vehicle Speed Sensor
8	PID \$0F	PID \$F40F	Intake Air Temperature
9	PID \$11	PID \$F411	Absolute Throttle Position
10	PID \$1C	PID \$F41C	OBD requirements for vehicle or engine
11	PID \$1F	PID \$F41F	Time Since Engine Start
12	PID \$21	PID \$F421	Distance Traveled while MIL is Activated
13	PID \$31	PID \$F431	Distance traveled since DTCs cleared
14	PID \$33	PID \$F433	Barometric Pressure
15	PID \$41	PID \$F441	Monitor status this driving cycle
16	PID \$42	PID \$F442	Control module voltage
17	PID \$45	PID \$F445	Relative Throttle Position
18	PID \$47	PID \$F447	Absolute Throttle Position B
19	PID \$49	PID \$F449	Accelerator Pedal Position D
20	PID \$4A	PID \$F44A	Accelerator Pedal Position E
21	PID \$90	PID \$F490	WWH-OBD Vehicle OBD System Information
22	PID \$91	PID \$F491	WWH-OBD ECU OBD System Information

Chapter - 3 Operating Instructions

All editions of Au OBD2 CAN Simulator can be operated by controlling 3 push buttons. It generates OBD2 CAN signals for product developers, testers, operators and manufacturers.

3.1 Power On

Mate the DB9 female connector of a 6-wire cable (Part#: CBL-CAN-485-01) to the **BUS** side DB9 male connector of Au OBD2 CAN Simulator. Connect the **Red** wire to +12 ~ +14.2V DC power supply, **Black** wire to ground, **Yellow** wire to CAN-H, **Green** wire to CAN-L. The **Power** LED on simulator will light up, and the simulator will resume its last saved operating mode (static mode or dynamic mode).

3.2 Operating Mode (Static/Dynamic)

After power on, Au OBD2 CAN Simulator will work in either **static** mode or **dynamic** mode.

- **Static mode:** Au SAE OBD2 CAN Simulator Gen II generates steady SAE OBD2 CAN signals. In this mode, two push buttons (**Up** and **Down**) can be used to change the data outputs. When no button is pushed, all data will remain constant at its last value.
- **Dynamic mode:** The value of all data will change automatically every second in OBD2 CAN defined range
- To switch between dynamic mode and static mode: Press and hold both **Menu** and **Up** buttons until a long beep is heard if buzzer is enabled; or both the "▼0%" LED and "▲100%" LED flip their status (from on to off or vice versa)

Au OBD2 CAN Simulator equipped with 3 push buttons (**Menu**, **Down**, **Up**) and 9 LEDs (Figure 3-1). Each LED is named after its function.

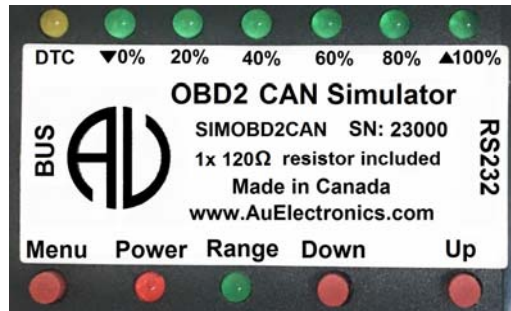

Figure 3-1

3.3 Push Button Functions

- Press **Menu** button:
 - **Menu** button is used to control **Warning** LED on/off. A single press on **Menu** button will turn on the **Warning** LED if the Warning LED was off, and vice versa.
 - The **Menu** button function is available **only** on Engine Premium editions and Vehicle Platinum editions. For Value Package editions and Engine Basic editions, Menu button is not used. Warning LED will be constant off.
 - If buzzer is enabled, a short beep will be heard upon pressing the **Menu** button.

In dynamic mode, the simulator automatically adjusts the control step value by itself. This will generate dynamic OBD2 CAN signals. In static mode, all* simulated OBD2 CAN signals will be controlled by the control step value, which is still able to be manually controlled by the **Up** and **Down** buttons.

Note: * The Engine Clock is not controlled by the control step value and push buttons; it runs all by itself just like a real clock.

- Press **Down** button:
 - **Down** button is used to decrease the values of all OBD2 CAN signals. A single press will decrease all data one step from previous values until they reach the minimum values. ▼0% LED will be triggered on/off.
 - If ▼0% LED is on, press **Down** button once, ▼0% LED will be off.
 - If ▼0% LED is off, press **Down** button once, ▼0% LED will be on.
 - 80% LED blinks when control step value equals 80%,
 - 60% LED blinks when control step value equals 60%,
 - 40% LED blinks when control step value equals 40%,
 - 20% LED blinks when control step value equals 20%,

- ▼0% LED blinks when control step equals 0%,
- If buzzer is enabled, a short beep will be heard upon a press on **Down** button.
- Press **Up** button:
 - **Up** button is used to increase the values of all OBD2 CAN signal. A single press will increase all simulated data one step to next data level until they reach the maximum values, ▲100% LED will be triggered on or off.
 - If ▲100% LED is on, press **Up** button once, ▲100% LED will be off.
 - If ▲100% LED is off, press **Up** button once, ▲100% LED will be on.
 - 20% LED blinks when control step value equals 20%,
 - 40% LED blinks when control step value equals 40%,
 - 60% LED blinks when control step value equals 60%,
 - 80% LED blinks when control step value equals 80%,
 - ▲100% LED blinks when control step value equals the highest value, 100%.
 - If buzzer enabled, a short beep will be heard upon a press on **Up** button.
- Press and hold both **Down + Up** button for more than 1 second:
 - **Down + Up** buttons are used to turn buzzer on/off.
 - If buzzer is on, press and hold **Down + Up** for more than 1 second will silent buzzer thereafter.
 - If buzzer is mute, press and hold **Down + Up** for more than 1 second will enable the buzzer thereafter.
 - Both ▲100% and ▼0% LED will flip their on/off status as a visual indication of this dual-button input.
 - If buzzer is enabled, a long beep will be heard to reflect the input of **Down + Up** button.
- Press and hold both **Menu + Down** button for more than 1 second:
 - **Menu + Down** buttons are used to turn Engine DM2 warning on/Reset.
 - Both ▲100% LED and ▼0% LED will flip their status as a visual indication of this dual-button input.
 - If buzzer is enabled, a long beep will be heard to reflect the input of **Menu + Down** button.
 - The Engine DM2 warning messages (on premium and platinum editions) are always on after power-on. It can be reset when an Engine DM3 PGN is received.
 - For continuous test purpose, after an Engine DM3 PGN is received, either re-power-on the simulator or press and hold both **Menu + Down** button for more than 1 second will turn on the Engine DM2 warning again.
- Press and hold both **Menu + Up** button:
 - **Menu + Up** buttons are used to switch between static mode and dynamic mode.
 - Both ▲100% LED and ▼0% LED will flip their status as a visual indication of this dual-button input.
 - If buzzer enabled, a long beep will be heard to reflect the input of **Menu + Up** button.
- Press and hold both **Menu + Up + Down** button for more than 1 second:
 - **Menu + Up + Down** buttons are used to switch CAN bus On/Off.
 - If CAN-OFF is checked, means CAN bus is off, no parameters will be transmitted by the OBD2 CAN Simulator. Three LED (▼0% LED, ▲100% LED, and Range LED) will blink every one second.
 - Both ▲100% LED and ▼0% LED will flip their status as a visual indication of this dual-button input.
 - If buzzer enabled, a long beep will be heard to reflect the input of **Menu + Up + Down** button.

The push button functions are summarized in Table 3-1.

Table 3-1 Summary of Push button functions

Push Button Operation	Function
Press Down button	Decrease all simulated data until they reach the lowest value
Press Up button	Increase all simulated data until they reach the highest value
Press Menu button	DM1 Warning On/Off control (N/A for Value Package and Engine Basic editions)
Press & hold both Down + Up button	Buzzer ON/OFF control
Press & hold Menu + Up button	Switch between Static/Dynamic mode
Press & hold Menu + Down button	Switch On/Off DTC (Engine DTC, Transmission DTC, and ABS)
Press & hold Menu + Up + Down button	Switch On/Off CAN bus

3.4 LED Indicator Status

- When power on, both **Power** LED and **Range** LED is lit, as shown in Figure 3-2.

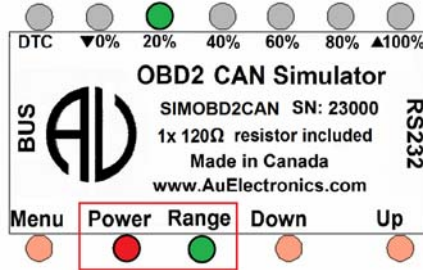

Figure 3-2

All SAE OBD2 CAN data can be changed within the SAE defined range from 0 to 100 control steps (named 0% to 100% control step value from now on), 6 LEDs are used to identify the control step value in the range of 0%, 20%, 40%, 60%, 80%, and 100%.

- ▲ 100% LED will alternate between on or off with a press of the **Up** button, accompanied with the increased brightness of the **Range** LED. A press on the **Up** button will also increase the control step value and all simulated data.
 - When control step value equals 0%, the ▼0% LED blinks.
 - If keep pressing **Up** button, the control step value will keep increasing. The 0% LED will be constantly on, as shown in Figure 3-3. This indicates a data range from 1 - 19%.

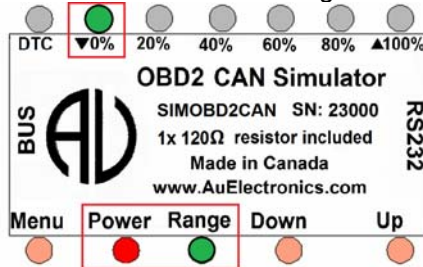

Figure 3-3

- When control step value equals 20%, 20% LED blinks.
 - If keep pressing **Up** button, the control step value will keep increasing. The 20% LED will then be always on, as shown in Figure 3-4. This indicates a data range from 21- 39%.

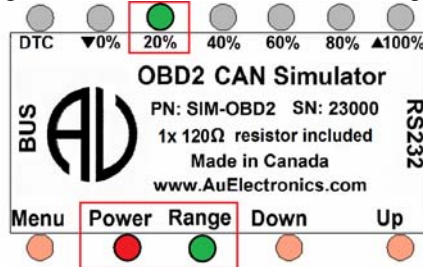

Figure 3-4

- When control step value equals 40%, 40% LED blinks.
 - If keep pressing **Up** button, the control step value will keep rising, 20% and 40% LED will be always on, as shown in Figure 3-5. It indicates the data range from 41% to 59%.

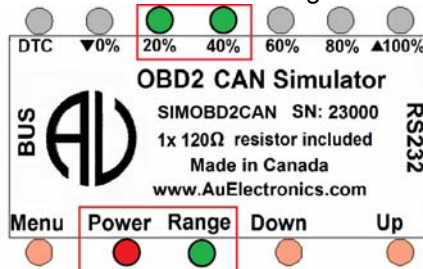

Figure 3-5

- When control step value equals 60%, 60% LED blinks

- If keep pressing **Up** button, the control step value will keep rising, and the 20%, 40%, and 60% LED will be on, as shown in Figure 3-6. It indicates the data range is from 61% to 79%.

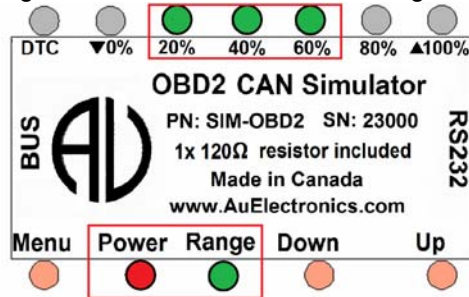

Figure 3-6

- When control step value equals 80%, 80% LED blinks.
- If keep pressing **Up** button, the control step value will keep rising. 20%, 40%, 60%, and 80% LED will be on, as shown in Figure 3-7, it indicates the data range from 81% to 99%.

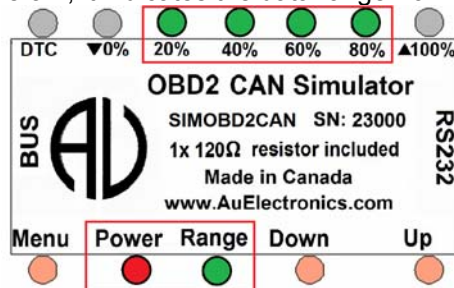

Figure 3-7

- When control step value equals 100%; 20%, 40%, 60%, and 80% LED will be constant on. ▲ 100% LED blinks, as shown in Figure 3-8.

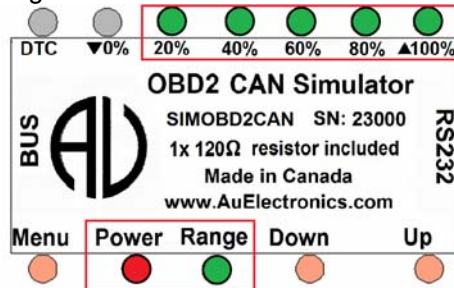

Figure 3-8

- ▼0% LED will alternate between on or off when pressing **Down** button, accompanied with the decreasing brightness of the Range LED. A press on the **Down** button will also decrease the control step value and all simulated data. When the control step value equals 0%, ▼0% LED blinks.
- When CAN bus is off, three LEDs (▼0% LED, ▲100% LED, and Range LED) blinks, as shown in Figure 3-9.

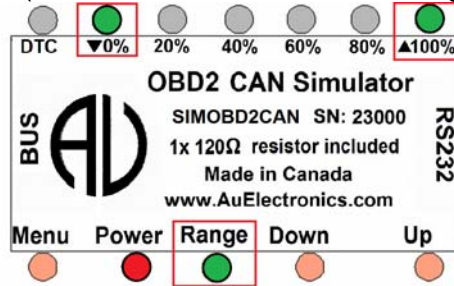

Figure 3-9

Note: Red LEDs and Green LEDs are used in this document for illustration purpose; actual product may have different LED color. Same applies to the push buttons. Au Group Electronics reserve the right of changing the color on each LEDs and push buttons without further notification.

The control step value LED indicator status is summarized in Table 3-2.

Table 3 - 2 Control step value vs. LED indicator status (in Static Mode)

Step	Operation	LED Status
1	Connect +12~+14.2 V DC power supply	Power, Range LED on, the remaining LEDs will recall the last saved status in Static mode
2	Press Down button	▼0% LED on/off
3	Continue press Down button until the control step = 0%	▼0% LED blink
4	Press Up button	▲100% LED on/off
5	Continue press Up button for control step from 1 to 19%	Power, Range LED constant on
6	Continue press Up button for control step = 20%	Power, Range LED on, 20% LED Blink
7	Continue press Up button for control step from 21 to 39%	Power, Range LED on, 20% LED on
8	Continue press Up button for control step = 40%	Power, Range, 20% LED ON, 40% LED Blink
9	Continue press Up button for control step from 41 to 59%	Power, Range, 20%, 40% LED on
10	Continue press Up button for control step = 60%	Power, Range, 20%, 40% LED on, 60% LED blink
11	Continue press Up button for control step from 61 to 79%	Power, Range, 20%, 40%, 60% LED on
12	Continue press Up button for control step = 80%	Power, Range, 20%,40%, 60% LED on, 80% LED blink
13	Continue press Up button for control step from 81 to 99%	Power, Range, 20%, 40%, 60%, 80% LED on
14	Continue press Up button for control step = 100%	Power, Range, 20%, 40%, 60%, 80% LED on, ▲100% blink
15	Press & hold Menu + Up + Down to switch CAN bus on/off	▼0%, ▲100%, and Range LED blink

Chapter - 4 Au OBD2 CAN Simulator Remote Terminal GUI

The Remote Terminal Graphic User Interface (GUI) includes a control panel and a data display area. The control panel is located on the top left portion, the remaining area is for displaying data for “Plus” editions and “Script” editions of Au OBD2 CAN Simulator. It displays engine, ABS, Transmission information, DTC etc.

Figure 4-1 shows the Remote Terminal GUI for Au OBD2 CAN Simulator vehicle platinum script edition. All features are active.

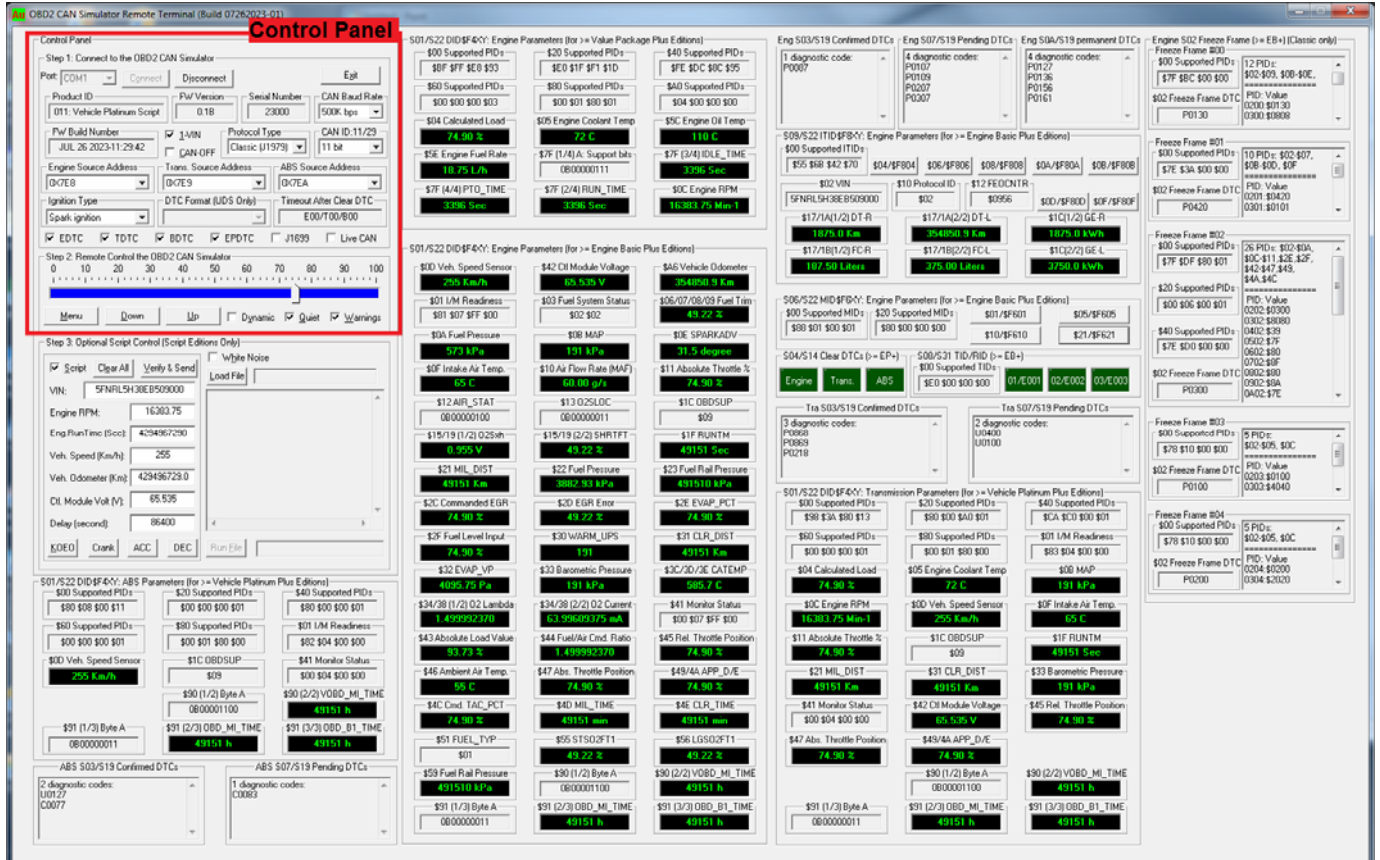
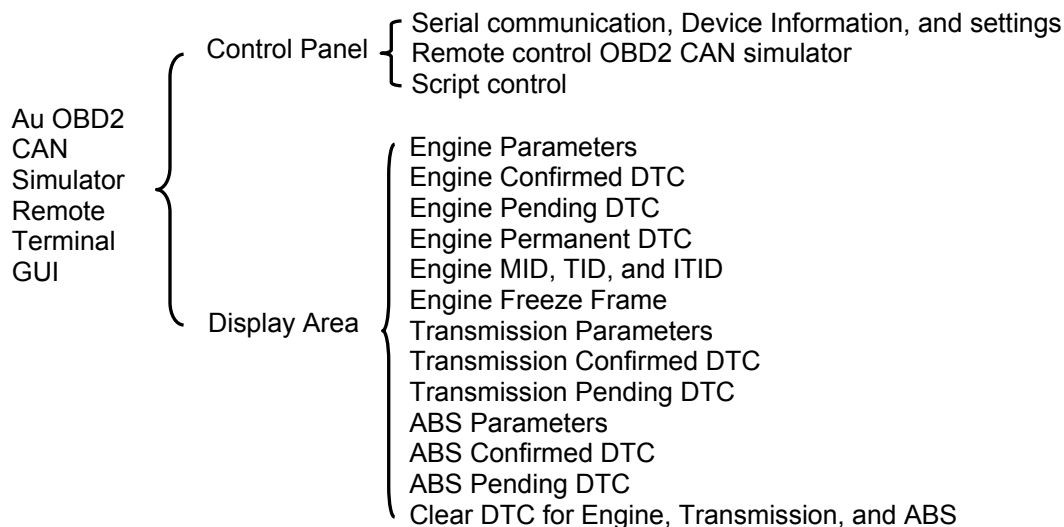

Figure 4-1

Au OBD2 CAN Simulator Remote Terminal structure is summarized below:



The following paragraphs will explain Au OBD2 CAN Simulator remote terminal GUI in detail.

4.1 Control Panel – Step 1: Connect to OBD2 CAN Simulator

Typical connection of Au OBD2 CAN Simulator in an OBD2 CAN network is illustrated in Chapter 1, Figure 1-2.

- Connect the simulator to power supply and OBD2 CAN network, and then connect it to a PC serial port.
- Select correct serial port from the “Port” drop down list, then click the “Connect” button.

Product information and settings of the connected OBD2 CAN Simulator will show up. All the settings will recall the last saved status, as shown in Figure 4 - 2.

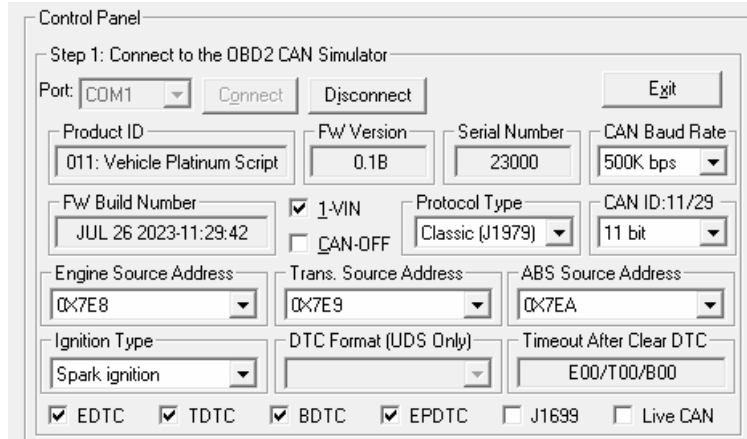

Figure 4-2

Note: Control panel for product information and settings is available for all editions of Au OBD2 CAN Simulator (including non-plus, plus, and script editions).

4.1.1. Device Information

The product information and settings are summarized in Table 4-1

Table 4-1 Au OBD2 CAN Simulator product information and settings

Items	Function
Port	Serial port can be selected from drop down list (COM1 to COM16)
Connect	Click “Connect” to connect OBD2 CAN Simulator with selected PC serial port.
Disconnect	Click “Disconnect” to release the selected serial port.
Exit	Click “Exit” to close the OBD2 CAN Simulator remote terminal GUI
Product ID	Display the part# and edition of OBD2 CAN Simulator (011: Vehicle Platinum Script)
FW Version	Display the FW version of OBD2 CAN Simulator (0.1B)
Serial Number	Display the serial number of OBD2 CAN Simulator (23000)
FW Build Number	Display the firmware build number. (APR 22 2023-14:15:36)
1-VIN	If checked, VIN will be a fixed VIN; If unchecked, VIN changes as control step changes.
CAN-OFF	If checked, CAN bus will be turned off. <i>Script command "AT CANBUS=0"</i>
	If unchecked, CAN bus will be turned on. <i>Script command "AT CANBUS=1"</i>
EDTC	Engine DTC on/off control (for Engine Premium editions and above)
TDTC	Transmission DTC on/off control (for Engine Premium editions and above)
BDTC	Brake DTC on/off control (for Engine Premium editions and above)
EPDTC	Engine Permanent DTC on/off control (for Engine Premium editions and above)
J1699	SAE J1699 test mode on/off control (for Engine Premium script editions and above)
Live CAN	Live CAN mode on/off control
Engine, Transmission, ABS Source Address	Source address at 0x7E8, 0x7E9, 0x7EA, 0x7EB, 0x7EC, 0x7ED, 0x7EE, 0x7EF are available to choose from. Each ECU shall use a unique SA.

If the module is not quiet. Any change on the device setting will trigger a beep to indicate a change.

If there is conflict of source address (SA) detected, an error message will show up.

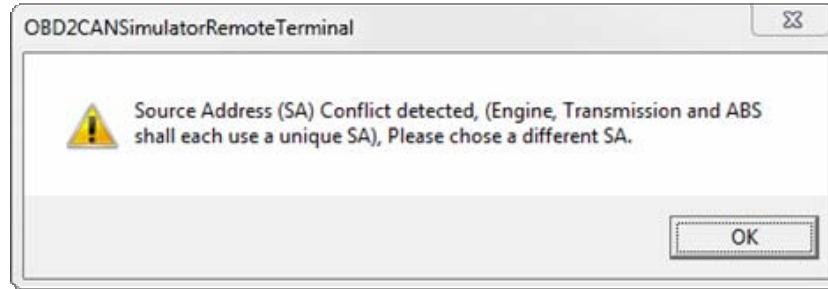

Figure 4-3

4.1.2. Device Settings

- EDTC, TDTC, BDTC, EPDTC, and J1699 are not applicable for Value Package and Engine Basic edition(s).
- EDTC, TDTC, and BDTC will be affected by control the "**Warning**" status (see 4.2 for detail information).

Table 4-2 Serial commands to change or inquire check boxes status

Item	Checked	Unchecked	Inquiry Command	Response
EDTC	Engine DTC is On (AT EDTC=1\r\n)	Engine DTC is Off (AT EDTC=0\r\n)	AT EDTC=?\r\n	ACK EDTC=0/1
TDTC	Transmission DTC is On (AT TDTC=1\r\n)	Transmission DTC is Off (AT TDTC=0\r\n)	AT TDTC=?\r\n	ACK TDTC=0/1
BDTC	Brake DTC is On (AT BDTC=1\r\n)	Brake DTC is Off (AT BDTC=0\r\n)	AT BDTC=?\r\n	ACK BDTC=0/1
EPDTC	Engine Permanent DTC is On (AT ES0A_DTC=0\r\n)	Engine Permanent DTC is Off (AT ES0A_DTC=1\r\n)	AT ES0A_DTC=?\r\n	AT ES0A_DTC=0/1
J1699	SAE J1699 test mode is on (AT J1699=0\r\n)	SAE J1699 test mode is off (AT J1699=1\r\n)	AT J1699=?\r\n	ACK J1699=0/1
Live CAN	Live CAN mode is On (AT LIVECAN=1\r\n)	Live CAN mode is Off (AT LIVECAN=0\r\n)	AT LIVECAN=?\r\n	ACK LIVECAN=0/1

- There are two CAN baud rate to choose from, default CAN baud rate for Au OBD2 CAN simulator is 250K bps.

Table 4 – 3 Other Au OBD2 CAN Simulator Settings

Item	Setting Options	Command	Function
CAN Baud Rate	250K bps	AT CBRS=00\r\n	Switch device CAN baud rate to 250Kbps
	500K bps	AT CBRS=03\r\n	Switch device CAN baud rate to 500Kbps (default)
Protocol Type	OBDonUDS	AT CLASSIC=0\r\n	Switch to OBD on UDS (Unified Diagnostic Services) per SAE J1979-2 / ISO27145 protocol
	Classic	AT CLASSIC=1\r\n	Switch to Classic OBD per SAE J1979 protocol
CAN ID	29 bit	AT CAN11=0\r\n	Switch device to extended 29-bit CAN Identifier
	11 bit	AT CAN11=1\r\n	Switch device to standard 11-bit CAN Identifier
Ignition Type	Spark ignition	AT IGNITION=0\r\n	Switch device to a Spark Ignition vehicle
	Compression ignition	AT IGNITION=1\r\n	Switch device to a Compression Ignition vehicle
DTC format (OBDonUDS*)	J1939-73	AT DTCF=0\r\n	SAE J1939-73 DTC Format (value 4)
	J2012DA	AT DTCF=1\r\n	SAE J2012DA DTC Format (value 2)

- * There are two DTC Format allowed in SAE J1979-2 (OBDonUDS). DTC format option is only available when Protocol type OBDonUDS is selected. It is not applicable for classic OBD.

4.2 Control Panel – Step 2: Remote control Au OBD2 CAN Simulator

Remote control includes 1 scale bar, 3 push buttons (**Menu**, **Down**, **Up**), and 3 check boxes (**Dynamic**, **Quite**, **Warnings**), as shown in **Error! Reference source not found.** These tools are able to remote control the output/simulated signal of the Au OBD2 CAN Simulator **Plus** editions and **Script** editions from a PC.

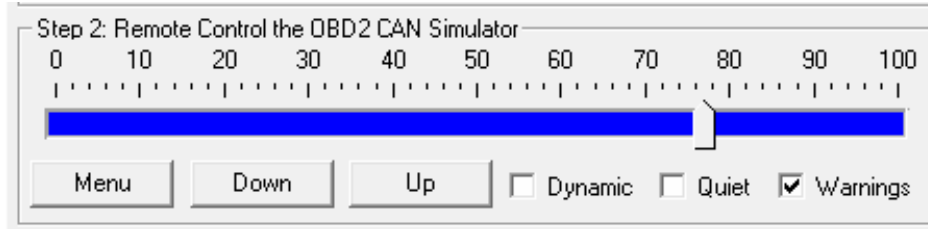

Figure 4-4

The scale bar represents the control step values from 0 to 100. The sliding action can be made by 4 methods: keyboard, mouse, Down/Up buttons from remote terminal, and the Down/Up push button on the device. They are summarized in Table 4-4

Table 4-4 Control Methods for Slide Bar

	Action	Function
Mouse	Left Click	Left click bring the slide to the desired location
	Drag	Click and hold left button to drag the slide to the desired location
Keyboard	▲ or ►	Increase the scale range in 1 interval
	▼ or ◀	Decrease the scale range by 1 interval
	Pg Up	Increase the scale range by 10 interval
	Pg Dn	Decrease the scale range by 10 interval
	home	Move control step value to 0
	end	Move control step value to 100
Remote terminal / Device	Down button	Decrease the scale range by 1 interval
	Up button	Increase the scale range by 1 interval

The function for the 3 push buttons and 3 check boxes is listed in Table 4-5.

Table 4 – 5 Functions for push button and check boxes in step 2

Tool	Function	
Button	Menu	Turn on/off warning (see note below)
	Down	Decrease the control step value by 1
	Up	Increase the control step value by 1
Check box	Dynamic	Switch between dynamic mode / static mode
	Quiet	Turn on/off buzzer
	Warnings	Turn on/off EDTC, TDTC, and BDTC

Note: The "Warnings" Check box and the "Menu" push button are not applicable in Value Package edition(s) and Engine Basic edition(s). They are active only in the **Engine Premium Plus / Script** edition and **Vehicle Platinum Plus / Script** edition.

Warnings On/Off status will change the EDTC, TDTC, and BDTC status and vice versa:

- When "Warnings" is on, all EDTC, TDTC, and BDTC will be on.
- When "Warnings" is off, all EDTC, TDTC, and BDTC will be off.
- When all EDTC, TDTC, and BDTC are on, "Warnings" will be on
- When all EDTC, TDTC, and BDTC are off, "Warning" will be off

4.3 Control Panel – Step 3: Script control

Script control capabilities are available for 3 script editions only: Engine Basic Script Edition, Engine Premium Script Edition, and Vehicle Platinum Script Edition.

Script control sets the following six parameters to any value in the SAE-J1979 or SAE J1979-2 specification allowed range: Vehicle Identification Number (VIN), Engine RPM, Engine Run Time, Vehicle Speed, Vehicle Odometer, and Control Module Voltage.

The range of the input value for each parameter is listed in Table 4 – 6. The inputs will be verified and sent when "Verify & Send" is clicked. If you do not wish to change a particular parameter, just leave the input area empty.

Table 4 – 6 Input values of script controlled parameters

Script Controlled Parameters	Min. Input Value	Max. Input Value
VIN	VIN must consist of 17 characters	
Engine RPM	0	16383.75
Engine Run Time (Sec.)	0	4294967290
Vehicle Speed (km/h)	0	255
Vehicle Odometer (km)	0	429496729.0
Control Module Voltage (volts)	0	65.535
Delay (seconds) *	1	86400 (24 hours)

- Delay is the time that specifies how many seconds to wait before running another script command. If delay time is not set, all script commands will run once and then remain at those values except for Engine Hour and Vehicle Odometer.
- Engine Run Time can be set with an initial value, then it will accumulate over time.
- Vehicle Odometer can be set with an initial value, it will accumulate base on vehicle speed and runtime.

4.3.1 Turn on Script control

- When Script control is available, it can be switched on/off.
- When script control is not available or is turned off, all supported OBD2 CAN parameters are controlled by the step value;
- When script control is turned on, six OBD2 CAN parameters will be controlled by the input value of script control, all the other OBD2 CAN parameters will still be controlled by step value.

Table 4-7 Different conditions of Script Control

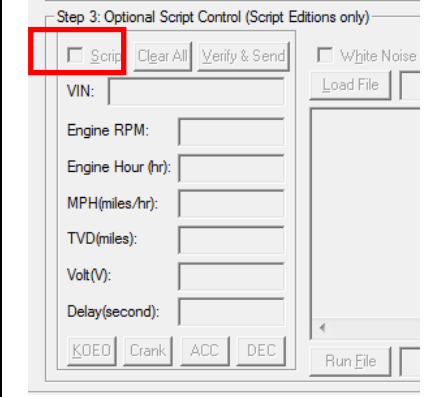
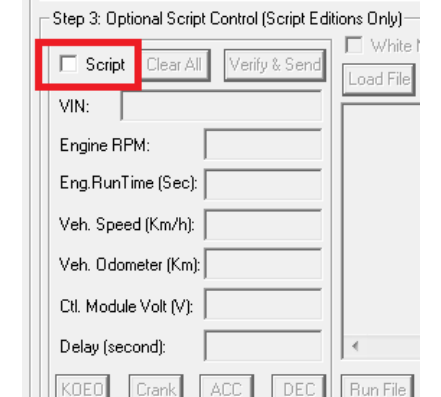
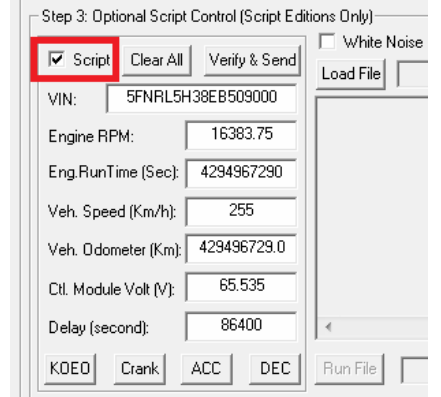
Script control is not available	Script control is turned off	Script control is turned on
 <p>All parameters controlled by step control</p>	 <p>All parameters controlled by step control</p>	 <p>6 parameters controlled by Script control inputs.</p>

4.3.2 Generate Script Command

- When script control is enabled, 6 parameters will be controlled by script control, the maximum allowed values will be showing in its input area respectively.
- Click "Clear All" to clear all values in the input area. It has no effect on the simulator.
- Change the inputs to your desired value.
- Click "Verify & Send". Script command will be sent to OBD2 CAN Simulator, script commands will show in the script viewport.
- Script commands can be copied into any text editor such as Notepad, and used as a segment of a script file (text document with extension*.txt), which can be saved and run at a later time.

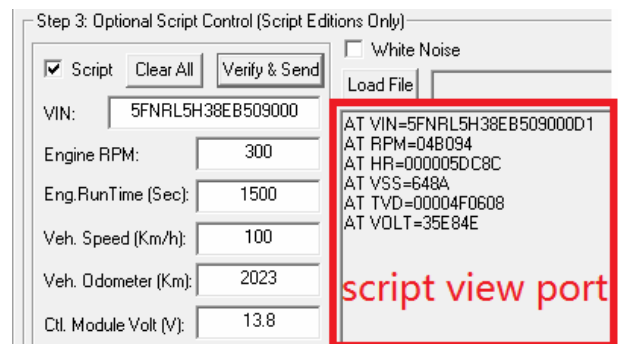

Figure 4 – 5

4.3.3 Script Syntax

The Script syntax for Au OBD2 CAN Simulator is simple, as summarized in Table 4 – 8.

Table 4 - 8 Script Syntax for Au OBD2 CAN Simulator

Keyword	Script command Syntax and Format	Example
<code>\r\n</code>	Each line ends with <code>\r\n</code>	
<code>;</code>	Line comments are preceded by a semicolon (<code>;</code>)	<code>;Cranking Profile</code>
CANBUS	CAN bus on/off control. 0: CAN bus is off, 1: CAN bus is on	<code>AT CANBUS=0</code> <code>AT CANBUS=1</code>
WHITENOISE	White noise on/off control. 0: white noise is off, 1: white noise is on	<code>AT WHITENOISE=0</code> <code>AT WHITENOISE=1</code>
RPM	<code>AT RPM=aabbefn\r\n</code> - script command to set Engine Speed	<code>AT RPM=04B094</code>
VSS	<code>AT VSS=aaef\r\n</code> - script command to set Vehicle Speed	<code>AT VSS=648A</code>
VOLT	<code>AT VOLT=aabbef\r\n</code> - script command to set Control module voltage	<code>AT VOLT=35E84E</code>
TVD	<code>AT TVD=aabbccdef\r\n</code> - command to set Total vehicle Distance	<code>AT TVD=00004F0608</code>
HR	<code>AT HR=aabbccdef\r\n</code> - script command to set Engine Hour	<code>AT HR=000005DC8C</code>
VIN	<code>AT VIN=abcd...</code> - script command to set VIN (17 characters)	<code>AT VIN=5FNRL5H38EB509000D1</code>
DELAY	<code>DELAY(t)</code> -- The last status will stay unchanged for t seconds	<code>DELAY(5)</code>
REPEAT	<code>REPEAT(n){ ... }</code> Script enclosed between a pair of bracelets will repeat for n times. Repeat feature can be nested up to 10 levels	<code>REPEAT(3){</code> <code> REPEAT(5) {</code> <code> </code> <code> }</code> <code>}</code>

Note: Always use the script commands generated by Au OBD2 CAN Simulator Script generator, as any other script may not work properly. For example, the script generated from Au J1708 Simulator will not work for Au OBD2 CAN Simulator and vice versa.

4.3.4 Example of script command segments

To help forming script file, Script control also provides 4 buttons that generate the 4 most commonly used script command segments. These segments can be copied and modified, then saved as a script file with extension of *.txt.

Table 4 – 9 Script Command Segments

KOEO (Key On Engine Off)	Crank	ACC (VSS accelerating)	DCC (VSS decelerating)
<pre> ===== ;Turn off CAN bus ;AT CANBUS=0 ===== ;Turn on CAN bus ;AT CANBUS=1 ===== ;Turn on White Noise ;AT WHITENOISE=1 ===== ;Turn off White Noise ;AT WHITENOISE=0 ===== ;Repeat block function for 5 times REPEAT(5){ } ===== ;Key On Engine Off. RPM=0; </pre>	<pre> ===== ;Cranking Profile ===== ;VSS=0 AT VSS=002B ===== ;RPM=0, Volt=12.6V, delay 1s, AT RPM=0000F5 AT VOLT=3138AF DELAY(1) ===== ;RPM=400, Volt=11.4V, delay 1s, AT RPM=064055 AT VOLT=2C884E DELAY(1) ===== ;RPM=800, Volt=4.2V, delay 1s, AT RPM=0C8044 AT VOLT=1068AF </pre>	<pre> ===== ;Accelerate Profile ===== ;RPM=650, VSS=0, delay 1s, AT RPM=0A2844 AT VSS=002B DELAY(1) ===== ;RPM=880, VSS=8, delay 1s, AT RPM=0DC083 AT VSS=08AA DELAY(1) ===== ;RPM=1110, VSS=16, delay 1s, AT RPM=115805 AT VSS=101B DELAY(1) ===== ;RPM=1340, VSS=24, delay 1s, </pre>	<pre> ===== ;Decelerate Profile ===== ;RPM=2500, VSS=65, delay 1s, AT RPM=271055 AT VSS=41DA DELAY(1) ===== ;RPM=2260, VSS=56, delay 1s, AT RPM=235055 AT VSS=387A DELAY(1) ===== ;RPM=2030, VSS=48, delay 1s, AT RPM=1FB8E2 AT VSS=30FA DELAY(1) ===== ;RPM=1800, VSS=40, delay 1s, </pre>

<pre>VSS=0; Volt=12.6V; ===== AT RPM=0000F5 AT VSS=002B AT VOLT=3138AF =====</pre>	<pre>DELAY(1) ===== ;RPM=1200, Volt=13.8V, delay 1s, AT RPM=12C094 AT VOLT=35E84E DELAY(1) ===== ;RPM=650, Volt=14.2V, delay 1s, AT RPM=0A2844 AT VOLT=37780F DELAY(1) =====</pre>	<pre>AT RPM=14F044 AT VSS=189A DELAY(1) ===== ;RPM=1570, VSS=32, delay 1s, AT RPM=188864 AT VSS=200B DELAY(1) ===== ;RPM=1800, VSS=40, delay 1s, AT RPM=1C2094 AT VSS=288A DELAY(1) ===== ;RPM=2030, VSS=48, delay 1s, AT RPM=1FB8E2 AT VSS=30FA DELAY(1) ===== ;RPM=2260, VSS=56, delay 1s, AT RPM=235055 AT VSS=387A DELAY(1) ===== ;RPM=2500, VSS=65, delay 1s, AT RPM=271055 AT VSS=41DA DELAY(1) =====</pre>	<pre>AT RPM=1C2094 AT VSS=288A DELAY(1) ===== ;RPM=1570, VSS=32, delay 1s, AT RPM=188864 AT VSS=200B DELAY(1) ===== ;RPM=1340, VSS=24, delay 1s, AT RPM=14F044 AT VSS=189A DELAY(1) ===== ;RPM=1110, VSS=16, delay 1s, AT RPM=115805 AT VSS=101B DELAY(1) ===== ;RPM=880, VSS=8, delay 1s, AT RPM=0DC083 AT VSS=08AA DELAY(1) ===== ;RPM=650, VSS=0, delay 1s, AT RPM=0A2844 AT VSS=002B DELAY(1) =====</pre>
--	--	---	---

4.3.5 Run script from a file

- Click "Load File" to load a script file

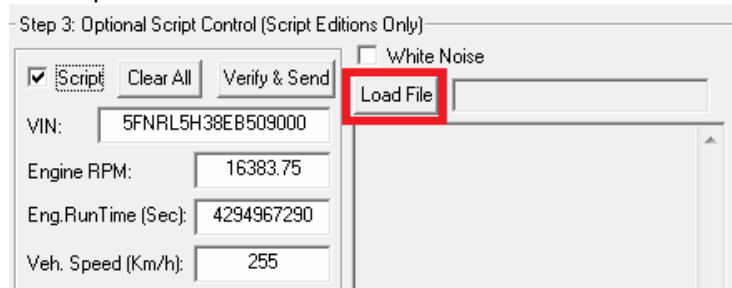

Figure 4 - 6

- Select the desired script file, then click "Open"

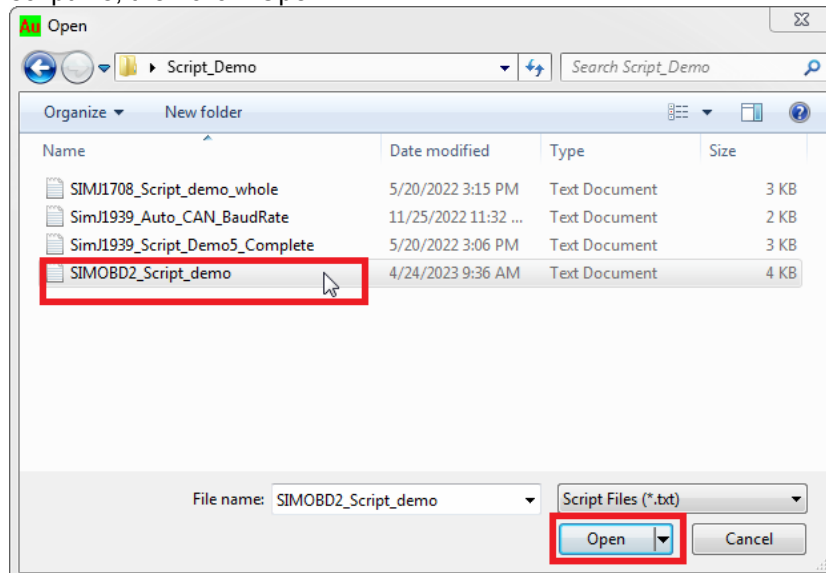

Figure 4 - 7

- Loaded script file name will display at the top right.
- In the script view port, script name and all script commands in the script file will display. Use the scroll bar on the right-hand side to view more script commands.
- Click "Run File" button to run script file.
- Current running script command will be highlighted in the script view port.
- Script running status will be shown at the bottom status area (for example, current command is delay, delay counting down timer is shown)

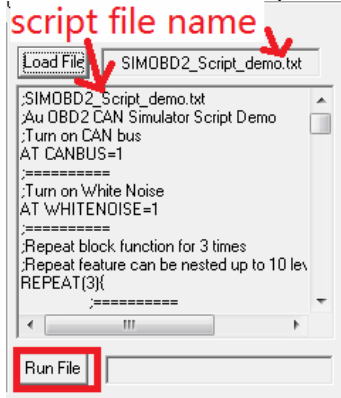

Figure 4-8

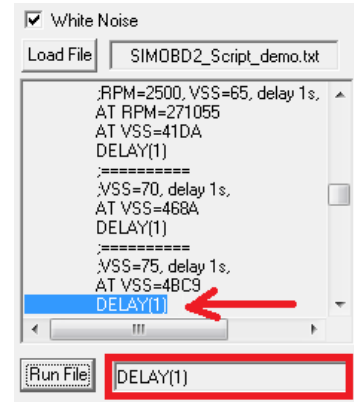

Figure 4-9

- When finish running, last command of the script file will be highlighted.
- "Script Finished Successfully" message will be shown as the running status

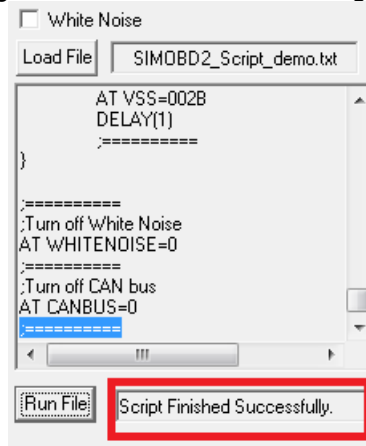

Figure 4-10

4.4 Display Panel

4.4.1. Value Package Parameters

Au OBD2 CAN Simulator Value Package Plus edition displays the following 13 engine parameters for service \$01 or \$22 DID F401, as shown in figure 4-11

- Supported PIDs between \$00 and \$80
- Calculated LOAD Value
- Engine Coolant Temperature
- Engine RPM
- Engine Oil Temperature
- Engine Fuel Rate
- Support of Engine Run Time (1/4)
- Total Engine Run Time (2/4)
- Total Idle Run Time (3/4)
- Total Run Time With PTO Active (4/4)

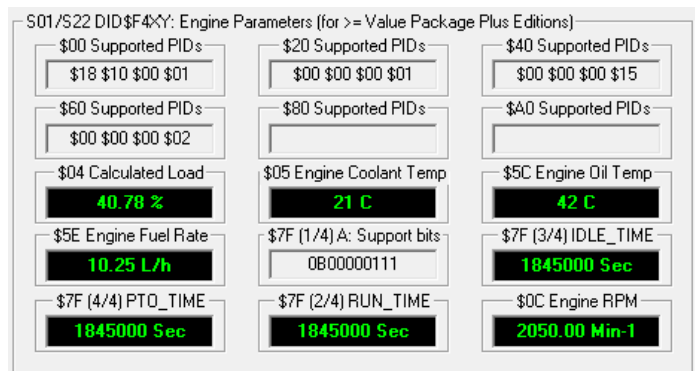

Figure 4-11

4.4.2. Engine Basic Parameters

Au OBD2 CAN Simulator Engine Basic plus edition displays 66 engine parameters for service \$01 / \$22, as shown in Figure 4-12

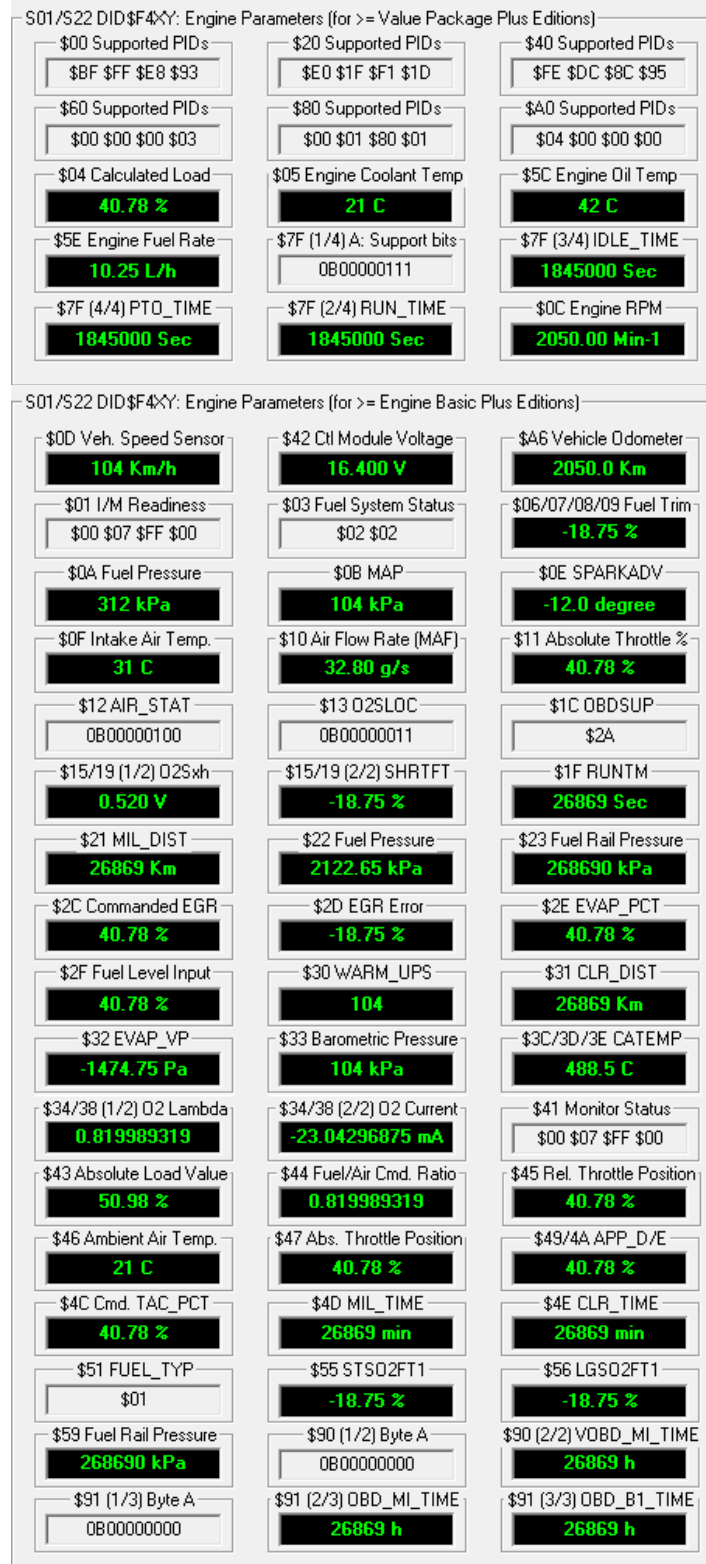

Figure 4 – 12

PID \$7F / \$F47F have 4 data bytes, byte A indicates all three total run time are supported: Total Engine run time, total idle run time, and total run time with PTO active. Those simulation data are displayed in each respective area.

Table 4 – 10 PID \$7F / \$F47F Byte A: support bits and other data

PID \$7F / \$F47F (Engine Run Time – Byte A: Support bits)				
Byte A	A, bit 7-3	A, bit 2	A, bit 1	A, bit 0
0B00000111 \$7F (1/4) A: Support bits 0B00000111	Reserved, 0	Total Run Time With PTO Active supported \$7F (4/4) PTO_TIME 3375000 Sec	Total Idle Run Time supported \$7F (3/4) IDLE_TIME 3375000 Sec	Total Engine Run Time supported \$7F (2/4) RUN_TIME 3375000 Sec

- For Classic OBD, Au OBD2 CAN simulator Engine Basic editions support freeze frame #00
- For OBDOnUDS, Au OBD2 CAN simulator Engine Basic editions have no freeze frame data

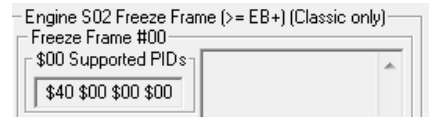

Figure 4 – 13

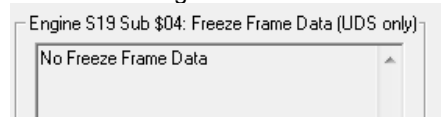

Figure 4 – 14

- Au OBD2 CAN simulator Engine Basic edition have zero confirmed DTC, zero Pending DTC, and zero permanent DTC.

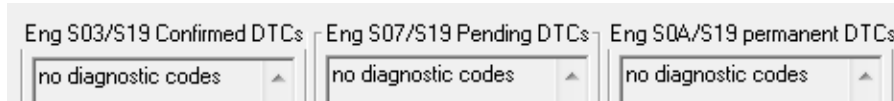

Figure 4 – 15

Request On-Board Monitoring Test Results for Specific Monitored Systems Using Service \$06 /\$22 – MID

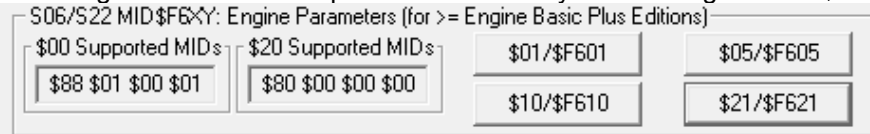

Figure 4 – 16

Table 4 – 11 Supported MID for Service \$06 /Service \$22

MID # Classic / OBDOnUDS	Monitor ID (MID) Description	Simplified Raw Data
MID \$00/ \$F600	Supported PIDs	\$88 \$01 \$00 \$01
MID \$20/ \$F620	Supported PIDs	\$80 \$00 \$00 \$00
MID \$01/ \$F601	Exhaust Gas Sensor Monitor Bank 1 - Sensor 1	<-01 01 0A 0B B0 0B B0 0B B0 <-01 05 10 00 48 00 00 00 64 <-01 85 24 00 96 00 4B FF FF
MID \$05/ \$F605	Exhaust Gas Sensor Monitor Bank 2 - Sensor 1	<-05 01 0A 0B B0 0B B0 0B B0 <-05 05 10 00 48 00 00 00 64 <-05 85 24 00 96 00 4B FF FF
MID \$10/ F610	Exhaust Gas Sensor Monitor Bank 4 - Sensor 4	<-10 01 0A 0B B0 0B B0 0B B0 <-10 05 10 00 48 00 00 00 64 <-10 85 24 00 96 00 4B FF FF
MID \$21/ \$F621	Catalyst Monitor Bank 1	<-21 87 2E 00 00 00 00 00 00

Upon receiving the Request Control of On-Board System, Test, or Component through Service \$08 or Service \$31, Au ODB2 Simulator Engine Basic Plus and above edition will beep, and the corresponding LED light on the GUI will flash once.

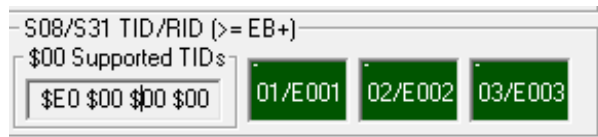

Figure 4 – 17

Table 4 – 12 Supported TID for Service \$08 / Service \$31

TID #	Test ID (TID) Description	Simulator Data
TID \$00/\$E000	Supported TIDs	\$E0 \$00 \$00 \$00
TID \$01/\$E001	Evaporative system leak test	LED 01/E001 will flash once 01/E001 02/E002 03/E003
TID \$02/\$E002	Particulate Filter Regeneration	LED 02/E002 will flash once 01/E001 02/E002 03/E003
TID \$03/\$E003	Inducement System Re-initialization	LED 03/E003 will flash once 01/E001 02/E002 03/E003

Request Vehicle Information using Service \$09 /Service \$22 - ITID

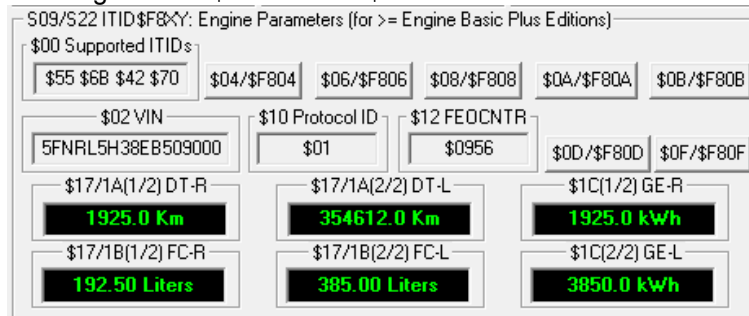

Figure 4 – 18

Table 4 – 13 Supported ITID for Service \$09 /Service \$22

ITID #	Info-Type ID (ITID) Description	Simulator Data
ITID \$00/\$F800	Supported ITID	\$55 \$6B \$42 \$70
ITID \$02/\$F802	Vehicle Identification Number (VIN)	5FNRL5H31EB509078
ITID \$04/\$F804	Calibration Identifications (CALID)	Cal. ID#1=[JMB*36761500] Cal. ID#2=[JMB*4787261111]
ITID \$06/\$F806	Calibration Verification Numbers(CVN)	CVN#1 = [17 91 BC 82] CVN#2 = [16 E0 62 BE]
ITID \$08/\$F808	In-use Performance Tracking for spark ignition engines	56 Data bytes
ITID \$0A/\$F80A	ECUNAME	ECU Name = [ECM1"CEngineControl]
ITID \$0B/\$F80B	In-use Performance Tracking for compression ignition engines	36 Data bytes
ITID \$0D/\$F80D	Engine Serial Number (ESN)	ESN = [CMMNS 3217486]
ITID \$0F/\$F80F	Exhaust Regulation Or Type Approval Number (EROTAN)	EROTAN = [DOC-CR-934567]
ITID \$10/\$F810	Protocol Identification	Classic OBD: Protocol ID = \$02 OBDOnUDS: Protocol ID = \$01
ITID \$12/\$F812	Fueled Engine Operation Ignition Cycle Counter	\$0956 → 2390 cnts
ITID \$17/\$F817	Vehicle Operation Data - Distance/Fuel Used:	16 Data bytes
ITID \$1A/\$F81A	Plug-in Hybrid Vehicle Distance Data	24 Data bytes
ITID \$1B/\$F81B	Plug-in Hybrid Vehicle Fuel Data	16 Data bytes
ITID \$1C/\$F81C	Plug-in Hybrid Vehicle Grid Data	24 Data bytes

4.4.3. Engine Premium Parameters

Au OBD2 CAN simulator Engine Premium editions have all functions provided by Engine Basic editions, it also supports confirmed DTC, Pending DTC, permanent DTC, and Freeze frames. See detailed support list in Chapter 2.

4.4.3.1. Confirmed DTC, Pending DTC, and Permanent DTC

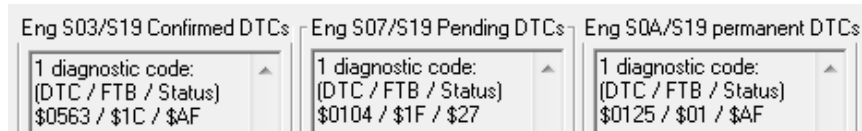

Figure 4 – 19

4.4.3.2. Engine Freeze Frames for Classic OBD

Au OBD2 CAN simulator Engine Premium plus and above editions provide 5 freeze frames for classic OBD. The GUI shows the supported PID (\$00) for each freeze frame, freeze frame DTC (\$02), and detail information for each PID (PID and PID value).

Table 4 – 14 5 Freeze Frames GUI for Classic OBD

Freeze Frame #00	Freeze Frame #02	Freeze Frame #03
<p>Freeze Frame #00</p> <p>\$00 Supported PIDs: \$7F \$BC \$00 \$00</p> <p>\$02 Freeze Frame DTC: P0130</p> <p>12 PIDs: \$02-\$09, \$0B-\$0E, \$0A, \$0C, \$0D, \$0F</p> <p>PID: Value 0200:\$0130 0300:\$0808</p>	<p>Freeze Frame #02</p> <p>\$00 Supported PIDs: \$7F \$DF \$80 \$01</p> <p>\$20 Supported PIDs: \$00 \$06 \$00 \$01</p> <p>\$40 Supported PIDs: \$7E \$D0 \$00 \$00</p> <p>\$02 Freeze Frame DTC: P0300</p> <p>26 PIDs: \$02-\$0A, \$0C-\$11, \$2E, \$2F, \$42-\$47, \$49, \$4A, \$4C</p> <p>PID: Value 0202:\$0300 0302:\$8080 0402:\$39 0502:\$7F 0602:\$80 0702:\$8F 0802:\$80 0902:\$8A 0A02:\$7E</p>	<p>Freeze Frame #03</p> <p>\$00 Supported PIDs: \$78 \$10 \$00 \$00</p> <p>\$02 Freeze Frame DTC: P0100</p> <p>5 PIDs: \$02-\$05, \$0C</p> <p>PID: Value 0203:\$0100 0303:\$4040</p>
Freeze Frame #01	Freeze Frame #04	Freeze Frame #04
<p>Freeze Frame #01</p> <p>\$00 Supported PIDs: \$7E \$3A \$00 \$00</p> <p>\$02 Freeze Frame DTC: P0420</p> <p>10 PIDs: \$02-\$07, \$0B-\$0D, \$0F</p> <p>PID: Value 0201:\$0420 0301:\$0101</p>	<p>Freeze Frame #04</p> <p>\$00 Supported PIDs: \$78 \$10 \$00 \$00</p> <p>\$02 Freeze Frame DTC: P0200</p> <p>5 PIDs: \$02-\$05, \$0C</p> <p>PID: Value 0204:\$0200 0304:\$2020</p>	

Table 4 – 15 Detail information of 5 Freeze Frames Data for Classic OBD

Freeze Frame	#00	#01	#02	#03	#04	
Supported PIDs	\$7F \$BC \$00 \$00	\$7E \$3A \$00 \$00	\$00 \$06 \$00 \$01 \$7E \$D0 \$00 \$00	\$78 \$10 \$00 \$00	\$78 \$10 \$00 \$00	
Freeze Fr. DTC	P0130	P0420	P0300	P0100	P0200	
PID #	12 PIDs: \$02-\$09, \$0B-\$0E	10 PIDs: \$02-\$07, \$0B-\$0D, \$0F	26 PIDs: \$02-\$0A, \$0C-\$11, \$2E, \$2F, \$42-\$47, \$49, \$4A, \$4C	5 PIDs: \$02-\$05, \$0C	5 PIDs: \$02-\$05, \$0C	
PID: Value	0200: \$0130 0300: \$0808 0400: \$33 0500: \$28 0600: \$94 0700: \$9E 0800: \$8A 0900: \$A3 0B00: \$32 0C00: \$0FA0 0D00: \$0A 0E00: \$62	0201: \$0420 0301: \$0101 0401: \$66 0501: \$97 0601: \$83 0701: \$7C 0B00: \$1B 0C00: \$1FCC 0D00: \$4A 0F00: \$44	0202: \$0300 0302: \$8080 0402: \$39 0502: \$7F 0602: \$80 0702: \$8F 0802: \$80 0902: \$8A 0A02: \$7E 0C02: \$12B8 0D02: \$00 0E02: \$D4 0F02: \$4E	1002: \$0230 1102: \$21 2E02: \$00 2F02: \$6C 4202: \$364C 4302: \$002C 4402: \$C3F4 4502: \$05 4602: \$4A 4702: \$21 4902: \$10 4A02: \$10 4C02: \$07	0203: \$0100 0303: \$4040 0403: \$20 0503: \$5A 0C03: \$1388	0204: \$0200 0304: \$2020 0404: \$66 0504: \$25 0C04: \$1770

4.4.3.3. Engine Freeze Frames and other services \$19 for OBDonUDS

Table 4 – 16 Supported Service \$19 sub \$04, \$06, \$1A, \$56.

Service \$19 Sub \$04	Service \$19 Sub \$1A	Service \$19 Sub \$06	Service \$19 Sub \$56
5 freeze frames for OBDonUDS.	Request Supported DTC Extended Record Information	Request DTC Extended Data Record	Request DTCs for a Readiness Group
<p>Engine S19 Sub \$04: Freeze Frame Data (UDS only)</p> <p>= OBDonUDS Simplified Raw Data =</p> <pre>>(06) 19 04 01 04 1F 00~F0 <(24) 59 04 01 04 1F 27 00~F0 09 <-F4 04 33 <-F4 05 8C <-F4 06 8A <-F4 07 8B <-F4 08 8C <-F4 09 8D <-F4 0A 44 <-F4 0F 50 <-F4 10 07 D0 ===== >(06) 19 04 05 63 1C 00~F0 <(0C) 59 04 05 63 1C AF 00~F0 01 <-F4 42 3B 60 =====</pre>	<p>Engine S19 \$1A Supported DTC Extended Record</p> <p>= OBDonUDS Simplified Raw Data =</p> <pre>>(03) 19 1A 90 <(08) 59 1A FF 90 <-01 96 01 AF ===== >(03) 19 1A 91 <(08) 59 1A FF 91</pre>	<p>Engine S19 \$06 DTC Extended Data Record</p> <p>= OBDonUDS Simplified Raw Data =</p> <pre>>(06) 19 06 01 96 01 90 <(09) 59 06 01 96 01 AF 90 <-30 39 ===== >(06) 19 06 05 62 11 91 <(0B) 59 06 05 62 11 AF 91</pre>	<p>Engine S19 \$56 DTCs for a Readiness Group</p> <p>= OBDonUDS Simplified Raw Data =</p> <pre>>(04) 19 56 33 01 <(0A) 59 56 33 FF <-04 01 <-04 20 00 AF ===== >(04) 19 56 33 02 <(0A) 59 56 33 FF <-04 02 <-04 23 01 AF ===== >(04) 19 56 33 03 <(2A) 59 56 33 FF <-04 03 <-03 00 00 40 03 01 00 40 03 02 00 44 <-03 03 00 40 03 04 00 40 03 05 00 40 <-03 06 00 40 03 07 00 40 03 08 00 40 =====</pre>

4.4.4. Vehicle Platinum Parameters

Au OBD2 CAN simulator Vehicle Platinum editions have all functions provided by Engine premium editions. They also support 2 more ECUs: Transmission and ABS, including many supported PID and diagnostic services for each ECU. See detailed support list in Chapter 2.

4.4.4.1. Transmission Parameters

The GUI for Transmission related parameters are shown in Figure 4-20, Transmission related confirmed DTC are shown in Figure 4 – 21, pending DTC are shown in Figure 4 – 22.

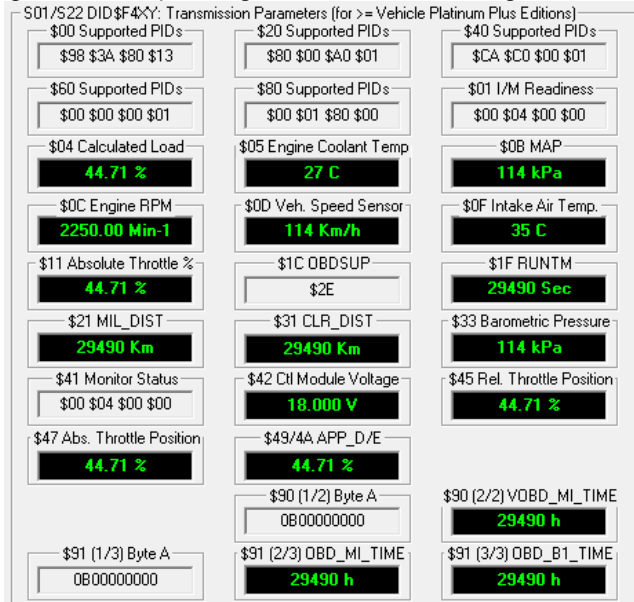

Figure 4 – 20

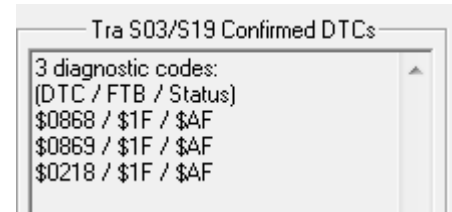

Figure 4 – 21

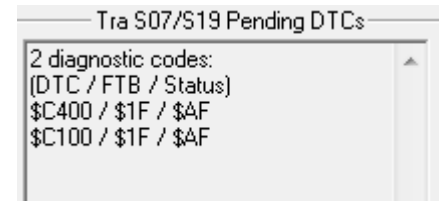

Figure 4 – 22

4.4.4.2. ABS Parameters

The GUI for ABS related parameters are shown in Figure 4-23, ABS related confirmed DTC are shown in Figure 4 – 24, ABS pending DTC are shown in Figure 4 – 25.

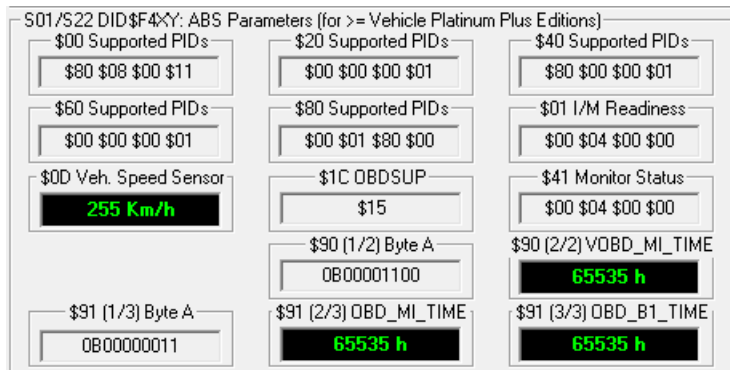

Figure 4 – 23



Figure 4 – 24

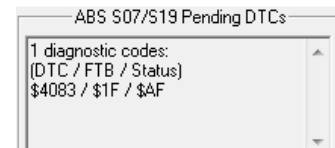

Figure 4 – 25

Chapter - 5 Data Configuration

5.1 Simulation Status at each control step

Au OBD2 CAN Simulator supports up to 3 ECUs: Engine, Transmission, and ABS. Table 5-1 shows supported parameters for each services from each ECU in each segment.

Table 5 – 1

Classic / OBDonUDS	Service \$01 Supported PID			Service \$06	Service \$08	Service \$09
	Engine	Transmission	ABS	Engine	Engine	Engine
PID \$00 / \$F400	\$BF \$FF \$E8 \$93	\$98 \$3A \$80 \$13	\$80 \$08 \$00 \$11	\$88 \$01 \$00 \$01	\$E0 \$00 \$00 \$00	\$55 \$6B \$42 \$70
PID \$20 / \$F420	\$E0 \$1F \$F1 \$1D	\$80 \$00 \$A0 \$01	\$00 \$00 \$00 \$01	\$80 \$00 \$00 \$00	/	/
PID \$40 / \$F440	\$FE \$DC \$8C \$95	\$CA \$C0 \$00 \$01	\$80 \$00 \$00 \$01	/	/	/
PID \$60 / \$F460	\$00 \$00 \$00 \$03	\$00 \$00 \$00 \$01	\$00 \$00 \$00 \$01	/	/	/
PID \$80 / \$F480	\$00 \$01 \$80 \$01	\$00 \$01 \$80 \$00	\$00 \$01 \$80 \$00	/	/	/
PID \$A0 / \$F4A0	\$04 \$00 \$00 \$00	/	/	/	/	/

Table 5 -2 PID\$01/\$F401 Simulated values from each ECU

Step	PID \$01 / \$F401 (I/M Readiness Data)		
	Engine	Transmission	ABS
0 ~ 10	\$00 \$00 \$00 \$00	\$00 \$00 \$00 \$00	\$00 \$00 \$00 \$00
11 ~ 20	\$00 \$77 \$FF \$FF	\$00 \$44 \$00 \$00	\$00 \$44 \$00 \$00
21 ~ 100	\$00 \$07 \$FF \$00	\$00 \$04 \$00 \$00	\$00 \$04 \$00 \$00

Table 5 – 3 PID\$41/\$F441 Simulated values from each ECU

Step	PID \$41 / \$F441 (Monitor status this driving cycle)		
	Engine	Transmission	ABS
0 ~ 10	\$00 \$00 \$00 \$00	\$00 \$00 \$00 \$00	\$00 \$00 \$00 \$00
11 ~ 20	\$00 \$70 \$00 \$FF	\$00 \$40 \$00 \$00	\$00 \$40 \$00 \$00
21 ~ 100	\$00 \$77 \$FF \$FF	\$00 \$04 \$00 \$00	\$00 \$04 \$00 \$00

Table 5 – 4 PID\$03/\$F403, PID\$12/\$F412, and PID\$13/\$F413 simulated values for Service \$01 from Engine

Step	PID \$03 / \$F403 (Fuel system status)	PID \$12 / \$F412 (Commanded Secondary Air Status)	PID \$13 / \$F413 (Location of oxygen sensors)
0	\$00 \$00	0B00000000	0B00000000
1	\$01 \$01	0B00000001	0B00000011
2	\$02 \$02	0B00000010	0B00001111
3	\$04 \$04	0B00000100	0B00110000
4	\$08 \$08	0B00001000	0B00110011
5	\$10 \$10	0B00000100	0B00111111
6	\$20 \$20	0B00000100	0B11110000
7	\$40 \$40	0B00000100	0B11110011
8	\$80 \$80	0B00000100	0B11111111
9 ~ 100	\$02 \$02	0B00000100	0B00000011

Table 5 - 5 shows the simulated values of service \$01 PID\$51/\$F451 for Engine and PID\$1C/F41C for each ECU at different control steps.

Table 5 – 5 Service \$01 PID\$51/\$F451 from Engine and PID\$1C/F41C from each ECU

Step	PID \$51 / \$F451 (Type of fuel currently being utilized by vehicle)	PID \$1C / \$F41C (OBD requirements for vehicle or engine)		
	Engine	Engine	Transmission	ABS
0	\$00	\$01	\$01	\$01
1	\$01	\$02	\$02	\$02
2	\$02	\$03	\$03	\$03
3	\$03	\$04	\$04	\$04
4	\$04	\$05	\$05	\$05
5	\$05	\$06	\$06	\$06
6	\$06	\$07	\$07	\$07
7	\$07	\$08	\$08	\$08
8	\$08	\$09	\$09	\$09
9	\$09	\$0A	\$0A	\$0A
10	\$0A	\$0B	\$0B	\$0B
11	\$0B	\$0C	\$0C	\$0C
12	\$0C	\$0D	\$0D	\$0D
13	\$0D	\$0E	\$0E	\$0E
14	\$0E	\$0F	\$0F	\$0F
15	\$0F	\$10	\$10	\$10
16	\$10	\$11	\$11	\$11
17	\$11	\$12	\$12	\$12
18	\$12	\$13	\$13	\$13
19	\$13	\$14	\$14	\$14
20	\$14	\$15	\$15	\$15
21	\$15	\$16	\$16	\$16
22	\$16	\$17	\$17	\$17
23	\$17	\$18	\$18	\$18
24	\$18	\$19	\$19	\$19
25	\$19	\$1A	\$1A	\$1A
26	\$1A	\$1B	\$1B	\$1B
27	\$1B	\$1C	\$1C	\$1C
28	\$1C	\$1D	\$1D	\$1D
29	\$1D	\$1E	\$1E	\$1E
30	\$1E	\$1F	\$1F	\$1F
31	\$1F	\$20	\$20	\$20
32	\$20	\$21	\$21	\$21
33	\$01	\$22	\$22	\$22
34	\$01	\$23	\$23	\$23
35	\$01	\$24	\$24	\$24
36	\$01	\$25	\$25	\$25
37	\$01	\$26	\$26	\$26
38	\$01	\$27	\$27	\$27
39	\$01	\$28	\$28	\$28
40	\$01	\$29	\$29	\$29
41	\$01	\$2A	\$2A	\$2A
42	\$01	\$2B	\$2B	\$2B
43	\$01	\$2C	\$2C	\$2C
44	\$01	\$2D	\$2D	\$2D
45	\$01	\$2E	\$2E	\$2E
46	\$01	\$2F	\$2F	\$2F
47	\$01	\$30	\$30	\$30
48	\$01	\$31	\$31	\$31
49 - 100	\$01	\$15	\$15	\$15

Table 5 – 6 Simulated values of Service \$01 PID\$90/\$F490 and PID\$91/F491 for each ECU

Step	PID \$90 / \$F490 (Byte A)			PID \$91 / \$F491 Byte A		
	Engine	Transmission	ABS	Engine	Transmission	ABS
0	0B00000000	0B00000000	0B00000000	0B00000000	0B00000000	0B00000000
1	0B00000101	0B00000101	0B00000101	0B00000001	0B00000001	0B00000001
2	0B00001010	0B00001010	0B00001010	0B00000010	0B00000010	0B00000010
3	0B00001111	0B00001111	0B00001111	0B00000011	0B00000011	0B00000011
4	0B00111000	0B00111000	0B00111000	0B00001110	0B00001110	0B00001110
5	0B00111100	0B00111100	0B00111100	0B00001111	0B00001111	0B00001111
6 ~ 100	0B00001100	0B00001100	0B00001100	0B00000011	0B00000011	0B00000011

5.2 Value Package Engine Parameters Simulation values

Table 5 – 7 Service \$01 PID Simulated values from Engine (for Value Package)

Step	\$04 / \$F404	\$05 / \$F405	\$5C / \$F45C	\$5E / \$F45E	\$7F / \$F47F	\$0C / \$F40C
	LOAD_PCT (%)	ECT(C)	EOT C)	FUEL_RATE(L/h))	IDLE_TIME(sec)	RPM(Min-1)
0	0.00%	-40	-40	0.00	0	0.00
1	0.78%	-39	-38	0.25	45000	50.00
2	1.96%	-37	-36	0.50	90000	100.00
3	2.75%	-36	-34	0.75	135000	150.00
4	3.92%	-34	-32	1.00	180000	200.00
5	4.71%	-33	-30	1.25	225000	250.00
6	5.88%	-31	-28	1.50	270000	300.00
7	6.67%	-30	-26	1.75	315000	350.00
8	7.84%	-28	-24	2.00	360000	400.00
9	8.63%	-27	-22	2.25	405000	450.00
10	9.80%	-25	-20	2.50	450000	500.00
11	10.98%	-24	-18	2.75	495000	550.00
12	11.76%	-22	-16	3.00	540000	600.00
13	12.94%	-21	-14	3.25	585000	650.00
14	13.73%	-19	-12	3.50	630000	700.00
15	14.90%	-18	-10	3.75	675000	750.00
16	15.69%	-16	-8	4.00	720000	800.00
17	16.86%	-15	-6	4.25	765000	850.00
18	17.65%	-13	-4	4.50	810000	900.00
19	18.82%	-12	-2	4.75	855000	950.00
20	20.00%	-10	0	5.00	900000	1000.00
21	20.78%	-9	2	5.25	945000	1050.00
22	21.96%	-7	4	5.50	990000	1100.00
23	22.75%	-6	6	5.75	1035000	1150.00
24	23.92%	-4	8	6.00	1080000	1200.00
25	24.71%	-3	10	6.25	1125000	1250.00
26	25.88%	-1	12	6.50	1170000	1300.00
27	26.67%	0	14	6.75	1215000	1350.00
28	27.84%	2	16	7.00	1260000	1400.00
29	28.63%	3	18	7.25	1305000	1450.00
30	29.80%	5	20	7.50	1350000	1500.00
31	30.98%	6	22	7.75	1395000	1550.00
32	31.68%	8	24	8.00	1440000	1600.00
33	32.94%	9	26	8.25	1485000	1650.00
34	33.73%	11	28	8.50	1530000	1700.00
35	34.90%	12	30	8.75	1575000	1750.00
36	35.69%	14	32	9.00	1620000	1800.00
37	36.86%	15	34	9.25	1665000	1850.00
38	37.65%	17	36	9.50	1710000	1900.00
39	38.82%	18	38	9.75	1755000	1950.00

40	40.00%	20	40	10.00	1800000	2000.00
41	40.78%	21	42	10.25	1845000	2050.00
42	41.96%	23	44	10.50	1890000	2100.00
43	42.75%	24	46	10.75	1935000	2150.00
44	43.92%	26	48	11.00	1980000	2200.00
45	44.71%	27	50	11.25	2025000	2250.00
46	45.88%	29	52	11.50	2070000	2300.00
47	46.67%	30	54	11.75	2115000	2350.00
48	47.84%	32	56	12.00	2160000	2400.00
49	48.63%	33	58	12.25	2205000	2450.00
50	49.80%	35	60	12.50	2250000	2500.00
51	50.98%	36	62	12.75	2295000	2550.00
52	51.76%	38	64	13.00	2340000	2600.00
53	52.94%	39	66	13.25	2385000	2650.00
54	53.73%	41	68	13.50	2430000	2700.00
55	54.90%	42	70	13.75	2475000	2750.00
56	55.69%	44	72	14.00	2520000	2800.00
57	56.86%	45	74	14.25	2565000	2850.00
58	57.65%	47	76	14.50	2610000	2900.00
59	58.82%	48	78	14.75	2655000	2950.00
60	60.00%	50	80	15.00	2700000	3000.00
61	60.78%	51	82	15.25	2745000	3050.00
62	61.96%	53	84	15.50	2790000	3100.00
63	62.75%	54	86	15.75	2835000	3150.00
64	63.92%	56	88	16.00	2880000	3200.00
65	64.71%	57	90	16.25	2925000	3250.00
66	65.88%	59	92	16.50	2970000	3300.00
67	66.67%	60	94	16.75	3015000	3350.00
68	67.84%	62	96	17.00	3060000	3400.00
69	68.63%	63	98	17.25	3105000	3450.00
70	69.80%	65	100	17.50	3150000	3500.00
71	70.98%	66	102	17.75	3195000	3550.00
72	71.76%	68	104	18.00	3240000	3600.00
73	72.94%	69	106	18.25	3285000	3650.00
74	73.73%	71	108	18.50	3330000	3700.00
75	74.90%	72	110	18.75	3375000	3750.00
76	75.69%	74	112	19.00	3420000	3800.00
77	76.86%	75	114	19.25	3465000	3850.00
78	77.65%	77	116	19.50	3510000	3900.00
79	78.82%	78	118	19.75	3555000	3950.00
80	80.00%	80	120	20.00	3600000	4000.00
81	80.78%	86	124	182.80	218168364	4619.00
82	81.96%	93	129	345.65	432736729	5238.25
83	82.75%	100	134	508.50	647305094	5857.50
84	83.92%	107	139	671.35	861873459	6476.75
85	84.71%	113	143	834.15	1076441823	7095.75
86	85.88%	120	148	997.00	1291010188	7715.00
87	86.67%	127	153	1159.85	1505578553	8334.25
88	87.84%	134	158	1322.70	1720146918	8953.50
89	88.63%	140	162	1485.50	1934715282	9572.75
90	89.80%	147	167	1648.35	2149283647	10191.75
91	90.98%	154	172	1811.20	2363852012	10811.00
92	91.76%	161	177	1974.05	2578420377	11430.25
93	92.94%	167	181	2136.85	2792988741	12049.25
94	93.73%	174	186	2299.70	3007557106	12668.50
95	94.90%	181	191	2462.55	3222125471	13287.75
96	95.69%	188	196	2625.40	3436693836	13907.00

97	96.86%	194	200	2788.25	3651262200	14526.00
98	97.65%	201	205	2951.05	3865830565	15145.25
99	98.82%	208	210	3113.90	4080398930	15764.50
100	100.00%	215	215	3276.75	4294967295	16383.75

5.3 Other Engine Parameters Simulation values

Table 5 – 8 Service \$01 Engine PID (\$06 – \$10) Simulated Values

Step	\$06/7/8/9 / \$F406/7/8/9	\$0A / \$F40A	\$0B / \$F40B	\$0D / \$F40D	\$0E / \$F40E	\$0F / \$F40F	\$10 / \$F410
	SHRTFT1 (deg)	FP (kPa)	MAP (kPa)	VSS (km/h)	SPARKADV	IAT C)	MAF (g/s)
0	-100.00%	0	0	0	-64	-40	0.00
1	-98.44%	6	2	2	-63	-36	0.80
2	-96.09%	15	5	5	-61.5	-32	1.60
3	-94.53%	21	7	7	-60.5	-28	2.40
4	-92.19%	30	10	10	-59	-24	3.20
5	-90.63%	36	12	12	-58	-20	4.00
6	-88.28%	45	15	15	-56.5	-16	4.80
7	-86.72%	51	17	17	-55.5	-12	5.60
8	-84.38%	60	20	20	-54	-8	6.40
9	-82.81%	66	22	22	-53	-4	7.20
10	-80.47%	75	25	25	-51.5	0	8.00
11	-78.13%	84	28	28	-50	1	8.80
12	-76.56%	90	30	30	-49	2	9.60
13	-74.22%	99	33	33	-47.5	3	10.40
14	-72.66%	105	35	35	-46.5	4	11.20
15	-70.31%	114	38	38	-45	5	12.00
16	-68.75%	120	40	40	-44	6	12.80
17	-66.41%	129	43	43	-42.5	7	13.60
18	-64.84%	135	45	45	-41.5	8	14.40
19	-62.50%	144	48	48	-40	9	15.20
20	-60.16%	153	51	51	-38.5	10	16.00
21	-58.59%	159	53	53	-37.5	11	16.80
22	-56.25%	168	56	56	-36	12	17.60
23	-54.69%	174	58	58	-35	13	18.40
24	-52.34%	183	61	61	-33.5	14	19.20
25	-50.78%	189	63	63	-32.5	15	20.00
26	-48.44%	198	66	66	-31	16	20.80
27	-46.88%	204	68	68	-30	17	21.60
28	-44.53%	213	71	71	-28.5	18	22.40
29	-42.97%	219	73	73	-27.5	19	23.20
30	-40.63%	228	76	76	-26	20	24.00
31	-38.28%	237	79	79	-24.5	21	24.80
32	-36.72%	243	81	81	-23.5	22	25.60
33	-35.16%	249	84	84	-22.5	23	26.40
34	-32.81%	258	86	86	-21	24	27.20
35	-30.47%	267	89	89	-19.5	25	28.00
36	-28.91%	273	91	91	-18.5	26	28.80
37	-26.56%	282	94	94	-17	27	29.60
38	-25.00%	288	96	96	-16	28	30.40
39	-22.66%	297	99	99	-14.5	29	31.20
40	-20.31%	306	102	102	-13	30	32.00
41	-18.75%	312	104	104	-12	31	32.80
42	-16.41%	321	107	107	-10.5	32	33.60
43	-14.84%	327	109	109	-9.5	33	34.40
44	-12.50%	336	112	112	-8	34	35.20

45	-10.94%	342	114	114	-7	35	36.00
46	-8.59%	351	117	117	-5.5	36	36.80
47	-7.03%	357	119	119	-4.5	37	37.60
48	-4.69%	366	122	122	-3	38	38.40
49	-3.13%	372	124	124	-2	39	39.20
50	-0.78%	381	127	127	-0.5	40	40.00
51	1.56%	390	130	130	1	41	40.80
52	3.13%	396	132	132	2	42	41.60
53	5.47%	405	135	135	3.5	43	42.40
54	7.03%	411	137	137	4.5	44	43.20
55	9.38%	420	140	140	6	45	44.00
56	10.94%	426	142	142	7	46	44.80
57	13.28%	435	145	145	8.5	47	45.60
58	14.84%	441	147	147	9.5	48	46.40
59	17.19%	450	150	150	11	49	47.20
60	19.53%	459	153	153	12.5	50	48.00
61	21.09%	465	155	155	13.5	51	48.80
62	23.44%	474	158	158	15	52	49.60
63	25.00%	480	160	160	16	53	50.40
64	27.34%	489	163	163	17.5	54	51.20
65	28.91%	495	165	165	18.5	55	52.00
66	31.25%	504	168	168	20	56	52.80
67	32.81%	510	170	170	21	57	53.60
68	35.16%	519	173	173	22.5	58	54.40
69	36.72%	525	175	175	23.5	59	55.20
70	39.06%	534	178	178	25	60	56.00
71	41.41%	543	181	181	26.5	61	56.80
72	42.97%	549	183	183	27.5	62	57.60
73	45.31%	558	186	186	29	63	58.40
74	46.88%	564	188	188	30	64	59.20
75	49.22%	573	191	191	31.5	65	60.00
76	50.78%	579	193	193	32.5	66	60.80
77	53.13%	588	196	196	34	67	61.60
78	54.69%	594	198	198	35	68	62.40
79	57.03%	603	201	201	36.5	69	63.20
80	59.38%	612	204	204	38	70	64.00
81	60.94%	618	206	206	39	76	70.40
82	63.28%	627	209	209	40.5	82	76.80
83	64.84%	633	211	211	41.5	88	83.20
84	67.19%	642	214	214	43	94	89.60
85	68.75%	648	216	216	44	100	96.00
86	71.09%	657	219	219	45.5	106	102.40
87	72.66%	663	221	221	46.5	112	108.80
88	75.00%	672	224	224	48	118	115.20
89	76.56%	678	226	226	49	124	121.60
90	78.91%	687	229	229	50.5	130	128.00
91	81.25%	696	232	232	52	138	180.73
92	82.81%	702	234	234	53	147	233.47
93	85.16%	711	237	237	54.5	155	286.20
94	86.72%	717	239	239	55.5	164	338.94
95	89.06%	726	242	242	57	172	391.67
96	90.63%	732	244	244	58	181	444.41
97	92.97%	741	247	247	59.5	189	497.14
98	94.53%	747	249	249	60.5	198	549.87
99	96.88%	756	252	252	62	206	602.60
100	99.22%	765	255	255	63.5	215	655.35

Table 5 – 9 Service \$01 Engine PID (\$11 – \$23) Simulated Values at control steps 0 to 50

	\$11 / \$F411	\$15 / \$F415	\$19 / \$F419	\$1F / \$F41F	\$21 / \$F421	\$22 / \$F422	\$23 / \$F423
Step	TP (%)	O2S (v)	SHRTFT (%)	RUNTM (sec)	MIL_DIST (km)	FP(kPa)	FRP(kPa)
0	0.00%	0.000	-100.00%	0	0	0.00	0
1	0.78%	0.010	-98.44%	655	655	51.75	6550
2	1.96%	0.025	-96.09%	1310	1310	103.49	13100
3	2.75%	0.035	-94.53%	1966	1966	155.31	19660
4	3.92%	0.050	-92.19%	2621	2621	207.06	26210
5	4.71%	0.060	-90.63%	3276	3276	258.80	32760
6	5.88%	0.075	-88.28%	3932	3932	310.63	39320
7	6.67%	0.085	-86.72%	4587	4587	362.37	45870
8	7.84%	0.100	-84.38%	5242	5242	414.12	52420
9	8.63%	0.110	-82.81%	5898	5898	465.94	58980
10	9.80%	0.125	-80.47%	6553	6553	517.69	65530
11	10.98%	0.140	-78.13%	7208	7208	569.43	72080
12	11.76%	0.150	-76.56%	7864	7864	621.26	78640
13	12.94%	0.165	-74.22%	8519	8519	673.00	85190
14	13.73%	0.175	-72.66%	9174	9174	724.75	91740
15	14.90%	0.190	-70.31%	9830	9830	776.57	98300
16	15.69%	0.200	-68.75%	10485	10485	828.32	104850
17	16.86%	0.215	-66.41%	11140	11140	880.06	111400
18	17.65%	0.225	-64.84%	11796	11796	931.88	117960
19	18.82%	0.240	-62.50%	12451	12451	983.63	124510
20	20.00%	0.255	-60.16%	13107	13107	1035.45	131070
21	20.78%	0.265	-58.59%	13762	13762	1087.20	137620
22	21.96%	0.280	-56.25%	14417	14417	1138.94	144170
23	22.75%	0.290	-54.69%	15073	15073	1190.77	150730
24	23.92%	0.305	-52.34%	15728	15728	1242.51	157280
25	24.71%	0.315	-50.78%	16383	16383	1294.26	163830
26	25.88%	0.330	-48.44%	17039	17039	1346.08	170380
27	26.67%	0.340	-46.88%	17694	17694	1397.83	176940
28	27.84%	0.355	-44.53%	18349	18349	1449.57	183490
29	28.63%	0.365	-42.97%	19005	19005	1501.40	190050
30	29.80%	0.380	-40.63%	19660	19660	1553.14	196600
31	30.98%	0.395	-38.28%	20315	20315	1604.89	203150
32	31.76%	0.405	-36.72%	20971	20971	1656.71	209710
33	32.94%	0.420	-34.38%	21626	21626	1708.46	216260
34	33.73%	0.430	-32.81%	22281	22281	1760.20	222810
35	34.90%	0.445	-30.47%	22937	22937	1812.02	229370
36	35.69%	0.455	-28.91%	23592	23592	1863.77	235920
37	36.86%	0.470	-26.56%	24247	24247	1915.51	242470
38	37.65%	0.480	-25.00%	24903	24903	1967.34	249030
39	38.82%	0.495	-22.66%	25558	25558	2019.08	255580
40	40.00%	0.510	-20.31%	26214	26214	2070.91	262140
41	40.78%	0.520	-18.75%	26869	26869	2122.66	268690
42	41.96%	0.535	-16.41%	27524	27524	2174.40	275240
43	42.75%	0.545	-14.84%	28180	28180	2226.22	281800
44	43.92%	0.560	-12.50%	28835	28835	2277.97	288350
45	44.71%	0.570	-10.94%	29490	29490	2329.71	294900
46	45.88%	0.585	-8.59%	30146	30146	2381.53	301460
47	46.67%	0.595	-7.03%	30801	30801	2433.28	308010
48	47.84%	0.610	-4.69%	31456	31456	2485.02	314560
49	48.63%	0.620	-3.13%	32112	32112	2536.85	321120
50	49.80%	0.635	-0.78%	32767	32767	2588.59	327670

Table 5 – 10 Service \$01 Engine PID (\$11 – \$23) Simulated Values at control steps 51 to 100

	\$11 / \$F411	\$15 / \$F415	\$19 / \$F419	\$1F / \$F41F	\$21 / \$F421	\$22 / \$F422	\$23 / \$F423
Step	TP (%)	O2S (v)	SHRTFT (%)	RUNTM (sec)	MIL_DIST (km)	FP(kPa)	FRP(kPa)
51	50.98%	0.650	1.56%	33422	33422	2640.34	334220
52	51.76%	0.660	3.13%	34078	34078	2692.16	340780
53	52.94%	0.675	5.47%	34733	34733	2743.91	347330
54	53.73%	0.685	7.03%	35388	35388	2795.65	353880
55	54.90%	0.700	9.38%	36044	36044	2847.48	360440
56	55.69%	0.710	10.94%	36699	36699	2899.23	366990
57	56.86%	0.725	13.28%	37354	37354	2950.97	373540
58	57.65%	0.735	14.84%	38010	38010	3002.79	380100
59	58.82%	0.750	17.19%	38665	38665	3054.54	386660
60	60.00%	0.765	19.53%	39321	39321	3106.29	393210
61	60.78%	0.775	21.09%	39976	39976	3158.10	399760
62	61.96%	0.790	23.44%	40631	40631	3209.85	406310
63	62.75%	0.800	25.00%	41287	41287	3261.67	412870
64	63.92%	0.815	27.34%	41942	41942	3313.42	419420
65	64.71%	0.825	28.91%	42597	42597	3365.16	425970
66	65.88%	0.840	31.25%	43253	43253	3416.99	432530
67	66.67%	0.850	32.81%	43908	43908	3468.73	439080
68	67.84%	0.865	35.16%	44563	44563	3520.48	445630
69	68.63%	0.875	36.72%	45219	45219	3572.30	452190
70	69.80%	0.890	39.06%	45874	45874	3624.05	458740
71	70.98%	0.905	41.41%	46529	46529	3675.79	465290
72	71.76%	0.915	42.97%	47185	47185	3727.62	471850
73	72.94%	0.930	45.31%	47840	47840	3779.36	478400
74	73.73%	0.940	46.88%	48495	48495	3831.11	484950
75	74.90%	0.955	49.22%	49151	49151	3882.93	491510
76	75.69%	0.965	50.78%	49806	49806	3934.67	498060
77	76.86%	0.980	53.13%	50461	50461	3986.42	504610
78	77.65%	0.990	54.69%	51117	51117	4038.24	511170
79	78.82%	1.005	57.03%	51772	51772	4089.99	517720
80	80.00%	1.020	59.38%	52428	52428	4141.81	524280
81	80.78%	1.030	60.94%	53083	53083	4193.56	530830
82	81.96%	1.045	63.28%	53738	53738	4245.30	537380
83	82.75%	1.055	64.84%	54394	54394	4297.13	543940
84	83.92%	1.070	67.19%	55049	55049	4348.87	550490
85	84.71%	1.080	68.75%	55704	55704	4400.62	557040
86	85.88%	1.095	71.09%	56360	56360	4452.44	563600
87	86.67%	1.105	72.66%	57015	57015	4504.19	570150
88	87.84%	1.120	75.00%	57670	57670	4555.93	576700
89	88.63%	1.130	76.56%	58326	58326	4607.75	583260
90	89.80%	1.145	78.91%	58981	58981	4659.50	589810
91	90.98%	1.160	81.25%	59636	59636	4711.24	596360
92	91.76%	1.170	82.81%	60292	60292	4763.07	602920
93	92.94%	1.185	85.16%	60947	60947	4814.81	609470
94	93.73%	1.195	86.72%	61602	61602	4866.56	616020
95	94.90%	1.210	89.06%	62258	62258	4918.38	622580
96	95.69%	1.220	90.63%	62913	62913	4970.12	629130
97	96.86%	1.235	92.97%	63568	63568	5021.87	635680
98	97.65%	1.245	94.53%	64224	64224	5073.70	642240
99	98.82%	1.260	96.88%	64879	64879	5125.44	648790
100	100.00%	1.275	99.22%	65535	65535	5177.27	655350

Table 5 – 11 Service \$01 Engine PID (\$2C – \$32) Simulated Values at control steps 0 to 51

	\$2C / \$F42C	\$2D / \$F42D	\$2E / \$F42E	\$2F / \$F42F	\$30 / \$F430	\$31 / \$F431	\$32 / \$F432
Step	EGR_PCT	EGR_ERR	EVAP_PCT	FLI	WARM_UPS	CLR_DIST (km)	EVAP_VP (pa)
0	0.00%	-100.00%	0.00%	0.00%	0	0	-8192.00
1	0.78%	-98.44%	0.78%	0.78%	2	655	-8028.25
2	1.96%	-96.09%	1.96%	1.96%	5	1310	-7864.50
3	2.75%	-94.53%	2.75%	2.75%	7	1966	-7700.50
4	3.92%	-92.19%	3.92%	3.92%	10	2621	-7536.75
5	4.71%	-90.63%	4.71%	4.71%	12	3276	-7373.00
6	5.88%	-88.28%	5.88%	5.88%	15	3932	-7209.00
7	6.67%	-86.72%	6.67%	6.67%	17	4587	-7045.25
8	7.84%	-84.38%	7.84%	7.84%	20	5242	-6881.50
9	8.63%	-82.81%	8.63%	8.63%	22	5898	-6717.50
10	9.80%	-80.47%	9.80%	9.80%	25	6553	-6553.75
11	10.98%	-78.13%	10.98%	10.98%	28	7208	-6390.00
12	11.76%	-76.56%	11.76%	11.76%	30	7864	-6226.00
13	12.94%	-74.22%	12.94%	12.94%	33	8519	-6062.25
14	13.73%	-72.66%	13.73%	13.73%	35	9174	-5898.50
15	14.90%	-70.31%	14.90%	14.90%	38	9830	-5734.50
16	15.69%	-68.75%	15.69%	15.69%	40	10485	-5570.75
17	16.86%	-66.41%	16.86%	16.86%	43	11140	-5407.00
18	17.65%	-64.84%	17.65%	17.65%	45	11796	-5243.00
19	18.82%	-62.50%	18.82%	18.82%	48	12451	-5079.25
20	20.00%	-60.16%	20.00%	20.00%	51	13107	-4915.50
21	20.78%	-58.59%	20.78%	20.78%	53	13762	-4751.50
22	21.96%	-56.25%	21.96%	21.96%	56	14417	-4587.75
23	22.75%	-54.69%	22.75%	22.75%	58	15073	-4423.75
24	23.92%	-52.34%	23.92%	23.92%	61	15728	-4260.00
25	24.71%	-50.78%	24.71%	24.71%	63	16383	-4096.25
26	25.88%	-48.44%	25.88%	25.88%	66	17039	-3932.25
27	26.67%	-46.88%	26.67%	26.67%	68	17694	-3768.50
28	27.84%	-44.53%	27.84%	27.84%	71	18349	-3604.75
29	28.63%	-42.97%	28.63%	28.63%	73	19005	-3440.75
30	29.80%	-40.63%	29.80%	29.80%	76	19660	-3277.00
31	30.98%	-38.28%	30.98%	30.98%	79	20315	-3113.25
32	31.76%	-36.72%	31.76%	31.76%	81	20971	-2949.25
33	32.94%	-34.38%	32.94%	32.94%	84	21626	-2785.50
34	33.73%	-32.81%	33.73%	33.73%	86	22281	-2621.75
35	34.90%	-30.47%	34.90%	34.90%	89	22937	-2457.75
36	35.69%	-28.91%	35.69%	35.69%	91	23592	-2294.00
37	36.86%	-26.56%	36.86%	36.86%	94	24247	-2130.25
38	37.65%	-25.00%	37.65%	37.65%	96	24903	-1966.25
39	38.82%	-22.66%	38.82%	38.82%	99	25558	-1802.50
40	40.00%	-20.31%	40.00%	40.00%	102	26214	-1638.50
41	40.78%	-18.75%	40.78%	40.78%	104	26869	-1474.75
42	41.96%	-16.41%	41.96%	41.96%	107	27524	-1311.00
43	42.75%	-14.84%	42.75%	42.75%	109	28180	-1147.00
44	43.92%	-12.50%	43.92%	43.92%	112	28835	-983.25
45	44.71%	-10.94%	44.71%	44.71%	114	29490	-819.50
46	45.88%	-8.59%	45.88%	45.88%	117	30146	-655.50
47	46.67%	-7.03%	46.67%	46.67%	119	30801	-491.75
48	47.84%	-4.69%	47.84%	47.84%	122	31456	-328.00
49	48.63%	-3.13%	48.63%	48.63%	124	32112	-164.00
50	49.80%	-0.78%	49.80%	49.80%	127	32767	-0.25

Table 5 – 12 Service \$01 Engine PID (\$2C – \$32) Simulated Values at control steps 51 to 100

Step	\$2C / \$F42C	\$2D / \$F42D	\$2E / \$F42E	\$2F / \$F42F	\$30 / \$F430	\$31 / \$F431	\$32 / \$F432
	EGR_PCT	EGR_ERR	EVAP_PCT	FLI	WARM_UPS	CLR_DIST (km)	EVAP_VP (pa)
51	50.98%	1.56%	50.98%	50.98%	130	33422	163.50
52	51.76%	3.13%	51.76%	51.76%	132	34078	327.50
53	52.94%	5.47%	52.94%	52.94%	135	34733	491.25
54	53.73%	7.03%	53.73%	53.73%	137	35388	655.00
55	54.90%	9.38%	54.90%	54.90%	140	36044	819.00
56	55.69%	10.94%	55.69%	55.69%	142	36699	982.75
57	56.86%	13.28%	56.86%	56.86%	145	37354	1146.50
58	57.65%	14.84%	57.65%	57.65%	147	38010	1310.50
59	58.82%	17.19%	58.82%	58.82%	150	38665	1474.25
60	60.00%	19.53%	60.00%	60.00%	153	39321	1638.25
61	60.78%	21.09%	60.78%	60.78%	155	39976	1802.00
62	61.96%	23.44%	61.96%	61.96%	158	40631	1965.75
63	62.75%	25.00%	62.75%	62.75%	160	41287	2129.75
64	63.92%	27.34%	63.92%	63.92%	163	41942	2293.50
65	64.71%	28.91%	64.71%	64.71%	165	42597	2457.25
66	65.88%	31.25%	65.88%	65.88%	168	43253	2621.25
67	66.67%	32.81%	66.67%	66.67%	170	43908	2785.00
68	67.84%	35.16%	67.84%	67.84%	173	44563	2948.75
69	68.63%	36.72%	68.63%	68.63%	175	45219	3112.75
70	69.80%	39.06%	69.80%	69.80%	178	45874	3276.50
71	70.98%	41.41%	70.98%	70.98%	181	46529	3440.25
72	71.76%	42.97%	71.76%	71.76%	183	47185	3604.25
73	72.94%	45.31%	72.94%	72.94%	186	47840	3768.00
74	73.73%	46.88%	73.73%	73.73%	188	48495	3931.75
75	74.90%	49.22%	74.90%	74.90%	191	49151	4095.75
76	75.69%	50.78%	75.69%	75.69%	193	49806	4259.50
77	76.86%	53.13%	76.86%	76.86%	196	50461	4423.25
78	77.65%	54.69%	77.65%	77.65%	198	51117	4587.25
79	78.82%	57.03%	78.82%	78.82%	201	51772	4751.00
80	80.00%	59.38%	80.00%	80.00%	204	52428	4915.00
81	80.78%	60.94%	80.78%	80.78%	206	53083	5078.75
82	81.96%	63.28%	81.96%	81.96%	209	53738	5242.50
83	82.75%	64.84%	82.75%	82.75%	211	54394	5406.50
84	83.92%	67.19%	83.92%	83.92%	214	55049	5570.25
85	84.71%	68.75%	84.71%	84.71%	216	55704	5734.00
86	85.88%	71.09%	85.88%	85.88%	219	56360	5898.00
87	86.67%	72.66%	86.67%	86.67%	221	57015	6061.75
88	87.84%	75.00%	87.84%	87.84%	224	57670	6225.50
89	88.63%	76.56%	88.63%	88.63%	226	58326	6389.50
90	89.80%	78.91%	89.80%	89.80%	229	58981	6553.25
91	90.98%	81.25%	90.98%	90.98%	232	59636	6717.00
92	91.76%	82.81%	91.76%	91.76%	234	60292	6881.00
93	92.94%	85.16%	92.94%	92.94%	237	60947	7044.75
94	93.73%	86.72%	93.73%	93.73%	239	61602	7208.50
95	94.90%	89.06%	94.90%	94.90%	242	62258	7372.50
96	95.69%	90.63%	95.69%	95.69%	244	62913	7536.25
97	96.86%	92.97%	96.86%	96.86%	247	63568	7700.00
98	97.65%	94.53%	97.65%	97.65%	249	64224	7864.00
99	98.82%	96.88%	98.82%	98.82%	252	64879	8027.75
100	100.00%	99.22%	100.00%	100.00%	255	65535	8191.75

Table 5 – 13 Service \$01 Engine PID (\$33 – \$44) Simulated Values at control steps 0 to 50

Step	\$33 / \$F433	\$34/38 / \$F434/F438	\$34/38 / \$F434/F438	\$3C/3D/3E / \$F43C/3D/3E	\$42 / \$F442	\$43 / \$F443	\$44 / \$F444
	BARO	LAMBDA	O2S	CATEMP11/21/12	VPWR	LOAD_ABS	LAMBDA
0	0	0.000000000	-128.00000000	-40.0	0.000	0.00%	0.000000000
1	2	0.019989319	-125.44140625	4.0	0.400	1.18%	0.019989319
2	5	0.039978637	-122.88281250	48.0	0.800	2.35%	0.039978637
3	7	0.059998474	-120.32031250	92.0	1.200	3.53%	0.059998474
4	10	0.079987793	-117.76171875	136.0	1.600	4.70%	0.079987793
5	12	0.099977111	-115.20312500	180.0	2.000	5.88%	0.099977111
6	15	0.119996948	-112.64062500	224.0	2.400	7.45%	0.119996948
7	17	0.139986267	-110.08203125	268.0	2.800	8.63%	0.139986267
8	20	0.159975586	-107.52343750	312.0	3.200	9.80%	0.159975586
9	22	0.179995422	-104.96093750	356.0	3.600	10.98%	0.179995422
10	25	0.199984741	-102.40234375	400.0	4.000	12.16%	0.199984741
11	28	0.219974060	-99.84375000	402.8	4.400	13.73%	0.219974060
12	30	0.239993896	-97.28125000	405.7	4.800	14.90%	0.239993896
13	33	0.259983215	-94.72265625	408.5	5.200	16.08%	0.259983215
14	35	0.279972534	-92.16406250	411.4	5.600	17.25%	0.279972534
15	38	0.299992370	-89.60156250	414.2	6.000	18.43%	0.299992370
16	40	0.319981689	-87.04296875	417.1	6.400	20.00%	0.319981689
17	43	0.339971008	-84.48437500	420.0	6.800	21.18%	0.339971008
18	45	0.359990845	-81.92187500	422.8	7.200	22.35%	0.359990845
19	48	0.379980163	-79.36328125	425.7	7.600	23.53%	0.379980163
20	51	0.400000000	-76.80078125	428.5	8.000	24.71%	0.400000000
21	53	0.419989319	-74.24218750	431.4	8.400	25.88%	0.419989319
22	56	0.439978637	-71.68359375	434.2	8.800	27.45%	0.439978637
23	58	0.459998474	-69.12109375	437.1	9.200	28.63%	0.459998474
24	61	0.479987793	-66.56250000	440.0	9.600	29.80%	0.479987793
25	63	0.499977111	-64.00390625	442.8	10.000	30.98%	0.499977111
26	66	0.519996948	-61.44140625	445.7	10.400	32.16%	0.519996948
27	68	0.539986267	-58.88281250	448.5	10.800	33.73%	0.539986267
28	71	0.559975586	-56.32421875	451.4	11.200	34.90%	0.559975586
29	73	0.579995422	-53.76171875	454.2	11.600	36.08%	0.579995422
30	76	0.599984741	-51.20312500	457.1	12.000	37.25%	0.599984741
31	79	0.619974060	-48.64453125	460.0	12.400	38.43%	0.619974060
32	81	0.639993896	-46.08203125	462.8	12.800	40.00%	0.639993896
33	84	0.659983215	-43.52343750	465.7	13.200	41.18%	0.659983215
34	86	0.679972534	-40.96484375	468.5	13.600	42.35%	0.679972534
35	89	0.699992370	-38.40234375	471.4	14.000	43.53%	0.699992370
36	91	0.719981689	-35.84375000	474.2	14.400	44.71%	0.719981689
37	94	0.739971008	-33.28515625	477.1	14.800	45.88%	0.739971008
38	96	0.759990845	-30.72265625	480.0	15.200	47.45%	0.759990845
39	99	0.779980163	-28.16406250	482.8	15.600	48.63%	0.779980163
40	102	0.800000000	-25.60156250	485.7	16.000	49.80%	0.800000000
41	104	0.819989319	-23.04296875	488.5	16.400	50.98%	0.819989319
42	107	0.839978637	-20.48437500	491.4	16.800	52.16%	0.839978637
43	109	0.859998474	-17.92187500	494.2	17.200	53.73%	0.859998474
44	112	0.879987793	-15.36328125	497.1	17.600	54.90%	0.879987793
45	114	0.899977111	-12.80468750	500.0	18.000	56.08%	0.899977111
46	117	0.919996948	-10.24218750	502.8	18.400	57.25%	0.919996948
47	119	0.939986267	-7.68359375	505.7	18.800	58.43%	0.939986267
48	122	0.959975586	-5.12500000	508.5	19.200	60.00%	0.959975586
49	124	0.979995422	-2.56250000	511.4	19.600	61.18%	0.979995422
50	127	0.999984741	-0.00390625	514.2	20.000	62.35%	0.999984741

Table 5 – 14 Service \$01 Engine PID ((\$33 – \$44) Simulated Values at control steps 51 to 100

Step	\$33 / \$F433	\$34/38 / \$F434/F438	\$34/38 / \$F434/F438	\$3C/3D/3E / \$F43C/3D/3E	\$42 / \$F442	\$43 / \$F443	\$44 / \$F444
	BARO	LAMBDA	O2S	CATEMP11/21/12	VPWR	LOAD_ABS	LAMBDA
51	130	1.019974060	2.55468750	517.1	20.400	63.53%	1.019974060
52	132	1.039993896	5.11718750	520.0	20.800	64.71%	1.039993896
53	135	1.059983215	7.67578125	522.8	21.200	65.88%	1.059983215
54	137	1.079972534	10.23437500	525.7	21.600	67.45%	1.079972534
55	140	1.099992370	12.79687500	528.5	22.000	68.63%	1.099992370
56	142	1.119981689	15.35546875	531.4	22.400	69.80%	1.119981689
57	145	1.139971008	17.91406250	534.2	22.800	70.98%	1.139971008
58	147	1.159990845	20.47656250	537.1	23.200	72.16%	1.159990845
59	150	1.179980163	23.03515625	540.0	23.600	73.73%	1.179980163
60	153	1.200000000	25.59765625	542.8	24.000	74.90%	1.200000000
61	155	1.219989319	28.15625000	545.7	24.400	76.08%	1.219989319
62	158	1.239978637	30.71484375	548.5	24.800	77.25%	1.239978637
63	160	1.259998474	33.27734375	551.4	25.200	78.43%	1.259998474
64	163	1.279987793	35.83593750	554.2	25.600	80.00%	1.279987793
65	165	1.299977111	38.39453125	557.1	26.000	81.18%	1.299977111
66	168	1.319996948	40.95703125	560.0	26.400	82.35%	1.319996948
67	170	1.339986267	43.51562500	562.8	26.800	83.53%	1.339986267
68	173	1.359975586	46.07421875	565.7	27.200	84.71%	1.359975586
69	175	1.379995422	48.63671875	568.5	27.600	85.88%	1.379995422
70	178	1.399984741	51.19531250	571.4	28.000	87.45%	1.399984741
71	181	1.419974060	53.75390625	574.2	28.400	88.63%	1.419974060
72	183	1.439993896	56.31640625	577.1	28.800	89.80%	1.439993896
73	186	1.459983215	58.87500000	580.0	29.200	90.98%	1.459983215
74	188	1.479972534	61.43359375	582.8	29.600	92.16%	1.479972534
75	191	1.499992370	63.99609375	585.7	30.000	93.73%	1.499992370
76	193	1.519981689	66.55468750	588.5	30.400	94.90%	1.519981689
77	196	1.539971008	69.11328125	591.4	30.800	96.08%	1.539971008
78	198	1.559990845	71.67578125	594.2	31.200	97.25%	1.559990845
79	201	1.579980163	74.23437500	597.1	31.600	98.43%	1.579980163
80	204	1.600000000	76.79687500	600.0	32.000	100.00%	1.600000000
81	206	1.619989319	79.35546875	615.0	33.676	129.80%	1.619989319
82	209	1.639978637	81.91406250	630.0	35.353	160.00%	1.639978637
83	211	1.659998474	84.47656250	645.0	37.030	189.80%	1.659998474
84	214	1.679987793	87.03515625	660.0	38.707	220.00%	1.679987793
85	216	1.699977111	89.59375000	675.0	40.383	249.80%	1.699977111
86	219	1.719996948	92.15625000	690.0	42.060	280.00%	1.719996948
87	221	1.739986267	94.71484375	705.0	43.737	309.80%	1.739986267
88	224	1.759975586	97.27343750	720.0	45.414	340.00%	1.759975586
89	226	1.779995422	99.83593750	735.0	47.090	369.80%	1.779995422
90	229	1.799984741	102.39453125	750.0	48.767	400.00%	1.799984741
91	232	1.819974060	104.95312500	1326.3	50.444	2929.80%	1.819974060
92	234	1.839993896	107.51562500	1902.7	52.121	5460.00%	1.839993896
93	237	1.859983215	110.07421875	2479.0	53.797	7989.80%	1.859983215
94	239	1.879972534	112.63281250	3055.4	55.474	10520.00%	1.879972534
95	242	1.899992370	115.19531250	3631.7	57.151	13049.80%	1.899992370
96	244	1.919981689	117.75390625	4208.1	58.828	15580.00%	1.919981689
97	247	1.939971008	120.31250000	4784.4	60.504	18109.80%	1.939971008
98	249	1.959990845	122.87500000	5360.8	62.181	20640.00%	1.959990845
99	252	1.979980163	125.43359375	5937.1	63.858	23169.80%	1.979980163
100	255	2.000000000	127.99609375	6513.5	65.535	25700.00%	2.000000000

Table 5 – 15 Service \$01 Engine PID (\$45 – \$A6) Simulated Values at control steps 0 to 50

	\$45/47 / \$F445/F447	\$46 / \$F446	\$49/4A/4C / \$F449/4A/4C	\$4D/4E / \$F44D/F44E	\$55/56 / \$F455/F456	\$59 / \$F459	\$A6 / \$F4A6
Step	TP_R/TP_B	AAT	APP_D/ APP_E/TAC_PCT	MIL_TIME / CLR_TIME (min)	STSO2FT1/ LGSO2FT1	FRP	ODO (km)
0	0.00%	0.00%	0.00%	0	-100.00%	0	0.0
1	0.78%	0.78%	0.78%	655	-98.44%	6550	50.0
2	1.96%	1.96%	1.96%	1310	-96.09%	13100	100.0
3	2.75%	2.75%	2.75%	1966	-94.53%	19660	150.0
4	3.92%	3.92%	3.92%	2621	-92.19%	26210	200.0
5	4.71%	4.71%	4.71%	3276	-90.63%	32760	250.0
6	5.88%	5.88%	5.88%	3932	-88.28%	39320	300.0
7	6.67%	6.67%	6.67%	4587	-86.72%	45870	350.0
8	7.84%	7.84%	7.84%	5242	-84.38%	52420	400.0
9	8.63%	8.63%	8.63%	5898	-82.81%	58980	450.0
10	9.80%	9.80%	9.80%	6553	-80.47%	65530	500.0
11	10.98%	10.98%	10.98%	7208	-78.13%	72080	550.0
12	11.76%	11.76%	11.76%	7864	-76.56%	78640	600.0
13	12.94%	12.94%	12.94%	8519	-74.22%	85190	650.0
14	13.73%	13.73%	13.73%	9174	-72.66%	91740	700.0
15	14.90%	14.90%	14.90%	9830	-70.31%	98300	750.0
16	15.69%	15.69%	15.69%	10485	-68.75%	104850	800.0
17	16.86%	16.86%	16.86%	11140	-66.41%	111400	850.0
18	17.65%	17.65%	17.65%	11796	-64.84%	117960	900.0
19	18.82%	18.82%	18.82%	12451	-62.50%	124510	950.0
20	20.00%	20.00%	20.00%	13107	-60.16%	131070	1000.0
21	20.78%	20.78%	20.78%	13762	-58.59%	137620	1050.0
22	21.96%	21.96%	21.96%	14417	-56.25%	144170	1100.0
23	22.75%	22.75%	22.75%	15073	-54.69%	150730	1150.0
24	23.92%	23.92%	23.92%	15728	-52.34%	157280	1200.0
25	24.71%	24.71%	24.71%	16383	-50.78%	163830	1250.0
26	25.88%	25.88%	25.88%	17039	-48.44%	170380	1300.0
27	26.67%	26.67%	26.67%	17694	-46.88%	176940	1350.0
28	27.84%	27.84%	27.84%	18349	-44.53%	183490	1400.0
29	28.63%	28.63%	28.63%	19005	-42.97%	190050	1450.0
30	29.80%	29.80%	29.80%	19660	-40.63%	196600	1500.0
31	30.98%	30.98%	30.98%	20315	-38.28%	203150	1550.0
32	31.76%	31.76%	31.76%	20971	-36.72%	209710	1600.0
33	32.94%	32.94%	32.94%	21626	-34.38%	216260	1650.0
34	33.73%	33.73%	33.73%	22281	-32.81%	222810	1700.0
35	34.90%	34.90%	34.90%	22937	-30.47%	229370	1750.0
36	35.69%	35.69%	35.69%	23592	-28.91%	235920	1800.0
37	36.86%	36.86%	36.86%	24247	-26.56%	242470	1850.0
38	37.65%	37.65%	37.65%	24903	-25.00%	249030	1900.0
39	38.82%	38.82%	38.82%	25558	-22.66%	255580	1950.0
40	40.00%	40.00%	40.00%	26214	-20.31%	262140	2000.0
41	40.78%	40.78%	40.78%	26869	-18.75%	268690	2050.0
42	41.96%	41.96%	41.96%	27524	-16.41%	275240	2100.0
43	42.75%	42.75%	42.75%	28180	-14.84%	281800	2150.0
44	43.92%	43.92%	43.92%	28835	-12.50%	288350	2200.0
45	44.71%	44.71%	44.71%	29490	-10.94%	294900	2250.0
46	45.88%	45.88%	45.88%	30146	-8.59%	301460	2300.0
47	46.67%	46.67%	46.67%	30801	-7.03%	308010	2350.0
48	47.84%	47.84%	47.84%	31456	-4.69%	314560	2400.0
49	48.63%	48.63%	48.63%	32112	-3.13%	321120	2450.0
50	49.80%	49.80%	49.80%	32767	-0.78%	327670	2500.0

Table 5 – 16 Service \$01 Engine PID (\$45 – \$A6) Simulated Values at control steps 51 to 100

Step	\$45/47 / \$F445/F447	\$46 / \$F446	\$49/4A/4C / \$F449/4A/4C	\$4D/4E / \$F44D/F44E	\$55/56 / \$F455/F456	\$59 / \$F459	\$A6 / \$F4A6
	TP_R/ TP_B	AAT	APP_D/ APP_E/TAC_PCT	MIL_TIME /CLR_TIME (min)	STSO2FT1/ LGSO2FT1	FRP	ODO (km)
51	50.98%	50.98%	50.98%	33422	1.56%	334220	2550.0
52	51.76%	51.76%	51.76%	34078	3.13%	340780	2600.0
53	52.94%	52.94%	52.94%	34733	5.47%	347330	2650.0
54	53.73%	53.73%	53.73%	35388	7.03%	353880	2700.0
55	54.90%	54.90%	54.90%	36044	9.38%	360440	2750.0
56	55.69%	55.69%	55.69%	36699	10.94%	366990	2800.0
57	56.86%	56.86%	56.86%	37354	13.28%	373540	2850.0
58	57.65%	57.65%	57.65%	38010	14.84%	380100	2900.0
59	58.82%	58.82%	58.82%	38665	17.19%	386660	2950.0
60	60.00%	60.00%	60.00%	39320	19.53%	393210	3000.0
61	60.78%	60.78%	60.78%	39976	21.09%	399760	3050.0
62	61.96%	61.96%	61.96%	40631	23.44%	406310	3100.0
63	62.75%	62.75%	62.75%	41287	25.00%	412870	3150.0
64	63.92%	63.92%	63.92%	41942	27.34%	419420	3200.0
65	64.71%	64.71%	64.71%	42597	28.91%	425970	3250.0
66	65.88%	65.88%	65.88%	43253	31.25%	432530	3300.0
67	66.67%	66.67%	66.67%	43908	32.81%	439080	3350.0
68	67.84%	67.84%	67.84%	44563	35.16%	445630	3400.0
69	68.63%	68.63%	68.63%	45219	36.72%	452190	3450.0
70	69.80%	69.80%	69.80%	45874	39.06%	458740	3500.0
71	70.98%	70.98%	70.98%	46529	41.41%	465290	3550.0
72	71.76%	71.76%	71.76%	47185	42.97%	471850	3600.0
73	72.94%	72.94%	72.94%	47840	45.31%	478400	3650.0
74	73.73%	73.73%	73.73%	48495	46.88%	484950	3700.0
75	74.90%	74.90%	74.90%	49151	49.22%	491510	3750.0
76	75.69%	75.69%	75.69%	49806	50.78%	498060	3800.0
77	76.86%	76.86%	76.86%	50461	53.13%	504610	3850.0
78	77.65%	77.65%	77.65%	51117	54.69%	511170	3900.0
79	78.82%	78.82%	78.82%	51772	57.03%	517720	3950.0
80	80.00%	80.00%	80.00%	52428	59.38%	524280	4000.0
81	80.78%	80.78%	80.78%	53083	60.94%	530830	21478636.4
82	81.96%	81.96%	81.96%	53738	63.28%	537380	42953272.9
83	82.75%	82.75%	82.75%	54394	64.84%	543940	64427909.4
84	83.92%	83.92%	83.92%	55049	67.19%	550490	85902545.9
85	84.71%	84.71%	84.71%	55704	68.75%	557040	107377182.3
86	85.88%	85.88%	85.88%	56360	71.09%	563600	128851818.8
87	86.67%	86.67%	86.67%	57015	72.66%	570150	150326455.3
88	87.84%	87.84%	87.84%	57670	75.00%	576700	171801091.8
89	88.63%	88.63%	88.63%	58326	76.56%	583260	193275728.2
90	89.80%	89.80%	89.80%	58981	78.91%	589810	214750364.7
91	90.98%	90.98%	90.98%	59636	81.25%	596360	236225001.2
92	91.76%	91.76%	91.76%	60292	82.81%	602920	257699637.7
93	92.94%	92.94%	92.94%	60947	85.16%	609470	279174274.1
94	93.73%	93.73%	93.73%	61602	86.72%	616020	300648910.6
95	94.90%	94.90%	94.90%	62258	89.06%	622580	322123547.1
96	95.69%	95.69%	95.69%	62913	90.63%	629130	343598183.6
97	96.86%	96.86%	96.86%	63568	92.97%	635680	365072820.0
98	97.65%	97.65%	97.65%	64224	94.53%	642240	386547456.5
99	98.82%	98.82%	98.82%	64879	96.88%	648790	408022093.0
100	100.00%	100.00%	100.00%	65535	99.22%	655350	429496729.5

Table 5 – 17 Service \$09 Engine PID (\$17 – \$0C) Simulated Values at control steps 1 to 50

Step	\$17/ \$F817 / \$1A/\$F81A		\$17/ \$F81B / \$1B/\$F81B		\$1C/ \$F81C	\$1C/ \$F81C
	DT-R (km)	DT-L (km)	FC - R (Liters)	FC - L(Liters)	GE-R (kWh)	GE-L (kWh)
0	0.0	0.0	0.00	0.00	0.0	0.0
1	25.0	50.0	2.50	5.00	25.0	50.0
2	50.0	100.0	5.00	10.00	50.0	100.0
3	75.0	150.0	7.50	15.00	75.0	150.0
4	100.0	200.0	10.00	20.00	100.0	200.0
5	125.0	250.0	12.50	25.00	125.0	250.0
6	150.0	300.0	15.00	30.00	150.0	300.0
7	175.0	350.0	17.50	35.00	175.0	350.0
8	200.0	400.0	20.00	40.00	200.0	400.0
9	225.0	450.0	22.50	45.00	225.0	450.0
10	250.0	500.0	25.00	50.00	250.0	500.0
11	275.0	550.0	27.50	55.00	275.0	550.0
12	300.0	600.0	30.00	60.00	300.0	600.0
13	325.0	650.0	32.50	65.00	325.0	650.0
14	350.0	700.0	35.00	70.00	350.0	700.0
15	375.0	750.0	37.50	75.00	375.0	750.0
16	400.0	800.0	40.00	80.00	400.0	800.0
17	425.0	850.0	42.50	85.00	425.0	850.0
18	450.0	900.0	45.00	90.00	450.0	900.0
19	475.0	950.0	47.50	95.00	475.0	950.0
20	500.0	1000.0	50.00	100.00	500.0	1000.0
21	525.0	1050.0	52.50	105.00	525.0	1050.0
22	550.0	1100.0	55.00	110.00	550.0	1100.0
23	575.0	1150.0	57.50	115.00	575.0	1150.0
24	600.0	1200.0	60.00	120.00	600.0	1200.0
25	625.0	1250.0	62.50	125.00	625.0	1250.0
26	650.0	1300.0	65.00	130.00	650.0	1300.0
27	675.0	1350.0	67.50	135.00	675.0	1350.0
28	700.0	1400.0	70.00	140.00	700.0	1400.0
29	725.0	1450.0	72.50	145.00	725.0	1450.0
30	750.0	1500.0	75.00	150.00	750.0	1500.0
31	775.0	1550.0	77.50	155.00	775.0	1550.0
32	800.0	1600.0	80.00	160.00	800.0	1600.0
33	825.0	1650.0	82.50	165.00	825.0	1650.0
34	850.0	1700.0	85.00	170.00	850.0	1700.0
35	875.0	1750.0	87.50	175.00	875.0	1750.0
36	900.0	1800.0	90.00	180.00	900.0	1800.0
37	925.0	1850.0	92.50	185.00	925.0	1850.0
38	950.0	1900.0	95.00	190.00	950.0	1900.0
39	975.0	1950.0	97.50	195.00	975.0	1950.0
40	1000.0	2000.0	100.00	200.00	1000.0	2000.0
41	1025.0	2050.0	102.50	205.00	1025.0	2050.0
42	1050.0	2100.0	105.00	210.00	1050.0	2100.0
43	1075.0	2150.0	107.50	215.00	1075.0	2150.0
44	1100.0	2200.0	110.00	220.00	1100.0	2200.0
45	1125.0	2250.0	112.50	225.00	1125.0	2250.0
46	1150.0	2300.0	115.00	230.00	1150.0	2300.0
47	1175.0	2350.0	117.50	235.00	1175.0	2350.0
48	1200.0	2400.0	120.00	240.00	1200.0	2400.0
49	1225.0	2450.0	122.50	245.00	1225.0	2450.0
50	1250.0	2500.0	125.00	250.00	1250.0	2500.0

Table 5 – 18 Service \$09 Engine PID (\$17 – \$0C) Simulated Values at control steps 51 to 100

Step	\$17/ \$F817 / \$1A/\$F81A		\$17/ \$F81B / \$1A/\$F81B		\$1C/ \$F81C	\$1C/ \$F81C
	DT-R (km)	DT-L (km)	FC - R (Liters)	FC - L(Liters)	GE-R (kWh)	GE-L (kWh)
51	1275.0	2550.0	127.50	255.00	1275.0	2550.0
52	1300.0	2600.0	130.00	260.00	1300.0	2600.0
53	1325.0	2650.0	132.50	265.00	1325.0	2650.0
54	1350.0	2700.0	135.00	270.00	1350.0	2700.0
55	1375.0	2750.0	137.50	275.00	1375.0	2750.0
56	1400.0	2800.0	140.00	280.00	1400.0	2800.0
57	1425.0	2850.0	142.50	285.00	1425.0	2850.0
58	1450.0	2900.0	145.00	290.00	1450.0	2900.0
59	1475.0	2950.0	147.50	295.00	1475.0	2950.0
60	1500.0	3000.0	150.00	300.00	1500.0	3000.0
61	1525.0	3050.0	152.50	305.00	1525.0	3050.0
62	1550.0	3100.0	155.00	310.00	1550.0	3100.0
63	1575.0	3150.0	157.50	315.00	1575.0	3150.0
64	1600.0	3200.0	160.00	320.00	1600.0	3200.0
65	1625.0	3250.0	162.50	325.00	1625.0	3250.0
66	1650.0	3300.0	165.00	330.00	1650.0	3300.0
67	1675.0	3350.0	167.50	335.00	1675.0	3350.0
68	1700.0	3400.0	170.00	340.00	1700.0	3400.0
69	1725.0	3450.0	172.50	345.00	1725.0	3450.0
70	1750.0	3500.0	175.00	350.00	1750.0	3500.0
71	1775.0	3550.0	177.50	355.00	1775.0	3550.0
72	1800.0	3600.0	180.00	360.00	1800.0	3600.0
73	1825.0	3650.0	182.50	365.00	1825.0	3650.0
74	1850.0	3700.0	185.00	370.00	1850.0	3700.0
75	1875.0	3750.0	187.50	375.00	1875.0	3750.0
76	1900.0	3800.0	190.00	380.00	1900.0	3800.0
77	1925.0	3850.0	192.50	385.00	1925.0	3850.0
78	1950.0	3900.0	195.00	390.00	1950.0	3900.0
79	1975.0	3950.0	197.50	395.00	1975.0	3950.0
80	2000.0	4000.0	200.00	400.00	2000.0	4000.0
81	10739318.2	21478636.4	1073931.82	2147863.64	10739318.2	21478636.4
82	21476636.4	42953272.8	2147663.64	4295327.28	21476636.4	42953272.8
83	32213954.7	64427909.4	3221395.47	6442790.94	32213954.7	64427909.4
84	42951272.9	85902545.8	4295127.29	8590254.58	42951272.9	85902545.8
85	53688591.1	107377182.2	5368859.11	10737718.22	53688591.1	107377182.2
86	64425909.4	128851818.8	6442590.94	12885181.88	64425909.4	128851818.8
87	75163227.6	150326455.2	7516322.76	15032645.52	75163227.6	150326455.2
88	85900545.9	171801091.8	8590054.59	17180109.18	85900545.9	171801091.8
89	96637864.1	193275728.2	9663786.41	19327572.82	96637864.1	193275728.2
90	107375182.3	214750364.6	10737518.23	21475036.46	107375182.3	214750364.6
91	118112500.6	236225001.2	11811250.06	23622500.12	118112500.6	236225001.2
92	128849818.8	257699637.6	12884981.88	25769963.76	128849818.8	257699637.6
93	139587137.0	279174274.0	13958713.70	27917427.40	139587137.0	279174274.0
94	150324455.3	300648910.6	15032445.53	30064891.06	150324455.3	300648910.6
95	161061773.5	322123547.0	16106177.35	32212354.70	161061773.5	322123547.0
96	171799091.8	343598183.6	17179909.18	34359818.36	171799091.8	343598183.6
97	182536410.0	365072820.0	18253641.00	36507282.00	182536410.0	365072820.0
98	193273728.2	386547456.4	19327372.82	38654745.64	193273728.2	386547456.4
99	204011046.5	408022093.0	20401104.65	40802209.30	204011046.5	408022093.0
100	429496729.5	429496729.5	42949672.95	42949672.95	429496729.5	429496729.5

5.4 Transmission Parameters Simulation values

The simulated values for Transmission parameters are listed in Table 5-19 to Table 5-22.

Table 5 – 19 Transmission Service \$01 PID (\$04 – \$11) Simulated Values at control steps 0 to 50

Trans.	\$04 / \$F404	\$05 / \$F405	\$0B / F40B	\$0C / \$F40C	\$0D / \$F40D	\$0F / \$F40F	\$11 / \$F411
Step	LOAD_PCT (%)	ECT(C)	MAP (kPa)	RPM(Min-1)	VSS (km/h)	IAT C)	TP (%)
0	0.00%	-40	0	0.00	0	-40	0.00%
1	0.78%	-39	2	50.00	2	-36	0.78%
2	1.96%	-37	5	100.00	5	-32	1.96%
3	2.75%	-36	7	150.00	7	-28	2.75%
4	3.92%	-34	10	200.00	10	-24	3.92%
5	4.71%	-33	12	250.00	12	-20	4.71%
6	5.88%	-31	15	300.00	15	-16	5.88%
7	6.67%	-30	17	350.00	17	-12	6.67%
8	7.84%	-28	20	400.00	20	-8	7.84%
9	8.63%	-27	22	450.00	22	-4	8.63%
10	9.80%	-25	25	500.00	25	0	9.80%
11	10.98%	-24	28	550.00	28	1	10.98%
12	11.76%	-22	30	600.00	30	2	11.76%
13	12.94%	-21	33	650.00	33	3	12.94%
14	13.73%	-19	35	700.00	35	4	13.73%
15	14.90%	-18	38	750.00	38	5	14.90%
16	15.69%	-16	40	800.00	40	6	15.69%
17	16.86%	-15	43	850.00	43	7	16.86%
18	17.65%	-13	45	900.00	45	8	17.65%
19	18.82%	-12	48	950.00	48	9	18.82%
20	20.00%	-10	51	1000.00	51	10	20.00%
21	20.78%	-9	53	1050.00	53	11	20.78%
22	21.96%	-7	56	1100.00	56	12	21.96%
23	22.75%	-6	58	1150.00	58	13	22.75%
24	23.92%	-4	61	1200.00	61	14	23.92%
25	24.71%	-3	63	1250.00	63	15	24.71%
26	25.88%	-1	66	1300.00	66	16	25.88%
27	26.67%	0	68	1350.00	68	17	26.67%
28	27.84%	2	71	1400.00	71	18	27.84%
29	28.63%	3	73	1450.00	73	19	28.63%
30	29.80%	5	76	1500.00	76	20	29.80%
31	30.98%	6	79	1550.00	79	21	30.98%
32	31.76%	8	81	1600.00	81	22	31.76%
33	32.94%	9	83	1650.00	84	23	32.94%
34	33.73%	11	86	1700.00	87	24	33.73%
35	34.90%	12	89	1750.00	89	25	34.90%
36	35.69%	14	91	1800.00	91	26	35.69%
37	36.86%	15	94	1850.00	94	27	36.86%
38	37.65%	17	96	1900.00	96	28	37.65%
39	38.82%	18	99	1950.00	99	29	38.82%
40	40.00%	20	102	2000.00	102	30	40.00%
41	40.78%	21	104	2050.00	104	31	40.78%
42	41.96%	23	107	2100.00	107	32	41.96%
43	42.75%	24	109	2150.00	109	33	42.75%
44	43.92%	26	112	2200.00	112	34	43.92%
45	44.71%	27	114	2250.00	114	35	44.71%
46	45.88%	29	117	2300.00	117	36	45.88%
47	46.67%	30	119	2350.00	119	37	46.67%
48	47.84%	32	122	2400.00	122	38	47.84%
49	48.63%	33	124	2450.00	124	39	48.63%
50	49.80%	35	127	2500.00	127	40	49.80%

Table 5 – 20 Transmission Service \$01 PID (\$04 – \$11) Simulated Values at control steps 51 to 100

Trans.	\$04 / \$F404	\$05 / \$F405	\$0B / \$F40B	\$0C / \$F40C	\$0D / \$F40D	\$0F / \$F40F	\$11 / \$F411
Step	LOAD_PCT (%)	ECT(C)	MAP (kPa)	RPM(Min-1)	VSS (km/h)	IAT C)	TP (%)
51	50.98%	36	130	2550.00	130	41	50.98%
52	51.76%	38	132	2600.00	132	42	51.76%
53	52.94%	39	135	2650.00	135	43	52.94%
54	53.73%	41	137	2700.00	137	44	53.73%
55	54.90%	42	140	2750.00	140	45	54.90%
56	55.69%	44	142	2800.00	142	46	55.69%
57	56.86%	45	145	2850.00	145	47	56.86%
58	57.65%	47	147	2900.00	147	48	57.65%
59	58.82%	48	150	2950.00	150	49	58.82%
60	60.00%	50	153	3000.00	153	50	60.00%
61	60.78%	51	155	3050.00	155	51	60.78%
62	61.96%	53	158	3100.00	158	52	61.96%
63	62.75%	54	160	3150.00	160	53	62.75%
64	63.92%	56	163	3200.00	163	54	63.92%
65	64.71%	57	165	3250.00	165	55	64.71%
66	65.88%	59	168	3300.00	168	56	65.88%
67	66.67%	60	170	3350.00	170	57	66.67%
68	67.84%	62	173	3400.00	173	58	67.84%
69	68.63%	63	175	3450.00	175	59	68.63%
70	69.80%	65	178	3500.00	178	60	69.80%
71	70.98%	66	181	3550.00	181	61	70.98%
72	71.76%	68	183	3600.00	183	62	71.76%
73	72.94%	69	186	3650.00	186	63	72.94%
74	73.73%	71	188	3700.00	188	64	73.73%
75	74.90%	72	191	3750.00	191	65	74.90%
76	75.69%	74	193	3800.00	193	66	75.69%
77	76.86%	75	196	3850.00	196	67	76.86%
78	77.65%	77	198	3900.00	198	68	77.65%
79	78.82%	78	201	3950.00	201	69	78.82%
80	80.00%	80	204	4000.00	204	70	80.00%
81	80.78%	86	206	4619.00	206	76	80.78%
82	81.96%	93	209	5238.25	209	82	81.96%
83	82.75%	100	211	5857.50	211	88	82.75%
84	83.92%	107	214	6476.75	214	94	83.92%
85	84.71%	113	216	7095.75	216	100	84.71%
86	85.88%	120	219	7715.00	219	106	85.88%
87	86.67%	127	221	8334.25	221	112	86.67%
88	87.84%	134	224	8953.50	224	118	87.84%
89	88.63%	140	226	9572.75	226	124	88.63%
90	89.80%	147	229	10191.75	229	130	89.80%
91	90.98%	154	232	10811.00	232	138	90.98%
92	91.76%	161	234	11430.25	234	147	91.76%
93	92.94%	167	237	12049.25	237	155	92.94%
94	93.73%	174	239	12668.50	239	164	93.73%
95	94.90%	181	242	13287.75	242	172	94.90%
96	95.69%	188	244	13907.00	244	181	95.69%
97	96.86%	194	247	14526.00	247	189	96.86%
98	97.65%	201	249	15145.25	249	198	97.65%
99	98.82%	208	252	15764.50	252	206	98.82%
100	100.00%	215	255	16383.75	255	215	100.00%

Table 5 – 21 Transmission Service \$01 PID (\$1F – 4A) Simulated Values at control steps 0 to 50

Trans.	\$1F / \$F41F	\$21 / \$F421	\$31 / \$F431	\$33 / \$F433	\$42 / \$F442	\$45 /47 / \$F445/F447	\$49 /4A / \$F449/F449
Step	RUNTM (sec)	MIL_DIST (km)	CLR_DIST (km)	BARO	VPWR (v)	TP_R/TP_B	APP_D/APP_E
0	0	0	0	0	0.000	0.00%	0.00%
1	655	655	655	2	0.400	0.78%	0.78%
2	1310	1310	1310	5	0.800	1.96%	1.96%
3	1966	1966	1966	7	1.200	2.75%	2.75%
4	2621	2621	2621	10	1.600	3.92%	3.92%
5	3276	3276	3276	12	2.000	4.71%	4.71%
6	3932	3932	3932	15	2.400	5.88%	5.88%
7	4587	4587	4587	17	2.800	6.67%	6.67%
8	5242	5242	5242	20	3.200	7.84%	7.84%
9	5898	5898	5898	22	3.600	8.63%	8.63%
10	6553	6553	6553	25	4.000	9.80%	9.80%
11	7208	7208	7208	28	4.400	10.98%	10.98%
12	7864	7864	7864	30	4.800	11.76%	11.76%
13	8519	8519	8519	33	5.200	12.94%	12.94%
14	9174	9174	9174	35	5.600	13.73%	13.73%
15	9830	9830	9830	38	6.000	14.90%	14.90%
16	10485	10485	10485	40	6.400	15.69%	15.69%
17	11140	11140	11140	43	6.800	16.86%	16.86%
18	11796	11796	11796	45	7.200	17.65%	17.65%
19	12451	12451	12451	48	7.600	18.82%	18.82%
20	13107	13107	13107	51	8.000	20.00%	20.00%
21	13762	13762	13762	53	8.400	20.78%	20.78%
22	14417	14417	14417	56	8.800	21.96%	21.96%
23	15073	15073	15073	58	9.200	22.75%	22.75%
24	15728	15728	15728	61	9.600	23.92%	23.92%
25	16383	16383	16383	63	10.000	24.71%	24.71%
26	17039	17039	17039	66	10.400	25.88%	25.88%
27	17694	17694	17694	68	10.800	26.67%	26.67%
28	18349	18349	18349	71	11.200	27.84%	27.84%
29	19005	19005	19005	73	11.600	28.63%	28.63%
30	19660	19660	19660	76	12.000	29.80%	29.80%
31	20315	20315	20315	79	12.400	30.98%	30.98%
32	20971	20971	20971	81	12.800	31.76%	31.76%
33	21626	21626	21626	84	13.200	32.94%	32.94%
34	22281	22281	22281	86	13.600	33.73%	33.73%
35	22937	22937	22937	89	14.000	34.90%	34.90%
36	23592	23592	23592	91	14.400	35.69%	35.69%
37	24247	24247	24247	94	14.800	36.86%	36.86%
38	24903	24903	24903	96	15.200	37.65%	37.65%
39	25558	25558	25558	99	15.600	38.82%	38.82%
40	26214	26214	26214	102	16.000	40.00%	40.00%
41	26869	26869	26869	104	16.400	40.78%	40.78%
42	27524	27524	27524	107	16.800	41.96%	41.96%
43	28180	28180	28180	109	17.200	42.75%	42.75%
44	28835	28835	28835	112	17.600	43.92%	43.92%
45	29490	29490	29490	114	18.000	44.71%	44.71%
46	30146	30146	30146	117	18.400	45.88%	45.88%
47	30801	30801	30801	119	18.800	46.67%	46.67%
48	31456	31456	31456	122	19.200	47.84%	47.84%
49	32112	32112	32112	124	19.600	48.63%	48.63%
50	32767	32767	32767	127	20.000	49.80%	49.80%

Table 5 – 22 Transmission Service \$01 PID (\$1F - 4A) Simulated Values at control steps 51 to 100

Step	\$1F / \$F41F	\$21 / \$F421	\$31 / \$F431	\$33 / \$F433	\$42 / \$F442	\$45/47 / \$F445/F447	\$49/4A / \$F449/4A
	RUNTM (sec)	MIL_DIST(km)	CLR_DIST(km)	BARO	VPWR	TP_R/TP_B	APP_D/ APP_E
51	33422	33422	33422	130	20.400	50.98%	50.98%
52	34078	34078	34078	132	20.800	51.76%	51.76%
53	34733	34733	34733	135	21.200	52.94%	52.94%
54	35388	35388	35388	137	21.600	53.73%	53.73%
55	36044	36044	36044	140	22.000	54.90%	54.90%
56	36699	36699	36699	142	22.400	55.69%	55.69%
57	37354	37354	37354	145	22.800	56.86%	56.86%
58	38010	38010	38010	147	23.200	57.65%	57.65%
59	38665	38665	38665	150	23.600	58.82%	58.82%
60	39320	39320	39321	153	24.000	60.00%	60.00%
61	39976	39976	39976	155	24.400	60.78%	60.78%
62	40631	40631	40631	158	24.800	61.96%	61.96%
63	41287	41287	41287	160	25.200	62.75%	62.75%
64	41942	41942	41942	163	25.600	63.92%	63.92%
65	42597	42597	42597	165	26.000	64.71%	64.71%
66	43253	43253	43253	168	26.400	65.88%	65.88%
67	43908	43908	43908	170	26.800	66.67%	66.67%
68	44563	44563	44563	173	27.200	67.84%	67.84%
69	45219	45219	45219	175	27.600	68.63%	68.63%
70	45874	45874	45874	178	28.000	69.80%	69.80%
71	46529	46529	46529	181	28.400	70.98%	70.98%
72	47185	47185	47185	183	28.800	71.76%	71.76%
73	47840	47840	47840	186	29.200	72.94%	72.94%
74	48495	48495	48495	188	29.600	73.73%	73.73%
75	49151	49151	49151	191	30.000	74.90%	74.90%
76	49806	49806	49806	193	30.400	75.69%	75.69%
77	50461	50461	50461	196	30.800	76.86%	76.86%
78	51117	51117	51117	198	31.200	77.65%	77.65%
79	51772	51772	51772	201	31.600	78.82%	78.82%
80	52428	52428	52428	204	32.000	80.00%	80.00%
81	53083	53083	53083	206	33.676	80.78%	80.78%
82	53738	53738	53738	209	35.353	81.96%	81.96%
83	54394	54394	54394	211	37.030	82.75%	82.75%
84	55049	55049	55049	214	38.707	83.92%	83.92%
85	55704	55704	55704	216	40.383	84.71%	84.71%
86	56360	56360	56360	219	42.060	85.88%	85.88%
87	57015	57015	57015	221	43.737	86.67%	86.67%
88	57670	57670	57670	224	45.414	87.84%	87.84%
89	58326	58326	58326	226	47.090	88.63%	88.63%
90	58981	58981	58981	229	48.767	89.80%	89.80%
91	59636	59636	59636	232	50.444	90.98%	90.98%
92	60292	60292	60292	234	52.121	91.76%	91.76%
93	60947	60947	60947	237	53.797	92.94%	92.94%
94	61602	61602	61602	239	55.474	93.73%	93.73%
95	62258	62258	62258	242	57.151	94.90%	94.90%
96	62913	62913	62913	244	58.828	95.69%	95.69%
97	63568	63568	63568	247	60.504	96.86%	96.86%
98	64224	64224	64224	249	62.181	97.65%	97.65%
99	64879	64879	64879	252	63.858	98.82%	98.82%
100	65535	65535	65535	255	65.535	100.00%	100.00%

5.5 ABS Parameters Simulation values

The simulated values for ABS parameters are listed in Table 5-23 to Table 5-24.

Table 5 – 23 ABS Service \$01 PID Simulated Value at control steps 0 to 50

ABS	\$0D / \$F40D	\$1C / \$F41C	\$90 / \$F490	\$91 / \$F491	\$91 / \$F491
Step	VSS (km/h)	OBD requirements for vehicle or engine	WWH-OBD Vehicle OBD System Information	WWH-OBD ECU OBD System Information	WWH-OBD ECU OBD System Information
0	0	\$01	0	0	0
1	2	\$02	655	655	655
2	5	\$03	1310	1310	1310
3	7	\$04	1966	1966	1966
4	10	\$05	2621	2621	2621
5	12	\$06	3276	3276	3276
6	15	\$07	3932	3932	3932
7	17	\$08	4587	4587	4587
8	20	\$09	5242	5242	5242
9	22	\$0A	5898	5898	5898
10	25	\$0B	6553	6553	6553
11	28	\$0C	7208	7208	7208
12	30	\$0D	7864	7864	7864
13	33	\$0E	8519	8519	8519
14	35	\$0F	9174	9174	9174
15	38	\$10	9830	9830	9830
16	40	\$11	10485	10485	10485
17	43	\$12	11140	11140	11140
18	45	\$13	11796	11796	11796
19	48	\$14	12451	12451	12451
20	51	\$15	13107	13107	13107
21	53	\$16	13762	13762	13762
22	56	\$17	14417	14417	14417
23	58	\$18	15073	15073	15073
24	61	\$19	15728	15728	15728
25	63	\$1A	16383	16383	16383
26	66	\$1B	17039	17039	17039
27	68	\$1C	17694	17694	17694
28	71	\$1D	18349	18349	18349
29	73	\$1E	19005	19005	19005
30	76	\$1F	19660	19660	19660
31	79	\$20	20315	20315	20315
32	81	\$21	20971	20971	20971
33	84	\$22	21626	21626	21626
34	87	\$23	22281	22281	22281
35	89	\$24	22937	22937	22937
36	91	\$25	23592	23592	23592
37	94	\$26	24247	24247	24247
38	96	\$27	24903	24903	24903
39	99	\$28	25558	25558	25558
40	102	\$29	26214	26214	26214
41	104	\$2A	26869	26869	26869
42	107	\$2B	27524	27524	27524
43	109	\$2C	28180	28180	28180
44	112	\$2D	28835	28835	28835
45	114	\$2E	29490	29490	29490
46	117	\$2F	30146	30146	30146
47	119	\$30	30801	30801	30801
48	122	\$31	31456	31456	31456
49	124	\$09	32112	32112	32112
50	127	\$09	32767	32767	32767

Table 5 – 24 ABS Service \$01 PIDs Simulated Values at control steps 51 to 100

ABS	\$0D / \$F40D	\$1C / \$F41C	\$90 / \$F490	\$91 / \$F491	\$91 / \$F491
Step	VSS (km/h)	OBd requirements for vehicle or engine	WWH-OBd Vehicle OBd System Information	WWH-OBd ECU OBd System Information	WWH-OBd ECU OBd System Information
51	130	\$09	33422	33422	33422
52	132	\$09	34078	34078	34078
53	135	\$09	34733	34733	34733
54	137	\$09	35388	35388	35388
55	140	\$09	36044	36044	36044
56	142	\$09	36699	36699	36699
57	145	\$09	37354	37354	37354
58	147	\$09	38010	38010	38010
59	150	\$09	38665	38665	38665
60	153	\$09	39320	39320	39320
61	155	\$09	39976	39976	39976
62	158	\$09	40631	40631	40631
63	160	\$09	41287	41287	41287
64	163	\$09	41942	41942	41942
65	165	\$09	42597	42597	42597
66	168	\$09	43253	43253	43253
67	170	\$09	43908	43908	43908
68	173	\$09	44563	44563	44563
69	175	\$09	45219	45219	45219
70	178	\$09	45874	45874	45874
71	181	\$09	46529	46529	46529
72	183	\$09	47185	47185	47185
73	186	\$09	47840	47840	47840
74	188	\$09	48495	48495	48495
75	191	\$09	49151	49151	49151
76	193	\$09	49806	49806	49806
77	196	\$09	50461	50461	50461
78	198	\$09	51117	51117	51117
79	201	\$09	51772	51772	51772
80	204	\$09	52428	52428	52428
81	206	\$09	53083	53083	53083
82	209	\$09	53738	53738	53738
83	211	\$09	54394	54394	54394
84	214	\$09	55049	55049	55049
85	216	\$09	55704	55704	55704
86	219	\$09	56360	56360	56360
87	221	\$09	57015	57015	57015
88	224	\$09	57670	57670	57670
89	226	\$09	58326	58326	58326
90	229	\$09	58981	58981	58981
91	232	\$09	59636	59636	59636
92	234	\$09	60292	60292	60292
93	237	\$09	60947	60947	60947
94	239	\$09	61602	61602	61602
95	242	\$09	62258	62258	62258
96	244	\$09	62913	62913	62913
97	247	\$09	63568	63568	63568
98	249	\$09	64224	64224	64224
99	252	\$09	64879	64879	64879
100	255	\$09	65535	65535	65535

Chapter - 6 Appendix

6.1 Appendix A - Remote Terminal GUI Installation Guide

Au remote terminal GUI is an application designed for the Windows operating system. It can be used to control and display simulated SAE OBD2 CAN parameters on a PC screen. It can also be used for license upgrading if needed.

6.1.1 What is needed?

- PC software: Au "setup OBD2 CAN Simulator Remote Terminal V1.00A Build 07262023-01" can be downloaded from the link at: https://www.auelectronics.com/downloads/software/software_simobd2can.zip
- A PC equipped with a serial port, and a serial extension cable, or a PC equipped with a USB port, and a "USB to serial convert cable".

6.1.2 Step by step installation guide

Double click the "setup OBD2 CAN Simulator Remote Terminal V1.00A" installation file.

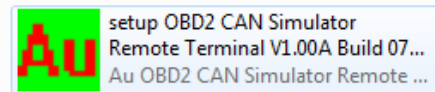

"License Agreement" window pop up, please read the license agreement and select "I accept the agreement", click "Next" to continue.

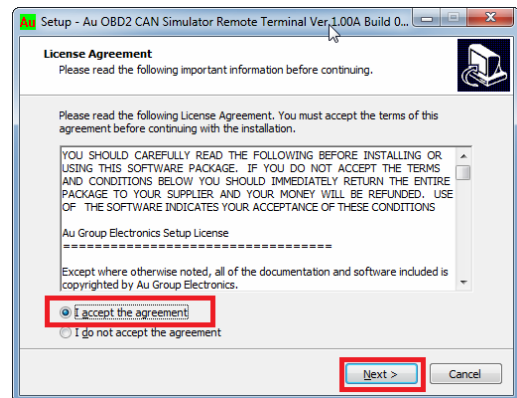

"Select Destination Location" window pop up, use the default folder, and click "Next" to continue

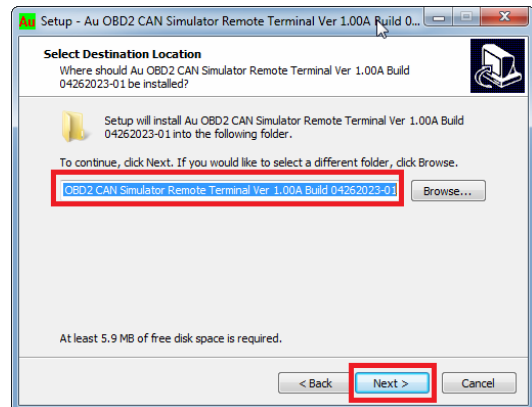

“Select Start Menu Folder” window pop up, use the default folder and click “Next” to continue

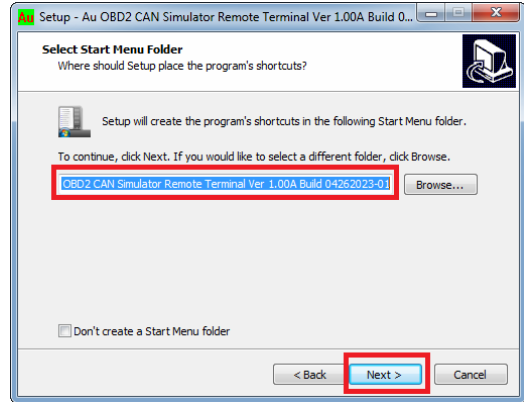

“Select Additional Tasks” window pop up, check both “Create a desktop” icon, and “Create a Quick Launch” icon”. click “Next” to continue.

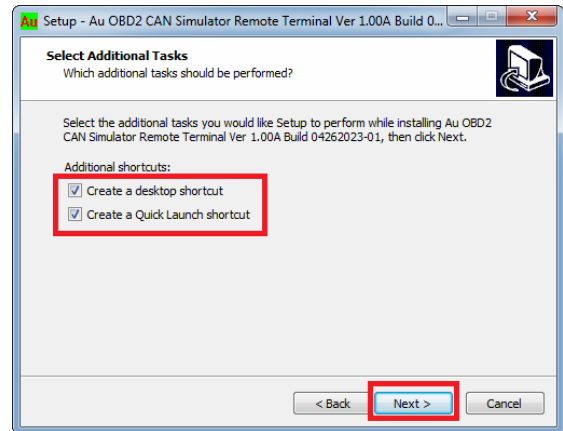

“Ready to Install” window pop up, click “Install”.

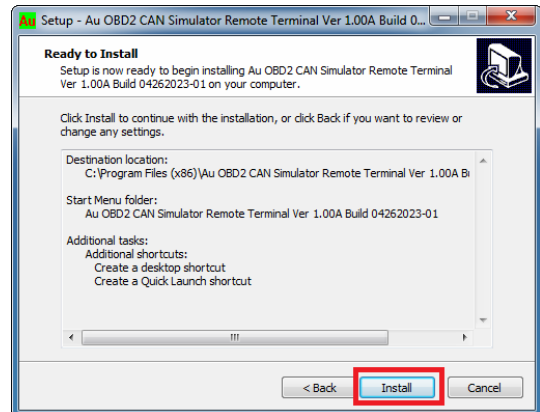

Check "Launch Au OBD2 CAN Simulator Remote Terminal ...", then click "Finish".

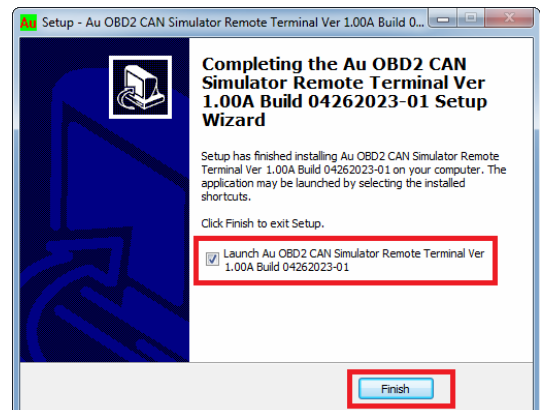

6.2 Appendix B - How to upgrade Au OBD2 CAN Simulator License

Upgrading Au OBD2 CAN Simulator license can be done in-field in a few seconds, provided that the OBD2 CAN Simulator device is powered up, connected with a PC, and license upgrade code is ready.

6.2.1 What is needed?

1. Order license upgrade code from the following web link: <https://www.auelectronics.com/System-SIMOB2CAN.htm> (Please refer to Figure 1-7 or Table 1-3 to find out which code to be ordered.)
2. A PC equipped with serial port and a RS232 serial extension cable (Item # CBL-RS232-01) or a PC equipped with USB port and a "USB to serial converter cable" (Item #: CBL-USB-232).
3. Au OBD2 CAN Simulator.
4. Au OBD2 CAN Simulator Remote Terminal GUI. (Refer to Appendix A for how to install)

6.2.2 Step by Step License Upgrading Procedure

Connect your PC with Au OBD2 CAN Simulator, and power up Au OBD2 CAN Simulator using an AC/DC power supply (part # PWR-912V-CP).

Launch Au OBD2 CAN Simulator Remote Terminal program, select the serial communication port that was used to connect OBD2 CAN Simulator(e.g. COM1), then click "Connect" button. Notice the Product ID shows "Value Package" (Figure B-1)

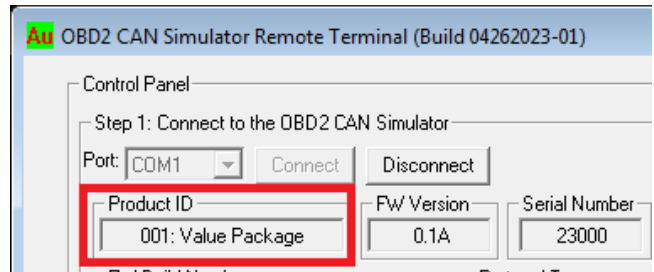

Figure B - 1

Click the Au Logo on the top left corner of Au OBD2 CAN Simulator Remote Terminal, then click "About OBD2 CAN SimulatorRemoteTerminal ..." as shown in Figure B - 2.

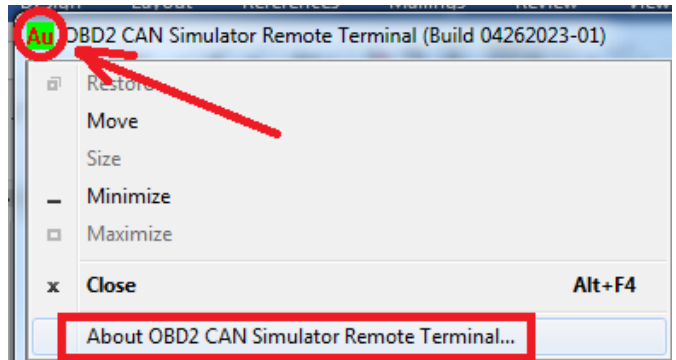

Figure B - 2

"About Au OBD2 CAN Simulator" window will pop up (Figure B-3). Enter a valid license code, and then click "Validate license" button to continue.

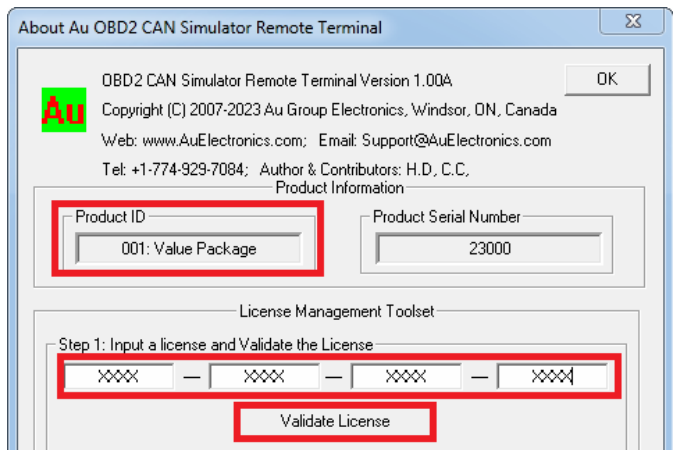

Figure B - 3

Each Au OBD2 CAN Simulator has a unique Serial Number. If the license code is invalid, an error message will pop up, as shown in Figure B - 4 and Figure B - 5.

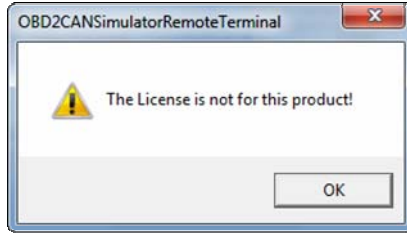

Figure B – 4

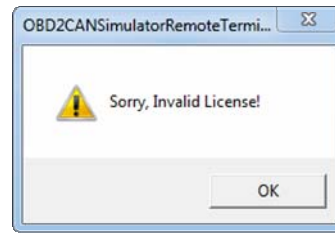

Figure B - 5

After a valid license is entered, updated license Information will be displayed, as demonstrated here in Figure B-6. OBD2 CAN Simulator Value Package edition will be upgraded to vehicle Platinum Script Edition. Click “Update License” button.

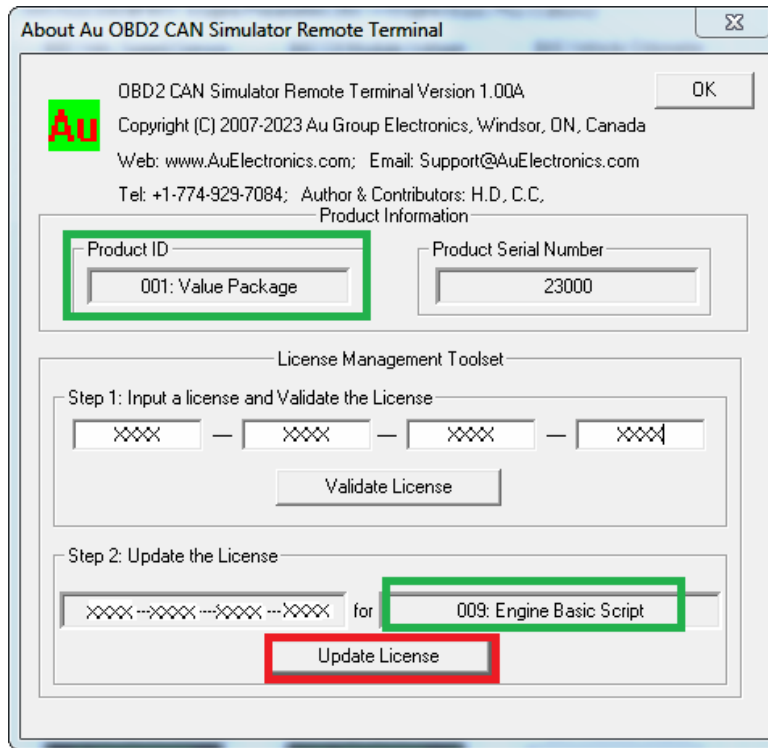

Figure B - 6

When it is updated successfully, a beep will be heard. “About OBD2 CAN Simulator” window will close automatically, and the Product ID (Edition of OBD2 CAN Simulator) will update to the new edition (Vehicle Platinum Scrip edition in this demonstration, as shown in Figure B-7).

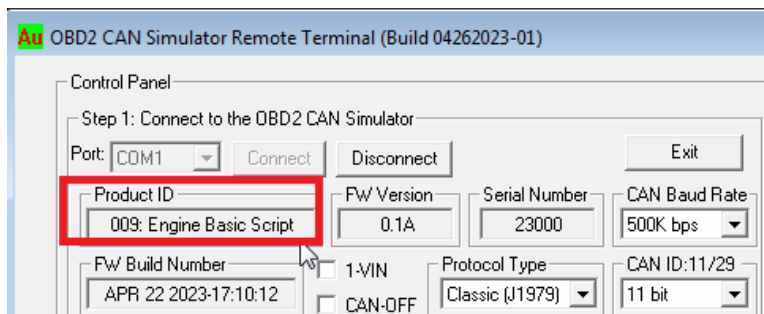

Figure B - 7

6.3 Appendix C - How to install Au PIC Boot-loader

1. Double click icon of the “Setup Au PIC Boot-loader V1.00B” to start installing Au PIC Boot-loader (Figure C-1).

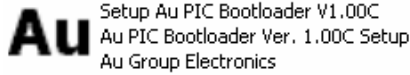

Figure C-1 Setup Au PIC Boot-loader V1.00A icon

2. “Welcome to the Au PIC Boot-loader Setup Wizard” window will show up, click “Next” (Figure C- 2)

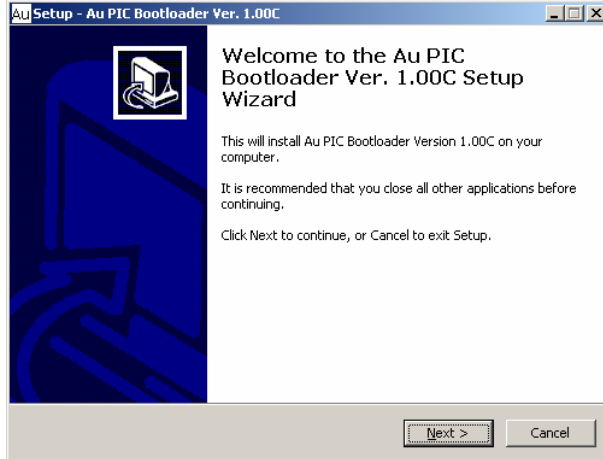

Figure C-2

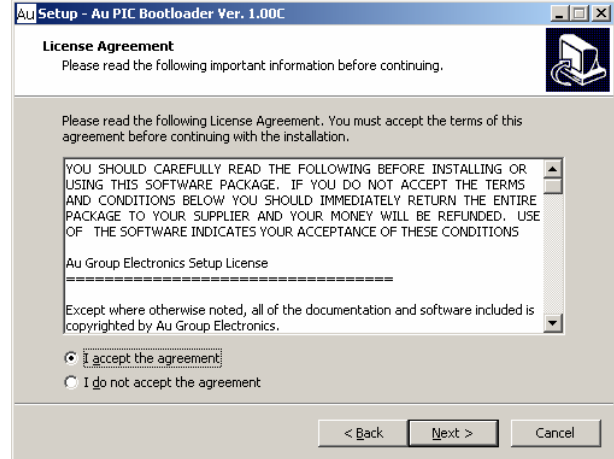

Figure C-3

3. “License Agreement” window will show up. Read the license agreement and select “I accept the agreement”, then click “Next” to continue (Figure C-3).
4. “Select Destination” window shows up, use default path: C:\Program Files\ AU PIC Boot-loader”, then click “next” to continue (Figure C-4).

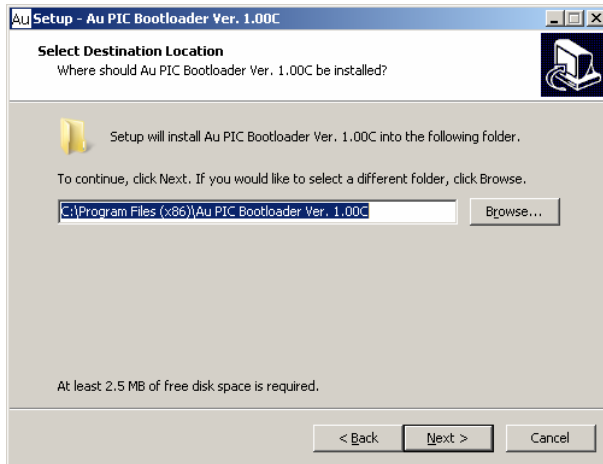

Figure C-4

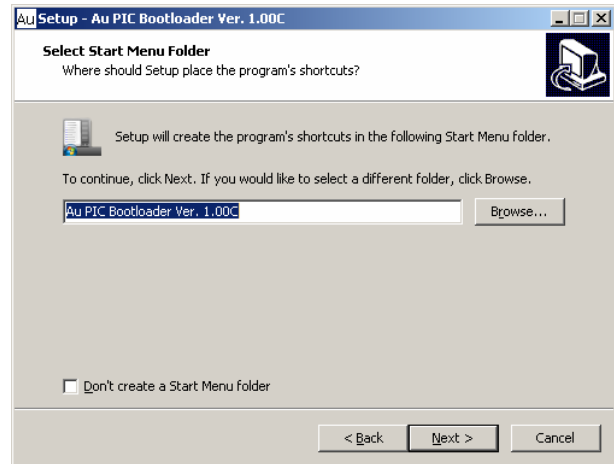

Figure C-5

5. “Select Start Menu Folder” window will show up. Use default setting “AU PIC Boot-loader”, then click “next” (Figure C-5).
6. “Select Additional Task” window shows up, check both “create a desktop icon” and “Create a quick launch icon”, and then click “next” to continue (Figure C-6).

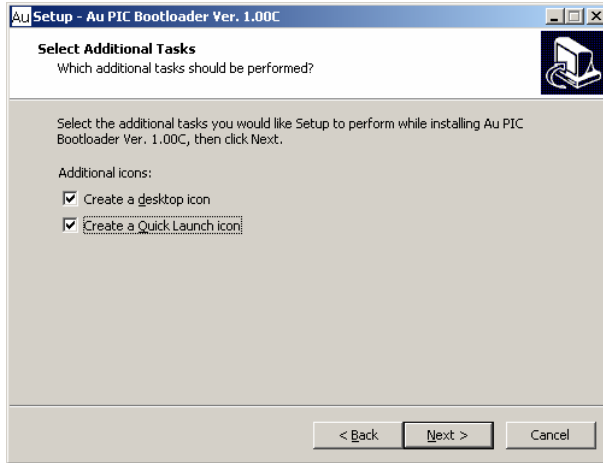

Figure C-6

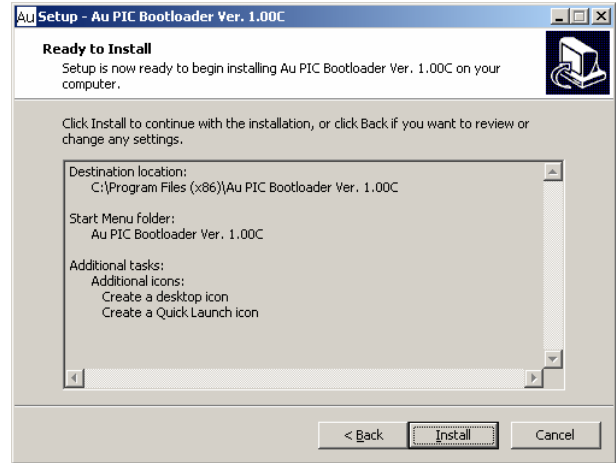

Figure C-7

7. "Ready to Install" window shows up. Click "Install" (Figure C-7).
8. After a few seconds, "Completing the Au PIC Boot-loader Setup Wizard" window shows up. Check "launch Au Boot-loader", and click "Finish" to exit setup (FigureC-8).

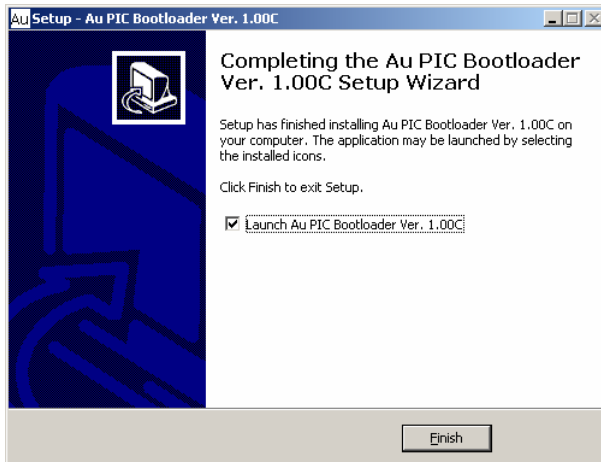

Figure C-8

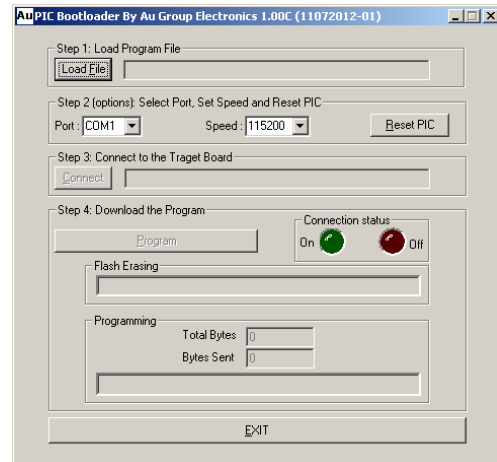

Figure C-9

9. Au PIC18 Boot-loader is launched, as shown in Figure C-9

Thank You

Thank you for choosing Au Group Electronics products.

Should you have any question or comments, please contact us at:
support@AuElectronics.com

We look forward to serving you again in the near future.