

Au NMEA 2000 PowerTrain Simulator User Manual

Rev. B

Au Group Electronics

August 2020

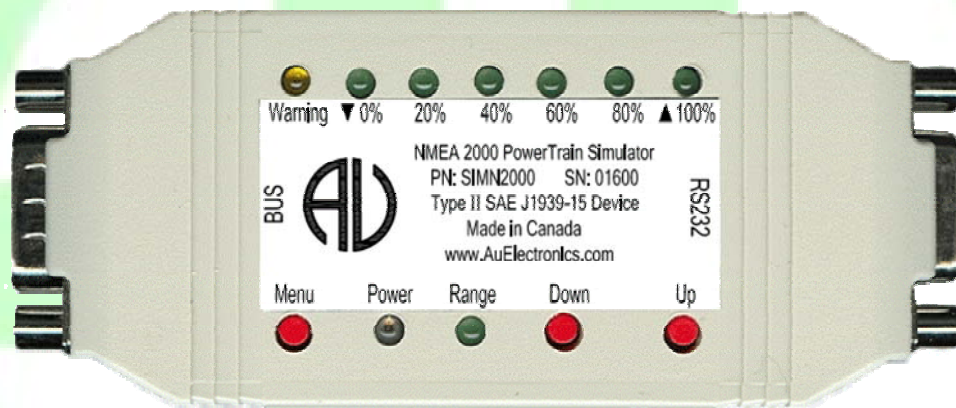

All copyrights are reserved by Au Group Electronics.

This document can **NOT** be freely distributed without written approval from Au Group Electronics.



Table of Contents

- Table of Contents 2
- Chapter 1 Introduction 3
 - 1.1. NMEA 2000 Network Topology with Au NMEA 2000 PowerTrain Simulator 3
 - 1.2. Eight Editions of Au NMEA 2000 PowerTrain Simulators 3
 - 1.3. Major Hardware Features 4
 - 1.4. Major Operating Features 5
 - 1.5. Basic Functions of Each Edition 6
 - 1.6. License /Software Code Upgrade and Support Service 6
- Chapter 2 Supported NMEA 2000 Parameters 7
 - 2.1. Value Package Edition(S) 7
 - 2.2. Engine Basic Edition(S) 7
 - 2.3. Engine Premium Edition(S) 7
 - 2.4. Vessel Platinum Edition(S) 7
- Chapter 3 Operating Instructions 8
 - 3.1. Power On 8
 - 3.2. Operating Modes (Static/Dynamic) 8
 - 3.3. Push Button Functions 8
 - 3.4. LED Indicator Status 9
- Chapter 4 Au NMEA 2000 PowerTrain Simulator Remote Terminal 13
 - 4.1. Connect To AU NMEA 2000 PowerTrain Simulator 13
 - 4.2. Remote Control Au NMEA 2000 PowerTrain Simulator 14
 - 4.3. NMEA 2000 Source Address Status 15
 - 4.4. NMEA 2000 Device Instance & Sequence ID (SID) 15
 - 4.5. 6 Engine Parameters for Value Package Edition 17
 - 4.6. 20 Engine Basic Parameters 17
 - 4.7. Engine Discrete Statuses for Engine Premium Edition 17
 - 4.8. 21 Vessel Parameters for Vessel Platinum Edition 18
- Chapter 5 Data Configuration 19
 - 5.1. Simulation Data for SIMN2000 Value Package Edition 20
 - 5.2. Simulation Data for SIMN2000 Engine Basic Edition 22
 - 5.3. Simulation Data for SIMN2000 Engine Premium Edition 33
 - 5.4. Simulation Data for SIMN2000 Vessel Platinum Edition 34

Chapter 1 Introduction

Au NMEA 2000 PowerTrain Simulator (Figure 1-1), a family of well designed devices, are capable of simulating majority of NMEA 2000 PowerTrain signals on a NMEA 2000 network. They can be connected to NMEA 2000 network at the 9 pin "BUS" connector. The pin out of the DB9 male "BUS" interface is illustrated in Figure 1-2.

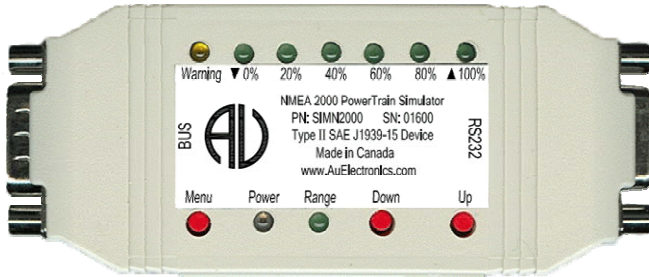

Figure 1-1 Au NMEA 2000 PowerTrain Simulator

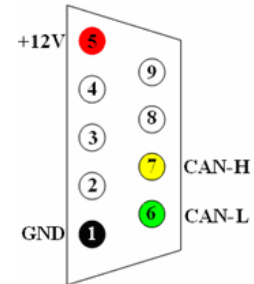

Figure 1-2 BUS Side DB9 male connector

1.1. NMEA 2000 Network Topology with Au NMEA 2000 PowerTrain Simulator

A typical NMEA 2000 network topology with Au NMEA 2000 PowerTrain Simulator is illustrated in Figure 1-3.

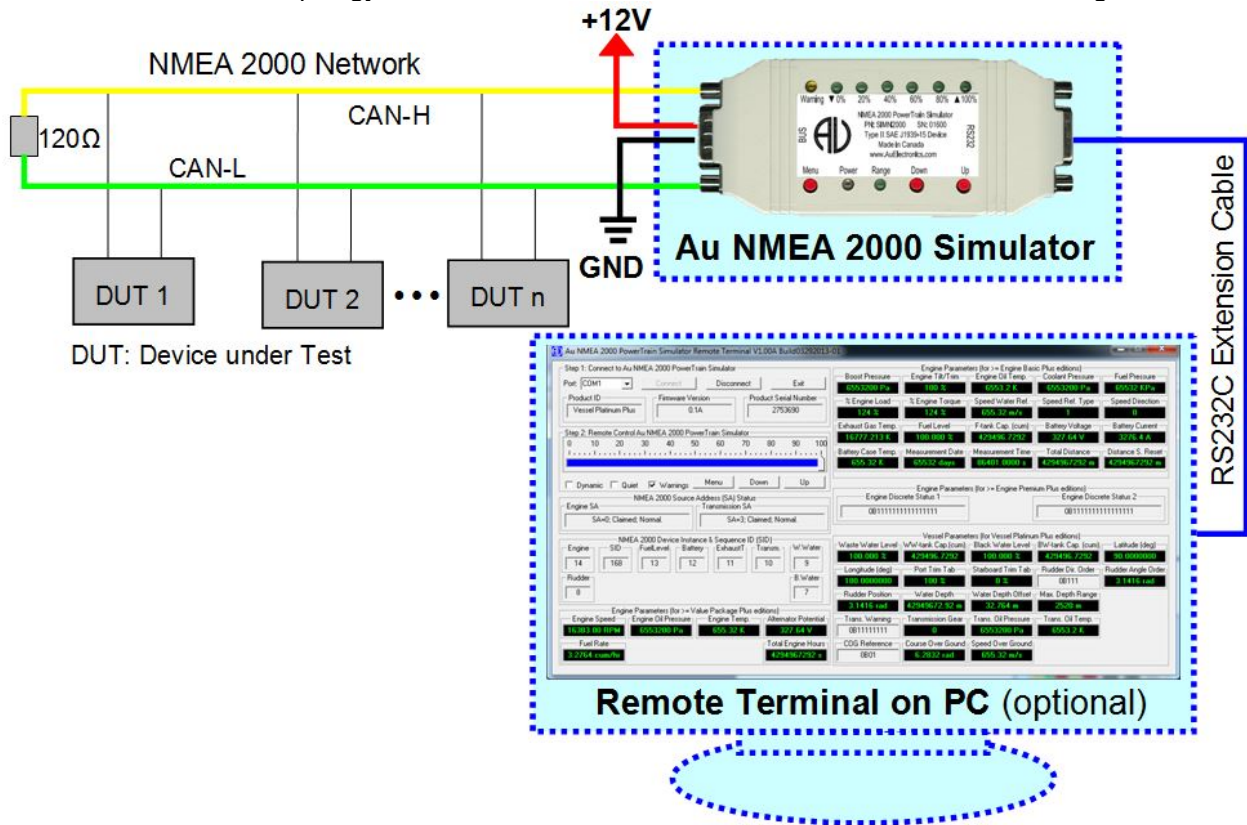

Figure 1-3 Typical NMEA 2000 network topology for Au NMEA 2000 PowerTrain Simulator(s)

1.2. Eight Editions of Au NMEA 2000 PowerTrain Simulators

Eight editions of Au NMEA 2000 PowerTrain simulators are provided to meet various users' needs (4 non-plus editions and 4 plus editions). The **Plus** editions have all the functions of **non-Plus** editions, plus a **PC Remote Terminal** program, which can be used to control and display detail information of simulated NMEA 2000 signals on a PC screen (detail information is available in chapter 4.)

Plus Edition = Non-plus Edition + PC Remote Terminal SW + Device Instance management

This document will introduce major hardware features, important parameters, operating instruction, remote terminal program and data configuration for all 8 editions of Au NMEA 2000 PowerTrain Simulators.



The part # for 8 editions of Au NMEA 2000 PowerTrain simulators and necessary accessories are listed in Table 1-1

Table 1-1 Part # for Au NMEA 2000 PowerTrain simulator and necessary accessories

Au NMEA 2000 Simulator, Accessories, and Service		Part #
Non-Plus Edition	Au NMEA 2000 PowerTrain Simulator Value Package Non-Plus Edition	SIMN2000-001
	Au NMEA 2000 PowerTrain Simulator Engine Basic Non-Plus Edition	SIMN2000-002
	Au NMEA 2000 PowerTrain Simulator Engine Premium Non-Plus Edition	SIMN2000-003
	Au NMEA 2000 PowerTrain Simulator Vessel Platinum Non-Plus Edition	SIMN2000-004
Plus Edition	Au NMEA 2000 PowerTrain Simulator Value Package Plus Edition	SIMN2000-005
	Au NMEA 2000 PowerTrain Simulator Engine Basic Plus Edition	SIMN2000-006
	Au NMEA 2000 PowerTrain Simulator Engine Premium Plus Edition	SIMN2000-007
	Au NMEA 2000 PowerTrain Simulator Vessel Platinum Plus Edition	SIMN2000-008
Accessories	RS232 Serial Extension Cable	CBL-RS232-01
	4-wire cable for power supply and CAN network connection	CBL-CAN-01
	USB to RS232 Serial Converter Cable (DB9-Male /Thumbscrew)	CBL-USB-232
Service	1 year support and minor upgrades for Au NMEA 2000 PowerTrain Simulator	SVS-SIM-N2000

1.3. Major Hardware Features

Major hardware features of Au NMEA 2000 PowerTrain Simulator are listed below:

- **SAE J1939-15 Type II ECU:** contains an internal 120 ohm load resistor for easy network setup
- **TVS (Transient Voltage Suppressor)** protection on CAN bus
- **Compact size:** 4-1/8" L X 1-3/4"W X 7/8"H
- **Enclosure color:** Black or PC white
- **Operating temperature:** -4 °F to 185 °F (-20 °C to 85 °C)
- **Power supply:** +12V~+28V DC, 250mA max
- **9 LED indicators:** Power, Range, Warning, ▼0%, 20%, 40%, 60%, 80%, ▲100%
- **1 buzzer**
- **3 push buttons:** The NMEA 2000 simulated signal can be adjusted by push buttons: Menu, Down, Up
- **1 DB9 Male "BUS" Interface** (Figure 1-2):

A four-wire cable (Au Part#: CBL-CAN-01, order separately) can be used for power supply and NMEA 2000 network connection. One end of the cable "CBL-CAN-01" is a DB9 connector which will mate with the "BUS" connector on the simulator. The other end of the cable consists of pigtail wires which can connect power supply and CAN network. The color definition of each wire of the cable is illustrated in Table 1-2.

Table 1-2 Color definition of the 4-wire cable (CBL-CAN-01, order separately)

Color	Signal
Red	+12 V power supply
White	CAN-H
Green	CAN-L
Black	Ground

- **1 RS232 interface:**

It is used for in field firmware update, license management and computer remote control (Plus editions only). Au NMEA 2000 PowerTrain Simulator Plus editions can be connected to the RS232 (serial) port of a PC, either through a RS232 serial extension cable (Part#: CBL-RS232-01, order separately), as shown in Figure 1-4; or through USB to RS232 Serial extension cable (DB9-Male /Thumbscrew (Part #: CBL-USB-232), as shown in figure 1-5. Please refer chapter 4 for detail information on Remote Terminal Program.

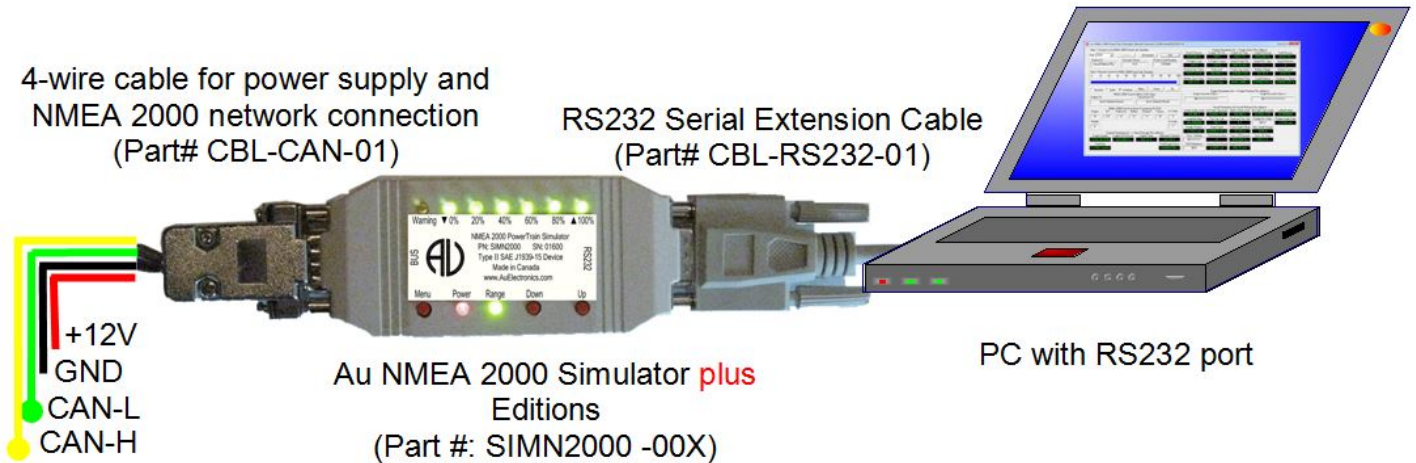

Figure 1-4 Connection of Au NMEA 2000 Simulator **plus** editions to PC with RS232 port



Figure 1-5 Connection of Au NMEA 2000 Simulator **plus** editions to PC with USB port

1.4. Major Operating Features

- **Smart features:** Recall last operating mode at power-on, capable of generating dynamic data, etc.
- **Ease of use:** Easy-to-operate design with production line operator and sales person in mind. No software setup experience or NMEA 2000 protocol configuration skill is required. After a network is physically connected, it will dynamically generate NMEA 2000 data when it enters dynamic mode.
- **Static mode and dynamic mode:**
 - Static mode output static NMEA 2000 signal. In this mode, signal can be changed manually
 - Dynamic mode automatically changes the output value of NMEA 2000 signal
 - Two modes can be switched easily
- **"Remote Terminal" software available** ("Plus" editions only): Display simulated NMEA 2000 signal on a computer screen.
- **All push button control functions are available on PC "Remote Terminal" software** ("Plus" editions only)
- **Easy in-field license upgrade feature** with Au License Management Tool. The Value Package Edition(s), Basic Edition(s) and Premium Edition(s) can be easily upgraded to Platinum Edition(s)
- **In-field firmware update capability** for minor upgrades (SVS-SIMN2000) and major upgrades (FIRN2000-00x)
- **Annual support and minor upgrade services** are available (SVS-SIMN2000)
- **Major firmware upgrade capability available** (FIRN2000-00x)
- **Custom design for more parameters is available upon request**

1.5. Basic Functions of Each Edition

Value Package Edition(s):

- NMEA 2000 Source Address status
- NMEA 2000 Device Instance and Sequence ID (SID)
- "Statically" or "dynamically" generate 6 engine parameters
- Push buttons (**Up & Down**) are used in "static mode" to adjust data outputs
- In "dynamic mode", data cycles automatically in NMEA 2000 defined range
- LEDs indicate the control step value and reflect push button operations
- Buzzer sound also reflects push button inputs, and can be enabled/disabled

Engine Basic Edition(s):

- Includes all Value Package Edition functions
- Plus 20 more engine basic parameters

Engine Premium Edition(s):

- Includes all Engine Basic Edition functions
- Plus warnings for Engine Discrete Status 1 and Engine Discrete Status 2

Vessel Platinum Edition(s):

- Includes all Engine Premium Edition functions
- Plus 21 Vessel parameters:

1.6. License /Software Code Upgrade and Support Service

License upgrading and annual service for the 6 editions of NMEA 2000 PowerTrain Simulator are summarized in Figure 1-5.

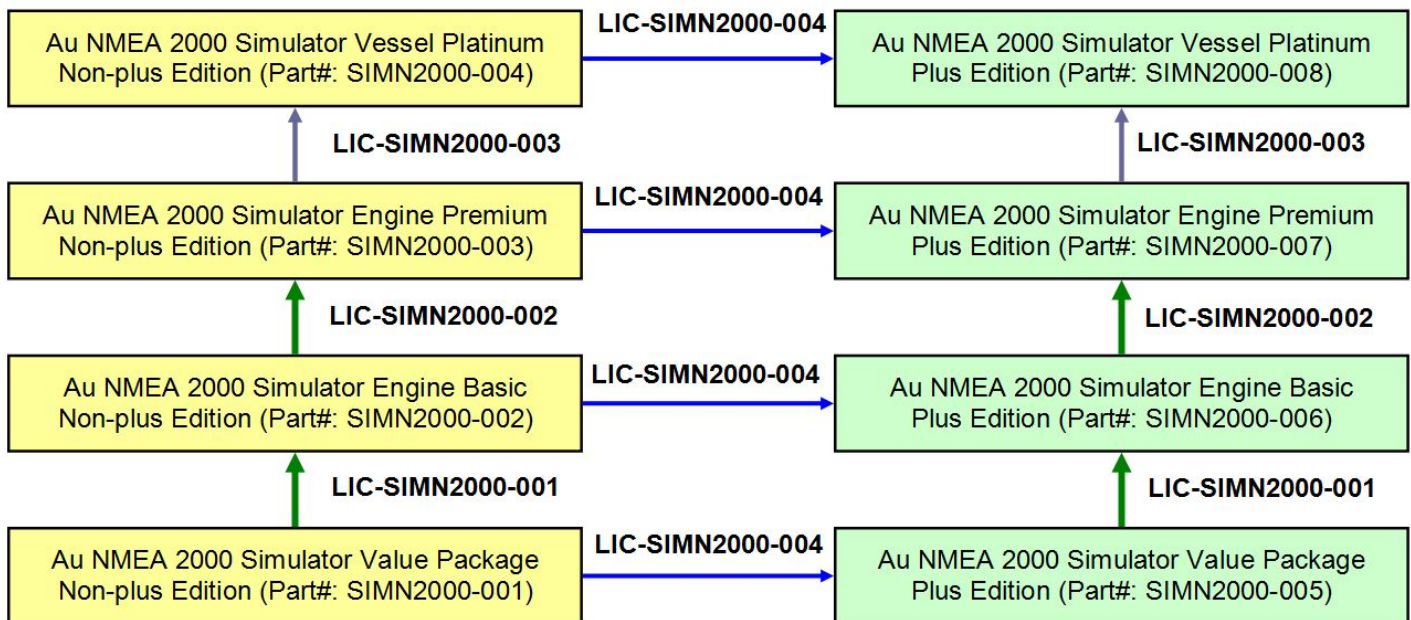

Figure 1-5 License upgrade and service for Au NMEA 2000 PowerTrain Simulators

- Simulator license can be in-field upgraded to higher editions with a license management toolset: e.g. upgrade an Au NMEA 2000 PowerTrain Simulator from Engine Basic Edition to Engine Premium Edition (LIC-SIMN2000-002) or from premium edition to platinum edition (LIC-SIMN2000-003). "Non-Plus" edition is also able to be upgraded to plus editions (LIC-SIMN2000-004).
- Software code (firmware) can be in-field updated with Au PIC Bootloader, for instance, updated firmware code or custom-made codes can be re-programmed to gain new or special features.
- One year support and minor upgrade service is available (SVS-SIMN2000).

Chapter 2 Supported NMEA 2000 Parameters

2.1. Value Package Edition(S)

Au NMEA 2000 PowerTrain Simulator Value Package Edition(s) support 6 NMEA 2000 engine parameters:

- Engine Speed (RPM)
- Engine Oil Pressure(Pa)
- Engine Temperature 1 (K)
- Engine Alternator Potential (V)
- Engine Fuel Rate (cum/hour)
- Total Engine Hour (s)

2.2. Engine Basic Edition(S)

Au NMEA 2000 PowerTrain Simulator Engine Basic Edition(s) support all 6 NMEA 2000 parameters listed with Value Package Edition(s), plus the following 20 NMEA 2000 parameters:

- | | |
|---|---|
| <ul style="list-style-type: none"> • Engine Boost Pressure (Pa) • Engine Tilt / Trim (%) • Engine Oil Temperature (K) • Engine Coolant Pressure (Pa) • Engine Fuel Pressure (Pa) • Percent Engine Load (%) • Percent Engine Torque (%) • Speed Water Referenced (m/s) • Speed Water Referenced Type • Speed Direction | <ul style="list-style-type: none"> • Exhaust gas temperature (K) • Fuel Level (%) • Fuel Tank Capacity (cum) • Battery Voltage (V) • Battery Current (A) • Battery Case Temperature (K) • Measurement Date (days) • Measurement Time (s) • Total Cumulative Distance (m) • Distance Since Last Reset(m) |
|---|---|

2.3. Engine Premium Edition(S)

Au NMEA 2000 PowerTrain Simulator Engine Premium Edition(s) support all 26 NMEA 2000 parameters listed with Engine Basic Edition(s), plus the following 2 NMEA 2000 parameters:

- Engine Discrete Status 1
- Engine Discrete Status 2

2.4. Vessel Platinum Edition(S)

Au NMEA 2000 PowerTrain Simulator Vessel Platinum Edition(s) support all 28 NMEA 2000 parameters listed with Engine Premium Edition(s), and the following 21 NMEA 2000 parameters:

- | | |
|---|--|
| <ul style="list-style-type: none"> • Waste Water Level (%) • Waste Water Tank Capacity (cum) • Black Water Level (%) • Black Water Tank Capacity (cum) • Latitude (deg) • Longitude (deg) • Port trim tab (%) • Starboard trim tab (%) • Rudder Direction Order • Rudder Angle Order (rad) • Rudder Position (rad) | <ul style="list-style-type: none"> • Water Depth (m) • Water Depth Offset (m) • Maximum Depth Range (m) • Transmission Discrete warning status • Transmission Gear • Transmission Oil Pressure (Pa) • Transmission Oil Temperature (K) • Course Over Ground Reference • Course Over Ground (rad) • Speed Over Ground (m/s) |
|---|--|

Chapter 3 Operating Instructions

All editions of Au NMEA 2000 PowerTrain Simulator can be operated by just controlling 3 push buttons. It generates NMEA 2000 signals for product developers, testers, operators and manufacturers.

3.1. Power On

Plug in a 4-wire cable (e.g. Au Part#: CBL-CAN-01) to the Au NMEA 2000 Simulator DB9 male connector (on **BUS** side). When the CBL-CAN-01 cable is used, connect the **Red** wire to +12 ~ +28V DC power supply, **Black** wire to ground, **White** wire to CAN-H, **Green** wire to CAN-L. The **Power** LED on simulator will light up, and simulator will resume the last saved operating mode (static mode or dynamic mode).

Note: the 4-wire cable (CBL-CAN-01) is color coded as shown in Table 1-2 (Chapter 1) and can be ordered separately.

3.2. Operating Modes (Static/Dynamic)

After power on, Au NMEA 2000 PowerTrain Simulator will work in either **static** mode or **dynamic** mode.

- **Static mode:** Au NMEA 2000 PowerTrain Simulator generates steady NMEA 2000 signals. In this mode, two push buttons (**Up** and **Down**) can be used to change the data outputs. When no button is pushed, all data will stay at the last value.
- **Dynamic mode:** The value of all data will change automatically in NMEA 2000 defined range.
- Switch between dynamic mode and static mode: press and hold both **Menu** and **Up** buttons until a long beep is heard if buzzer is enabled; or both the "▼0% LED" and the "▲100% LED" flip their status (from on to off or vice versa)

There are 3 push buttons (**Menu, Down, Up**) and 9 LEDs (Figure 3-1). Each LED is named after its function.

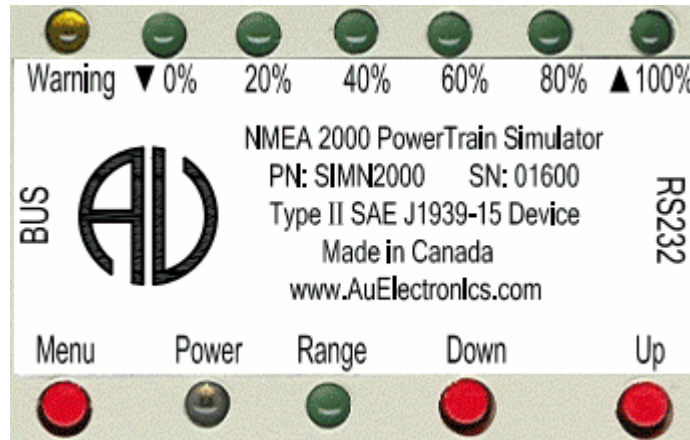

Figure 3-1 Position of push buttons and LEDs

3.3. Push Button Functions

The push button functions are summarized in Table 3-1.

Table 3-1 Summary of push button functions

Push Button Operation	Function
Press Down button	Decrease all simulated data until they reach the lowest value
Press Up button	Increase all simulated data until they reach the highest value
Press Menu button	Warning On/Off control (N.A. for Value Package and Engine Basic Edition(s))
Press & hold both Down + Up button	Buzzer ON/OFF control
Press & hold both Menu + Up button	Switch between Static/Dynamic mode

- Press **Menu** button:
 - Menu button is used to control Warning LED on/off. A single press on Menu button will turn on the Warning LED if the Warning LED was off, and vice versa.
 - The Menu button function is available only on Engine Premium Edition(s) and Vessel Platinum Edition(s). In Value Package Edition(s) and Engine Basic Edition(s), Menu button is not used, Warning LED is off.

- If buzzer is enabled, a short beep will be heard upon a press on the Menu button.

In dynamic mode, the simulator automatically adjusts the control step value by itself. This will generate dynamic NMEA 2000 signals. In static mode, all simulated NMEA 2000 signal will be controlled by the control step value, which is still able to be manually controlled by the **Up** and **Down** buttons.

- Press **Down** button:
 - **Down** button is used to decrease the values of all NMEA 2000 signals. A single press will decrease all data one step from previous values until they reach the minimum values. ▼0% LED will be triggered on or off.
 - If ▼0% LED is on, press **Down** button one time, ▼0% LED will be off.
 - If ▼0% LED is off, press **Down** button one time, ▼0% LED will be on.
 - 80% LED blinks when control step value equals to 80%,
 - 60% LED blinks when control step value equals to 60%,
 - 40% LED blinks when control step value equals to 40%,
 - 20% LED blinks when control step value equals to 20%,
 - ▼0% LED blinks when control step equals to 0%,
 - If buzzer is enabled, a short beep will be heard upon a press on Down button.
- Press **Up** button:
 - **Up** button is used to increase the values of all NMEA 2000 signals. A single press will increase all simulated data one step to next data level until they reach the maximum values, ▲100% LED will be triggered on or off.
 - If ▲100% LED is on, press **Up** button one time, ▲100% LED will be off.
 - If ▲100% LED is off, press **Up** button one time, ▲100% LED will be on.
 - 20% LED blinks when control step value equals to 20%,
 - 40% LED blinks when control step value equals to 40%,
 - 60% LED blinks when control step value equals to 60%,
 - 80% LED blinks when control step value equals to 80%,
 - ▲100% LED blinks when control step value equals to the highest value, 100%.
 - If buzzer is enabled, a short beep will be heard upon a press on **Up** button.
- Press and hold both **Down + Up** button for more than 1 second:
 - Down + Up buttons are used to turn buzzer on/off.
 - If buzzer is on, press and hold **Down + Up** for more than 1 second will silent buzzer thereafter.
 - If buzzer is mute, press and hold **Down + Up** for more than 1 second will enable the buzzer thereafter.
 - Both ▲100% and ▼0% LED will flip their on/off status as a visual indication of this dual-button input.
 - If buzzer is enabled, a long beep will be heard to reflect the input of **Down + Up** button.
- Press and hold both **Menu + Up** button for more than 1 second:
 - **Menu + Up** buttons are used to switch between static and dynamic mode.
 - Both ▲100% LED and ▼0% LED will flip their status as a visual indication of this dual-button input.
 - If buzzer is enabled, a long beep will be heard to reflect the input of **Menu + Up** button.

3.4. LED Indicator Status

Note: Red LEDs and Green LEDs are used in this document for illustration purpose; actual product might have different LED colors. Same applies to the push buttons. Au Group Electronics reserve the right of changing the color on each LEDs and push buttons without further notification.

- When power on, both **Power** LED and **Range** LED lit, as shown in Figure 3-2.

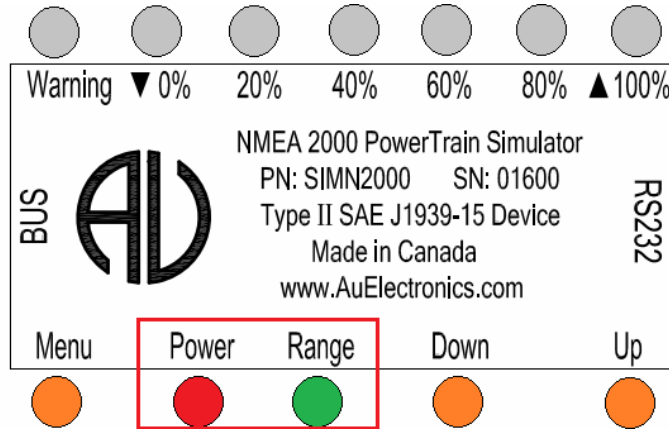

Figure 3-2 Power on, both Power and Range LED lit

All NMEA 2000 data can be changed within the NMEA 2000 defined range from 0 to 100 control steps (named 0% to 100% control step value from now on), 6 LEDs are used to identify the control step value in the range of 0%, 20%, 40%, 60%, 80%, and 100%.

- ▲100% LED will be triggered on or off with a press on the **Up** button, accompany with the increasing brightness of **Range** LED. A press on the **Up** button will also increase the control step value and all simulated data.
 - When control step value equals to 0%, the ▼0% LED blinks.
 - When control step value equals to 20%, 20% LED blinks.
 - If keep pressing **Up** button, the control step value will keep increasing. The 20% LED will then be always on, as shown in Figure 3-3. This indicates a data range from 21- 39%.

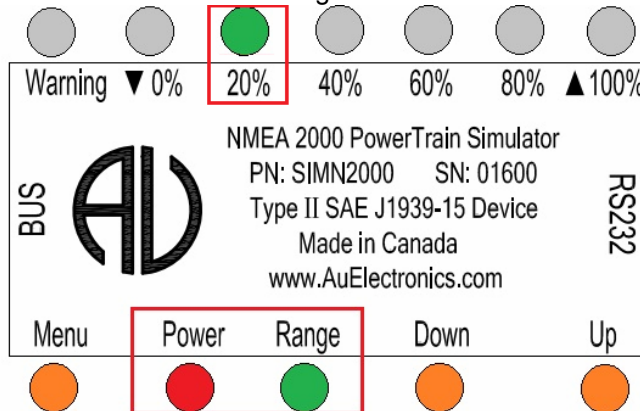

Figure 3-3 Power, Range, 20% LED on, indicating data range is from 21% to 39%

- When control step value equals to 40%, 40% LED blinks.
- If keep pressing **Up** button, the control step value will keep increasing. The 20% and 40% LED will be always on, as shown in Figure 3-4. It indicates the data range from 41% to 59%.

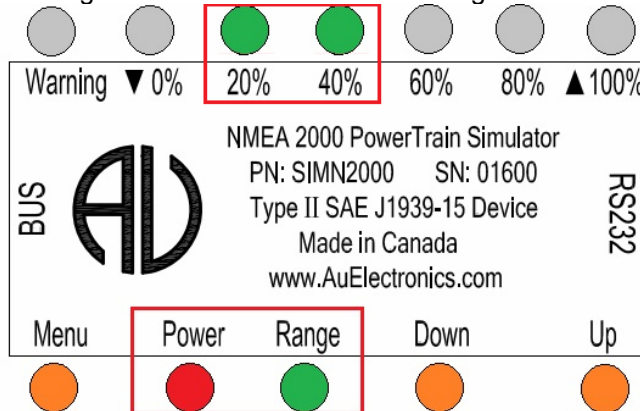

Figure 3-4 Power, Range, 20%, 40% LED on, indicating data range is from 41% to 59%

- When control step value equals to 60%, 60% LED blinks
- If keep pressing **Up** button, the control step value will keep increasing. The 20%, 40%, and 60% LED will be on, as shown in Figure 3-5. It indicates the data range from 61% to 79%.

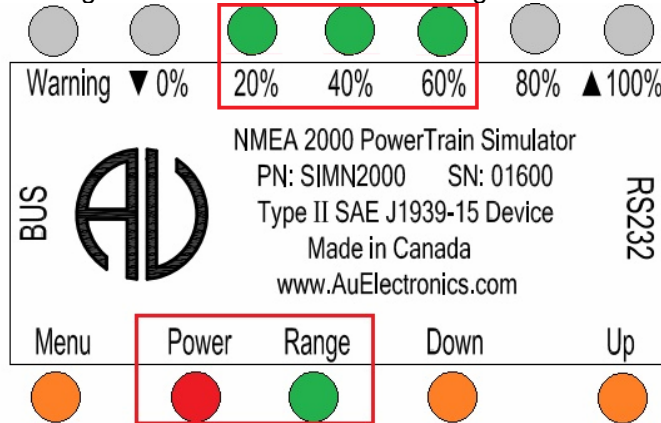

Figure 3-5 Power, Range, 20%, 40%, 60% LED on, indicating data range is from 61% to 79%

- When control step value equals to 80%, 80% LED blinks.
- If keep pressing **Up** button, the control step value will keep increasing. The 20%, 40%, 60%, and 80% LED will be on, as shown in Figure 3-6. It indicates the data range from 81% to 99%.

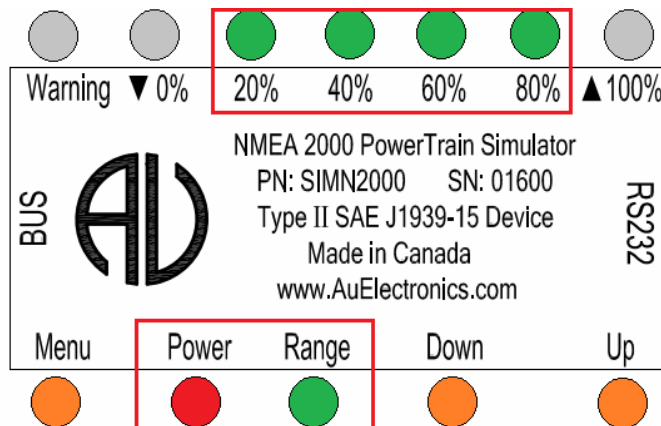

Figure 3-6 Power, Range, 20%, 40%, 60%, 80% LED on, indicating data range is from 81% to 99%

- When control step value equals to 100%, the 20%, 40%, 60%, and 80% LED will be constant on. ▲100% LED blinks, as shown in Figure 3-7.

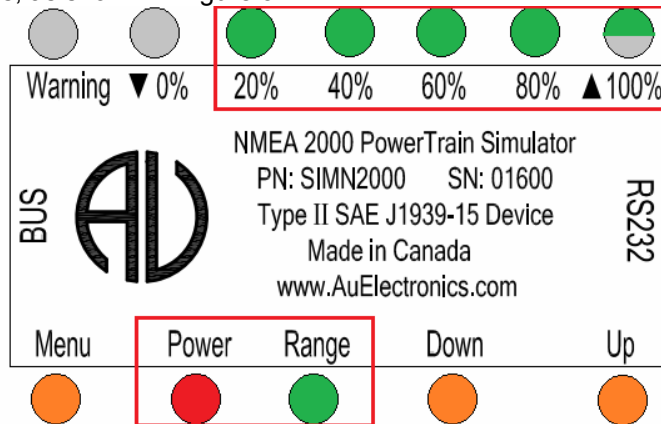

Figure 3-7 Power, Range, 20%, 40%, 60%, 80% are constant on, “▲100%” LED blinks, indicating data reaches 100%

- ▼0% LED will be triggered on or off when pressing **Down** button, accompany with the decreasing brightness of Range LED. A press on the **Down** button will also decrease the control step value and all simulated data. When the control step value equals to 0%, ▼0% LED blinks.



The control step value vs. LED indicator status is summarized in Table 3-2.

Table 3-2 Control step value vs. LED indicator status (in Static Mode)

Step	Operation	LED Status
1	Connect +12~+28 V DC power supply	Power, Range LED on, the rest LED will recall the last saved status at Static mode
2	Press Down button	▼ 0% LED on/off
3	Continue press Down button until control step value = 0%	▼ 0% LED blink
4	Press Up button	▲ 100% LED on/off
5	Continue press Up button for control step value 1 to 19%	Power, Range LED constant on
6	Continue press Up button for control step value 20%	Power, Range LED on, 20% LED Blink
7	Continue press Up button for control step value 21 to 39%	Power, Range LED on, 20% LED on
8	Continue press Up button for control step value 40%	Power, Range, 20% LED ON, 40% LED Blink
9	Continue press Up button for control step value 41 to 59%	Power, Range, 20%, 40% LED on
10	Continue press Up button for control step value 60%	Power, Range, 20%, 40% LED on, 60% LED blink
11	Continue press Up button for control step value 61 to 79%	Power, Range, 20%, 40%, 60% LED on
12	Continue press Up button for control step value 80%	Power, Range, 20%,40%, 60% LED on, 80% LED blink
13	Continue press Up button for control step value 81 to 99%	Power, Range, 20%, 40%, 60%, 80% LED on
14	Continue press Up button for control step value 100%	Power, Range, 20%, 40%, 60%, 80% LED on, ▲ 100% blink

Chapter 4 Au NMEA 2000 PowerTrain Simulator Remote Terminal

For all Au NMEA 2000 Simulator "Plus" editions, the "Au NMEA 2000 PowerTrain Simulator Remote Terminal" software can be used to control and display simulated NMEA 2000 signals from a personal computer.

The Remote Terminal GUI (Graphic User Interface) includes a control panel, Source Address, Device Instance, Sequence ID, and display Panel, as shown in Figure 4 - 1.

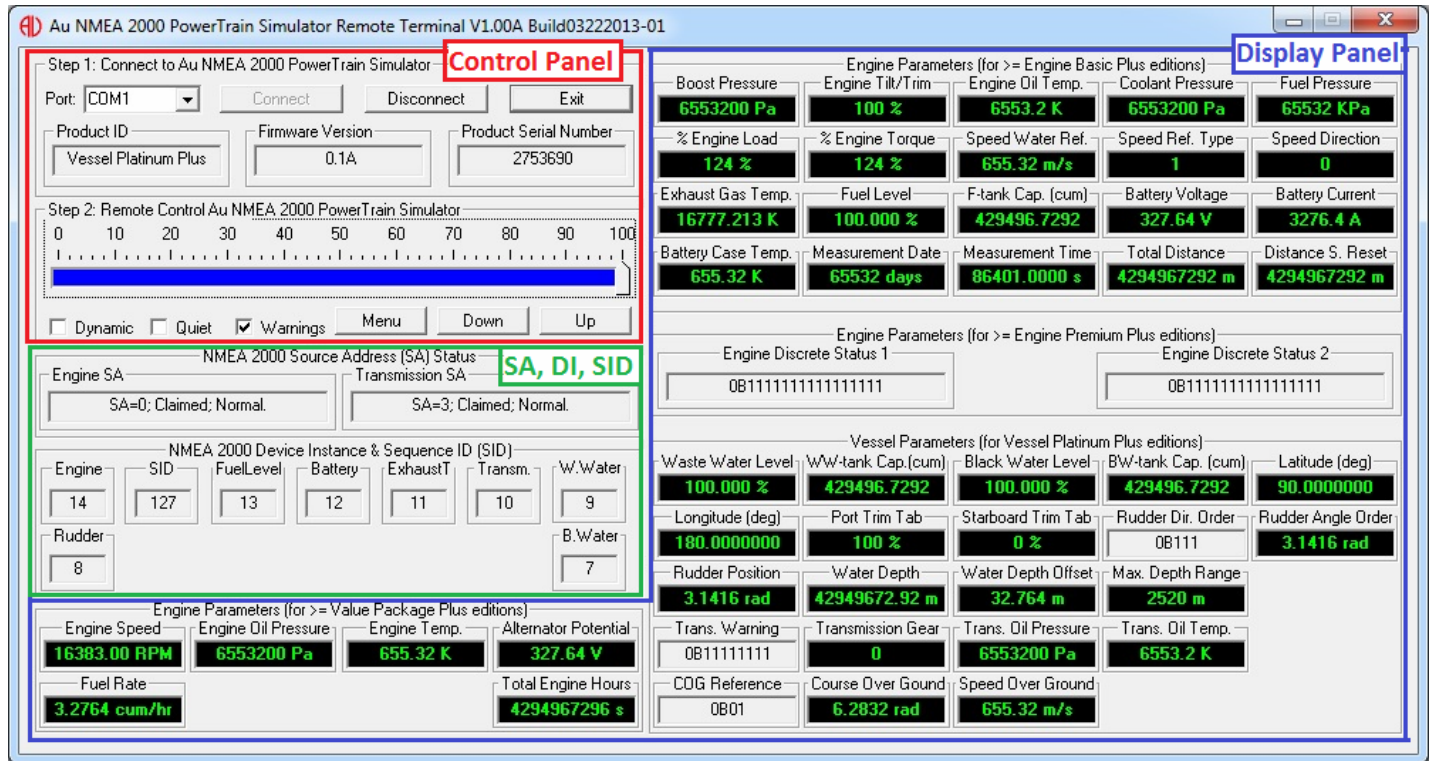

Figure 4 - 1 PC Remote Terminal GUI for Vessel Platinum Plus Edition

Following paragraphs will explain how to use the GUI remote-control of AU NMEA 2000 PowerTrain Simulator.

4.1. Connect To AU NMEA 2000 PowerTrain Simulator

Connect Au NMEA 2000 PowerTrain simulator to power supply and a NMEA 2000 network, and then connect it to a PC serial port.

Select serial port from the "Port" drop down list → click "Connect" button → Product information of the connected AU NMEA 2000 PowerTrain simulator will display (Product ID, Firmware Version, and Product Serial number), as shown in Figure 4-2.

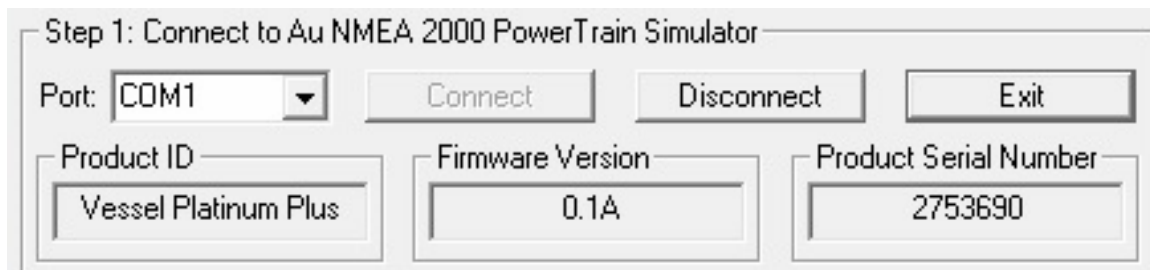

Figure 4-2 Au NMEA 2000 PowerTrain simulator remote terminal control panel step

Note: The control panel step 1 can always be used to display Product ID, Firmware Version, and Product Serial Number for all Au NMEA 2000 PowerTrain simulator Editions (both plus edition and non-plus edition).

The function of step 1 control items is summarized in Table 4-1.

Table 4-1 Function summary of step 1 control items

Items	Function
Port	Serial port can be selected from drop down list (COM1 to COM30)
Connect	Click “Connect” button to connect NMEA 2000 PowerTrain simulator with selected PC serial port.
Disconnect	Click “Disconnect” button to release the selected PC serial port.
Exit	Click “Exit” button to close Au NMEA 2000 PowerTrain simulator remote terminal program
Product ID	Display the current edition of Au NMEA 2000 PowerTrain simulator that’s hooked up with the serial port. (e.g. The demonstration in Figure 4-2 is a Vessel Platinum Plus Edition)
Simulator Version	Display the current firmware version of Au NMEA 2000 PowerTrain simulator that’s hooked up with the serial port. (The demonstrated version of the connected simulator in Figure 4-2 is 0.1A)
Product Serial Number	Display the serial number of Au NMEA 2000 PowerTrain simulator that’s connected to the serial port. (The demonstrated serial number for the connected simulator in Figure 4-2 is 2753690)

4.2. Remote Control Au NMEA 2000 PowerTrain Simulator

Remote control includes a scale bar, 3 push buttons (**Menu, Down, Up**), and 3 check boxes (Dynamic, Quiet, Warnings) as shown in Figure 4-3. These tools are able to remote control the output/simulated signal of the Au NMEA 2000 PowerTrain Simulator **PLUS** editions.

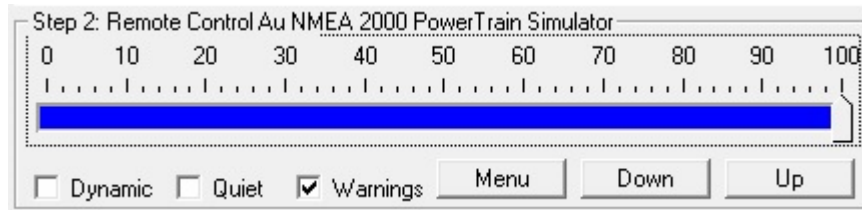

Figure 4-3 PC remote terminal control panel step 2

The scale bar represents the control step values from 0% to 100%. The sliding action can be made by 3 methods: keyboard, mouse or Down/Up buttons from remote terminal. They are summarized in Table 4-2

Table 4-2 Control methods for scale bar

	Action	Function
Mouse	Left click	Left click bring the slide to the desire location.
	Drag	Click and hold left button drag the slide to desire location
Keyboard	▲ or ►	Increase the scale range in 1 interval
	▼ or ◀	Decrease the scale range in 1 interval
	Pg Up	Increase the scale range in 10 interval
	Pg Dn	Decrease the scale range in 10 interval
Remote terminal	“Down” button	Decrease the scale range in 1 interval
	“Up” button	Increase the scale range in 1 interval

The functions for the 3 push buttons and 4 check boxes are listed in Table 4-3.

Table 4-3 Functions for push button and check boxes in step 2

Tool	Function	
Button	Menu*	Turn on/off warning (see note below)
	Down	Decrease the control step value in 1
	Up	Increase the control step value in 1
Check box	Dynamic	Switch between dynamic mode / static mode
	Quiet	Turn on/off buzzer
	Warning	Turn on/off Warning

***Note:** Menu button is active only in the **Engine Premium Plus** edition and **Vessel Platinum Plus** edition.

4.3. NMEA 2000 Source Address Status

For Au NMEA 2000 Simulator Value Package Plus edition, Engine Basic Plus edition, and Engine Premium Plus edition, only **Engine Source Address** are available to be displayed in the NMEA 2000 SA Status area, as shown in Figure 4 - 4.

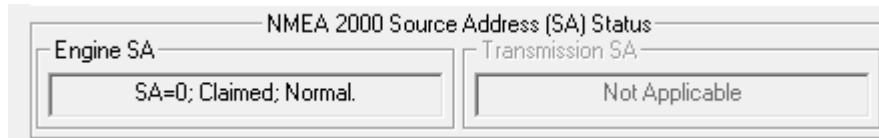

Figure 4 - 4 Engine SA Status

For Au NMEA 2000 Simulator Vessel Platinum Plus Edition, both Engine Source Address and Transmission Source Address are available to be displayed in the NMEA 2000 SA Status area, as shown in Figure 4 - 5.

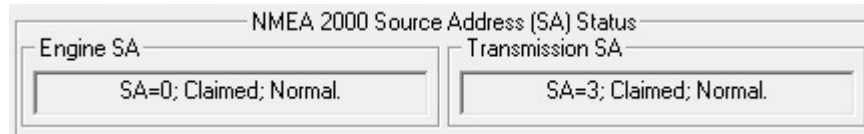

Figure 4-5 Engine SA and Transmission SA Status

4.4. NMEA 2000 Device Instance & Sequence ID (SID)

For Value Package Plus edition, only Engine Instance are available to be display, as shown in Figure 4 - 6.



Figure 4 - 6 Engine Instance ID is available for Value Package Plus Edition

Engine Instance , Sequence ID, Fuel Level Instance, Battery Instance, and Exhaust Temperature Instance are available to be displayed for Engine Basic and Engine Premium Plus Edition, as shown in Figure 4 - 7.

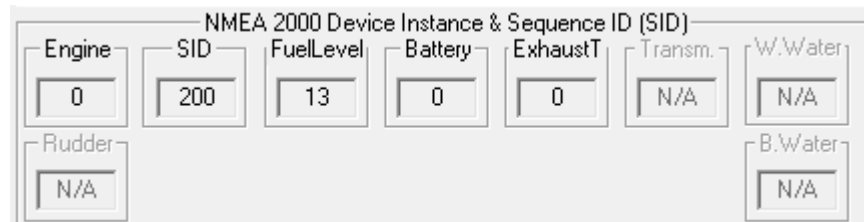

Figure 4 - 7 Available NMEA 2000 Device ID & SID for Engine Basic and Engine Premium Plus Edition

Engine Instance, Sequence ID, Fuel Level Instance, Battery Instance, Exhaust Temperature Instance, Transmission Instance, Waste Water Instance, Rudder Instance, Black Water Instance are available to be displayed for Vessel Platinum Plus Edition, as shown in Figure 4 - 8

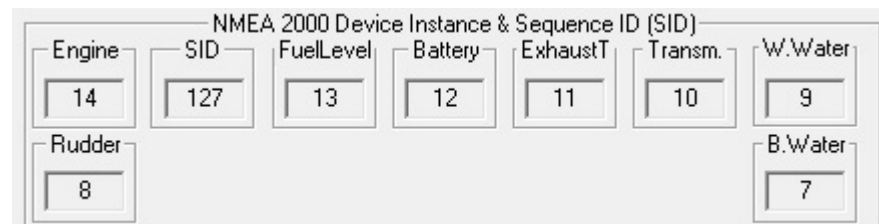

Figure 4 - 8 NMEA 2000 Device Instance & SID for Vessel Premium Plus Edition

NMEA 2000 Device Instance can be set in the remote terminal GUI by following the instruction below:

- 1, Click the Au Icon at the upper left corner of the Remote terminal GUI (Figure 4 - 9)

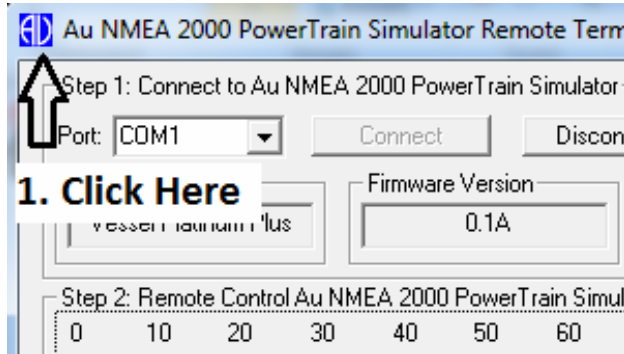

Figure 4 - 9

2. Click "About SIMN2000..." (Figure 4 - 10)

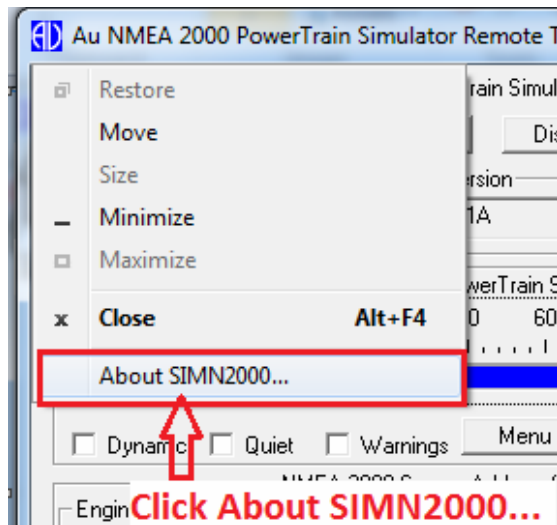

Figure 4 - 10

3. Under NMEA 2000 Device Instance Management area, click "Proceed to Change Device Instance" button, as shown in Figure 4 - 11.

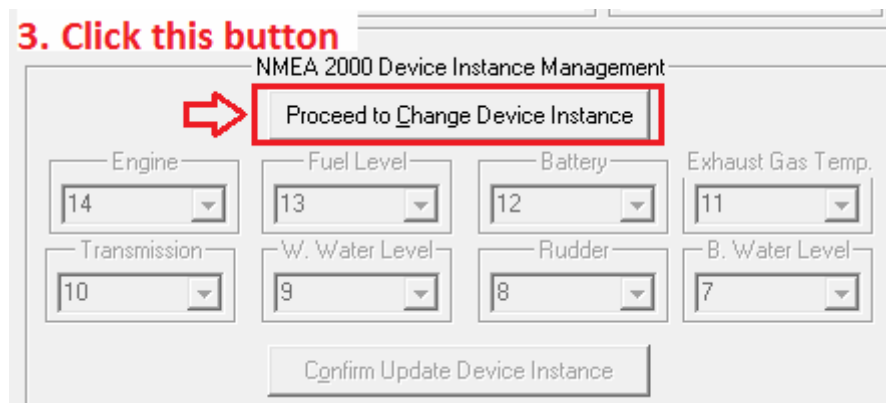

Figure 4 - 11

4. Change device instance to desire value from 1 to 15, then press "Confirm Update Device Instance" button, as shown in Figure 4 - 12.

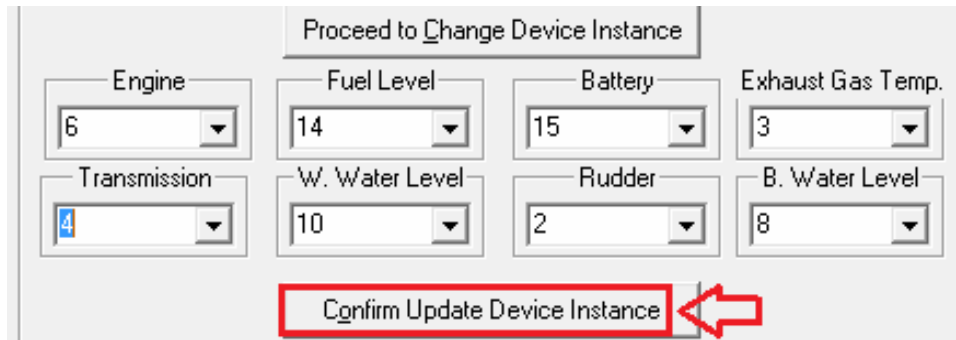

Figure 4 - 12

4.5. 6 Engine Parameters for Value Package Edition

There are 6 parameters simulated in Value Package Edition: Engine Speed, Engine Oil Pressure, Engine Temperature, Alternator Potential, Fuel Rate, Total Engine Hours, as shown in Figure 4 - 13.

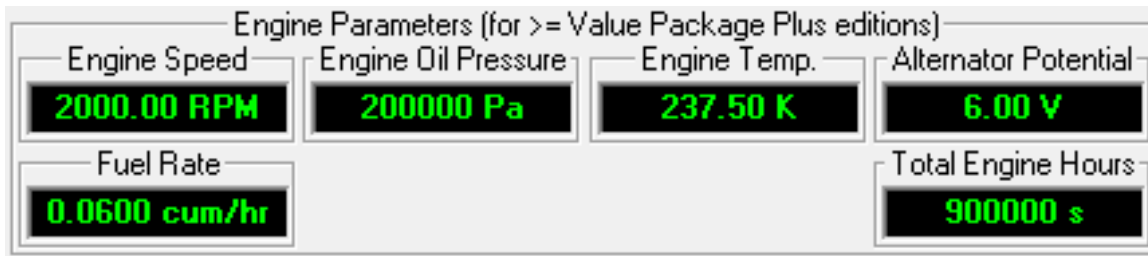

Figure 4 - 13 6 Engine Parameters for Value Package Edition

4.6. 20 Engine Basic Parameters

Engine Basic Editions simulated 26 parameters, including the 6 parameters simulated in Value Package Edition, plus 20 Engine Basic parameters: Engine Boost Pressure, Engine Tilt / Trim, Engine Oil Temperature (K), Engine Coolant Pressure, Engine Fuel Pressure (Pa), Percent Engine Load, Percent Engine Torque, Speed Water Referenced Speed Water Referenced Type, Speed Direction, Exhaust gas temperature, Fuel Level, Fuel Tank Capacity, Battery Voltage, Battery Current, Battery Case Temperature, Measurement Date, Measurement Time, Total Cumulative Distance, Distance Since Last Reset, as shown in Figure 4 - 14.

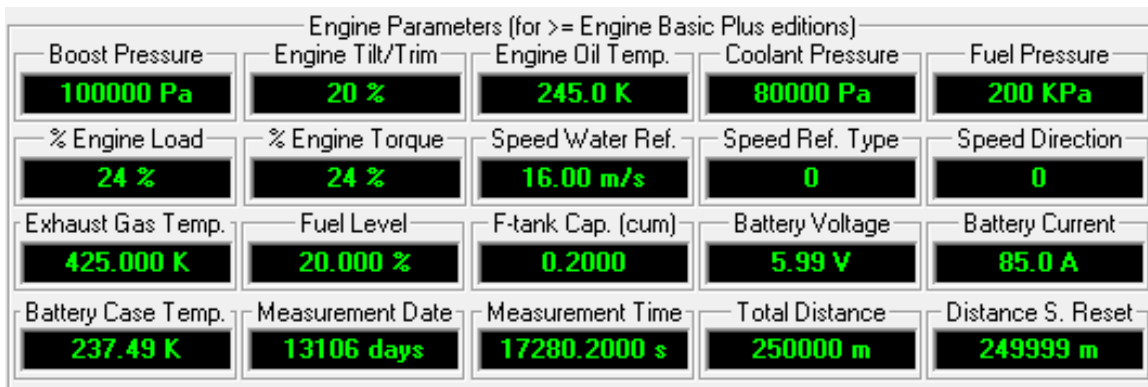

Figure 4 - 14 20 Engine Basic Parameters for Engine Basic Edition

4.7. Engine Discrete Statuses for Engine Premium Edition

Engine Premium Edition simulates 28 parameters, including 26 parameters supported by Engine Basic edition, plus 2 Engine Parameters: Engine Discrete Status 1 and Engine Discrete Status 2, as shown in Figure 4 - 15.

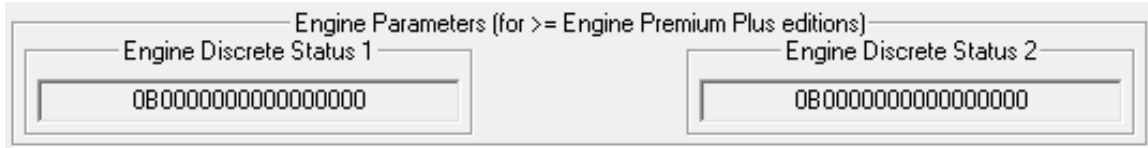

Figure 4-15 Display ABS info and warning lamps

4.8. 21 Vessel Parameters for Vessel Platinum Edition

Vessel Platinum edition of Au NMEA 2000 PowerTrain Simulator support all 28 parameters supported by Engine Premium edition, plus the following 21 Vessel Parameters:

Waste Water Level, Waste Water Tank Capacity, Black Water Level, Black Water Tank Capacity, Latitude, Longitude, Port trim tab, Starboard trim tab, Rudder Direction Order, Rudder Angle Order, Rudder Position, Water Depth, Water Depth Offset, Maximum Depth Range, Transmission Discrete warning status, Transmission Gear, Transmission Oil Pressure, Transmission Oil Temperature, Course Over Ground Reference, Course Over Ground, Speed Over Ground, as shown in Figure 4-16.

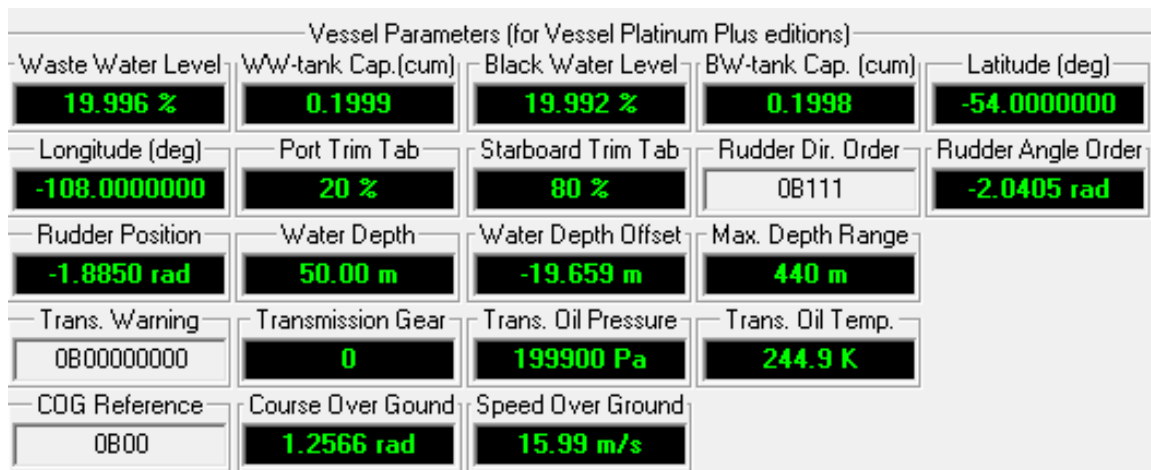

Figure 4 - 16



Chapter 5 Data Configuration

The PGNs simulated in Au NMEA 2000 Simulators are summarized in Table 5 - 1.

Table 5 - 1 PGN list for Au NMEA 2000 Simulator

PGN: 127488	Engine Parameters, Rapid Update	Supported Parameters	
Hex	1F200	• Engine Instance	DD128
Priority	2	• Engine Speed	DD129
Single Frame	Yes	• Engine Boost Pressure	DD049
Update Rate (ms)	100	• Engine tilt/trim	DD138
PGN: 127489	Engine Parameters, Dynamic	Supported Parameters	
Hex	1F201	• Engine Instance	DD128
Priority	2	• Engine Oil Pressure	DD049
Single Frame	No	• Engine oil temp.	DD130
Update Rate (ms)	500	• Engine temp	DD043
		• Alternator potential	DD136
		• Fuel Rate	DD131
		• Total engine hours	DD132
		• Engine coolant Pressure	DD049
		• Fuel Pressure	DD225
		• Engine Discrete Status 1	DD206
		• Engine Discrete Status 2	DD223
		• Percent Engine Load	DD138
		• Percent Engine Torque	DD138
PGN: 128259	Speed, Water Referenced	Supported Parameters	
Hex	1F503	• Sequence ID	DD056
Priority	2	• Speed Water Referenced	DD044
Single Frame	Yes	• Speed Water Referenced Type	DD293
Update Rate (ms)	1000	• Speed Direction	DD356
PGN: 130316	Temperature, Extended Range	Supported Parameters	
Hex	1FD0C	• Exhaust Gas Temperature SID	DD056
Priority	5	• Temperature Source	DD291
Single Frame	Yes	• Exhaust Gas Temperature	DD314
Update Rate (ms)	2s		
PGN: 127505	Fluid Level	Supported Parameters	
Hex	1F211	• Fluid Instance	DD169
Priority	6	• Fluid Type	DD208
Single Frame	Yes	• Fuel Level	DD215
Update Rate (ms)	2500	• Tank Capacity (cu-m)	DD227
		• Waste Water Level	DD215
		• Waste Water Tank Capacity	DD227
		• Black Water Level	DD215
		• Black Water Tank Capacity	DD227
PGN: 127508	Battery Status	Supported Parameters	
Hex	1F214	• Battery Instance	DD005
Priority	6	• Battery Voltage	DD136
Single Frame	Yes	• Battery Current	DD140
Update Rate (ms)	1500	• Battery Case Temperature	DD043
PGN: 128275	Distance Log	Supported Parameters	
Hex	1F513	• Measurement Date	DD039
Priority	6	• Measurement Time	DD158
Single Frame	No	• Total Cumulative Distance	DD120
Update Rate (ms)	1000	• Distance Since Last Reset	DD120



PGN: 127493	Transmission Parameters, Dynamic	Supported Parameters
Hex	1F205	• Transmission Instance DD128
Priority	2	• Transmission Gear DD222
Single Frame	Yes	• Transmission Oil Pressure DD049
Update Rate (ms)	100	• Transmission Oil temperature DD130
		• Transmission Discrete Status DD221
PGN: 130576	Trim Tab Status	Supported Parameters
Hex	1FE10	• Port Trim tab DD138
Priority	2	• Starboard Trim Tab DD138
Single Frame	Yes	
Update Rate (ms)	200	
PGN: 127245	Rudder	Supported Parameters
Hex	1F10D	• Rudder Instance DD128
Priority	2	• Direction Order DD147
Single Frame	Yes	• Angle Order DD146
Update Rate (ms)	200	• Rudder Position DD146
PGN: 128267	Water Depth	Supported Parameters
Hex	1F50B	• Water Depth SID DD056
Priority	3	• Water Depth Transducer DD162
Single Frame	Yes	• Offset DD161
Update Rate (ms)	1000	• Max. depth Range DD350
PGN: 129026	COG & SOG, Rapid Update	Supported Parameters
Hex	1F802	• SID DD056
Priority	2	• COG Reference DD117
Single Frame	Yes	• Course Over Ground DD165
Update Rate (ms)	250	• Speed Over Ground DD044
PGN: 129025	Position, Rapid Update	Supported Parameters
Hex	1F801	• Latitude DD022
Priority	2	• Longitude DD023
Single Frame	Yes	
Update Rate (ms)	100	

5.1. Simulation Data for SIMN2000 Value Package Edition

The simulation results of the 6 Engine parameters supported by AU NMEA 2000 Simulator Value package edition are listed in Table 5-2, 5-3, 5-4.

Table 5 - 2 Engine Parameters for Value Package Edition (from Step 0 - 20%)

Step	Engine Speed (RPM)	Engine Oil Pressure	Engine Temp (k)	Alternator potential (V)	Fuel Rate (cu-m/hr)	Engine Hour (s)
0	0	0	0	-327.64	-3.2764	0
1	100	10000	40	-262.12	-2.6212	45000
2	200	20000	80	-196.59	-1.9659	90000
3	300	30000	120	-131.06	-1.3106	135000
4	400	40000	160	-65.53	-0.6553	180000
5	500	50000	200	0.00	0.0000	225000
6	600	60000	203	0.40	0.0040	270000
7	700	70000	206	0.80	0.0080	315000
8	800	80000	209	1.20	0.0120	360000
9	900	90000	212	1.60	0.0160	405000
10	1000	100000	215	2.00	0.0200	450000
11	1100	110000	218	2.40	0.0240	495000



Table 5 - 3 Engine Parameters for Value Package Edition (from Step 12 - 55%)

Step	Engine Speed (RPM)	Engine Oil Pressure (Pa)	Engine Temp (k)	Alternator potential (V)	Fuel Rate (cu-m/hr)	Engine Hour (s)
12	1200	120000	221	2.80	0.0280	540000
13	1300	130000	224	3.20	0.0320	585000
14	1400	140000	227	3.60	0.0360	630000
15	1500	150000	230	4.00	0.0400	675000
16	1600	160000	233	4.40	0.0440	720000
17	1700	170000	236	4.80	0.0480	765000
18	1800	180000	239	5.20	0.0520	810000
19	1900	190000	242	5.60	0.0560	855000
20	2000	200000	245	6.00	0.0600	900000
21	2100	210000	248	6.40	0.0640	945000
22	2200	220000	251	6.80	0.0680	990000
23	2300	230000	254	7.20	0.0720	1035000
24	2400	240000	257	7.60	0.0760	1080000
25	2500	250000	260	8.00	0.0800	1125000
26	2600	260000	263	8.40	0.0840	1170000
27	2700	270000	266	8.80	0.0880	1215000
28	2800	280000	269	9.20	0.0920	1260000
29	2900	290000	272	9.60	0.0960	1305000
30	3000	300000	275	10.00	0.1000	1350000
31	3100	310000	278	10.40	0.1040	1395000
32	3200	320000	281	10.80	0.1080	1440000
33	3300	330000	284	11.20	0.1120	1485000
34	3400	340000	287	11.60	0.1160	1530000
35	3500	350000	290	12.00	0.1200	1575000
36	3600	360000	293	12.40	0.1240	1620000
37	3700	370000	296	12.80	0.1280	1665000
38	3800	380000	299	13.20	0.1320	1710000
39	3900	390000	302	13.60	0.1360	1755000
40	4000	400000	305	14.00	0.1400	1800000
41	4100	410000	308	14.40	0.1440	1845000
42	4200	420000	311	14.80	0.1480	1890000
43	4300	430000	314	15.20	0.1520	1935000
44	4400	440000	317	15.60	0.1560	1980000
45	4500	450000	320	16.00	0.1600	2025000
46	4600	460000	323	16.40	0.1640	2070000
47	4700	470000	326	16.80	0.1680	2115000
48	4800	480000	329	17.20	0.1720	2160000
49	4900	490000	332	17.60	0.1760	2205000
50	5000	500000	335	18.00	0.1800	2250000
51	5100	510000	338	18.40	0.1840	2295000
52	5200	520000	341	18.80	0.1880	2340000
53	5300	530000	344	19.20	0.1920	2385000
54	5400	540000	347	19.60	0.1960	2430000
55	5500	550000	350	20.00	0.2000	2475000



Table 5 - 4 Engine Parameters for Value Package Edition (from Step 56 - 100)

Step	Engine Speed (RPM)	Engine Oil Pressure (Pa)	Engine Temp (k)	Alternator potential (V)	Fuel Rate (cu-m/hr)	Engine Hour (s)
56	5600	560000	353	20.40	0.2040	2520000
57	5700	570000	356	20.80	0.2080	2565000
58	5800	580000	359	21.20	0.2120	2610000
59	5900	590000	362	21.60	0.2160	2655000
60	6000	600000	365	22.00	0.2200	2700000
61	6100	610000	368	22.40	0.2240	2745000
62	6200	620000	371	22.80	0.2280	2790000
63	6300	630000	374	23.20	0.2320	2835000
64	6400	640000	377	23.60	0.2360	2880000
65	6500	650000	380	24.00	0.2400	2925000
66	6600	660000	383	24.40	0.2440	2970000
67	6700	670000	386	24.80	0.2480	3015000
68	6800	680000	389	25.20	0.2520	3060000
69	6900	690000	392	25.60	0.2560	3105000
70	7000	700000	395	26.00	0.2600	3150000
71	7100	710000	398	26.40	0.2640	3195000
72	7200	720000	401	26.80	0.2680	3240000
73	7300	730000	404	27.20	0.2720	3285000
74	7400	740000	407	27.60	0.2760	3330000
75	7500	750000	410	28.00	0.2800	3375000
76	7600	760000	413	28.40	0.2840	3420000
77	7700	770000	416	28.80	0.2880	3465000
78	7800	780000	419	29.20	0.2920	3510000
79	7900	790000	422	29.60	0.2960	3555000
80	8000	800000	425	30.00	0.3000	3600000
81	8419	1087600	428	30.40	0.3040	218168364
82	8838.25	1375300	431	30.80	0.3080	432736729
83	9257.25	1662900	434	31.20	0.3120	647305093
84	9676.5	1950600	437	31.60	0.3160	861873458
85	10095.75	2238300	440	32.00	0.3200	1076441823
86	10514.75	2525900	847.5	51.70	0.5170	1291010187
87	10934	2813600	1255	71.41	0.7141	1505578552
88	11353	3101200	1662.6	91.12	0.9112	1720146916
89	11772.25	3388900	2070.1	110.83	1.1083	1934715281
90	12191.5	3676600	2477.7	130.54	1.3054	2149283646
91	12610.5	3964200	2885.2	150.25	1.5025	2363852010
92	13029.75	4251900	3292.8	169.96	1.6996	2578420375
93	13448.75	4539500	3700.3	189.67	1.8967	2792988739
94	13868	4827200	4107.9	209.38	2.0938	3007557104
95	14287.25	5114900	4515.4	229.09	2.2909	3222125469
96	14706.25	5402500	4923	248.80	2.4880	3436693833
97	15125.5	5690200	5330.5	268.51	2.6851	3651262198
98	15544.5	5977800	5738.1	288.22	2.8822	3865830562
99	15963.75	6265500	6145.6	307.93	3.0793	4080398927
100	16383	6553200	6553.2	327.64	3.2764	4294967292

5.2. Simulation Data for SIMN2000 Engine Basic Edition

Au NMEA 2000 Simulator Engine Basic Editions simulated 26 parameters, including the 6 parameters simulated in Value Package Edition, plus 20 Engine Basic parameters, the simulation results vs. control step are summarized in the table from 5 - 5 to 5 - 15.



Table 5 - 5 Engine Parameters for Engine Basic Edition (from Step 0 - 10)

Step	0	1	2	3	4	5	6	7	8	9	10
Engine Boost Pressure (Pa)	0	5000	10000	15000	20000	25000	30000	35000	40000	45000	50000
Engine tilt/trim	0.00%	1.00%	2.00%	3.00%	4.00%	5.00%	6.00%	7.00%	8.00%	9.00%	10.00%
Engine oil temp. (k)	0	40	80	120	160	200	203	206	209	212	215
Engine coolant Pressure (Pa)	0	4000	8000	12000	16000	20000	24000	28000	32000	36000	40000
Fuel Pressure (Pa)	0	10000	20000	30000	40000	50000	60000	70000	80000	90000	100000
Engine Load %	0%	1%	2%	3%	4%	6%	7%	8%	9%	11%	12%
Engine Torque %	0%	1%	2%	3%	4%	6%	7%	8%	9%	11%	12%
Speed Water Referenced	0	0.8	1.6	2.4	3.2	4	4.8	5.6	6.4	7.2	8
Speed Water Referenced Type	0	0	0	0	0	0	0	0	0	0	0
Speed Direction	1	1	1	1	1	1	15	0	0	0	0
Exhaust Gas Temperature (K)	0	40	80	120	160	200	215	230	245	260	275
Fuel Level (type 0)	0.000%	1.000%	2.000%	3.000%	4.000%	5.000%	6.000%	7.000%	8.000%	9.000%	10.000%
Tank Capacity (cu-m)	0.0000	0.0100	0.0200	0.0300	0.0400	0.0500	0.0600	0.0700	0.0800	0.0900	0.1000
Battery Voltage	-327.64	-262.13	-196.6	-131.07	-65.54	-0.01	0.39	0.79	1.19	1.59	1.99
Battery Current	-3276.4	-2637.2	-1997.9	-1358.6	-719.3	-80	-69	-58	-47	-36	-25
Battery Case Temperature	0	39.99	79.99	119.99	159.99	199.99	202.49	204.99	207.49	209.99	212.49
Measurement Date	0	655	1310	1965	2621	3276	3931	4587	5242	5897	6553
Measurement Time	0	864.01	1728	2592	3456	4320.1	5184.1	6048.1	6912.1	7776.1	8640.1
Total Distance	0	12500	25000	37500	50000	62500	75000	87500	100000	112500	125000
Distance Since Last Reset	0	12499	24999	37499	49999	62499	74999	87499	99999	112499	124999



Table 5 - 6 Engine Parameters for Engine Basic Edition (from Step 11 - 20)

Step	11	12	13	14	15	16	17	18	19	20
Engine Boost Pressure (Pa)	55000	60000	65000	70000	75000	80000	85000	90000	95000	100000
Engine tilt/trim	11.00%	12.00%	13.00%	14.00%	15.00%	16.00%	17.00%	18.00%	19.00%	20.00%
Engine oil temp. (k)	218	221	224	227	230	233	236	239	242	245
Engine coolant Pressure (Pa)	44000	48000	52000	56000	60000	64000	68000	72000	76000	80000
Fuel Pressure (Pa)	110000	120000	130000	140000	150000	160000	170000	180000	190000	200000
Engine Load %	13%	14%	16%	17%	18%	19%	21%	22%	23%	24%
Engine Torque %	13%	14%	16%	17%	18%	19%	21%	22%	23%	24%
Speed Water Referenced	8.8	9.6	10.4	11.2	12	12.8	13.6	14.4	15.2	16
Speed Water Referenced Type	0	0	0	0	0	0	0	0	0	0
Speed Direction	0	0	0	0	0	0	0	0	0	0
Exhaust Gas Temperature (K)	290	305	320	335	350	365	380	395	410	425
Fuel Level (type 0)	11.0000%	12.0000%	13.0000%	14.0000%	15.0000%	16.0000%	17.0000%	18.0000%	19.0000%	20.0000%
Tank Capacity (cu-m)	0.1100	0.1200	0.1300	0.1400	0.1500	0.1600	0.1700	0.1800	0.1900	0.2000
Battery Voltage	2.39	2.79	3.19	3.59	3.99	4.39	4.79	5.19	5.59	5.99
Battery Current	-14	-3	8	19	30	41	52	63	74	85
Battery Case Temperature	214.99	217.49	219.99	222.49	224.99	227.49	229.99	232.49	234.99	237.49
Measurement Date	7208	7863	8519	9174	9829	10485	11140	11795	12451	13106
Measurement Time	9504.11	10368.1	11232.1	12096.1	12960.2	13824.2	14688.2	15552.2	16416.2	17280.2
Total Distance	137500	150000	162500	175000	187500	200000	212500	225000	237500	250000
Distance Since Last Reset	137499	149999	162499	174999	187499	199999	212499	224999	237499	249999



Table 5 - 7 Engine Parameters for Engine Basic Edition (from Step 21 - 30)

Step	21	22	23	24	25	26	27	28	29	30
Engine Boost Pressure (Pa)	105000	110000	115000	120000	125000	130000	135000	140000	145000	150000
Engine tilt/trim	21.00%	22.00%	23.00%	24.00%	25.00%	26.00%	27.00%	28.00%	29.00%	30.00%
Engine oil temp. (k)	248	251	254	257	260	263	266	269	272	275
Engine coolant Pressure (Pa)	84000	88000	92000	96000	100000	104000	108000	112000	116000	120000
Fuel Pressure (Pa)	210000	220000	230000	240000	250000	260000	270000	280000	290000	300000
Engine Load %	26%	27%	28%	29%	31%	32%	33%	34%	35%	37%
Engine Torque %	26%	27%	28%	29%	31%	32%	33%	34%	35%	37%
Speed Water Referenced	16.8	17.6	18.4	19.2	20	20.8	21.6	22.4	23.2	24
Speed Water Referenced Type	0	0	0	0	0	0	0	0	0	0
Speed Direction	0	0	0	0	0	0	0	0	0	0
Exhaust Gas Temperature (K)	440	455	470	485	500	515	530	545	560	575
Fuel Level (type 0)	21.000%	22.000%	23.000%	24.000%	25.000%	26.000%	27.000%	28.000%	29.000%	30.000%
Tank Capacity (cu-m)	0.2100	0.2200	0.2300	0.2400	0.2500	0.2600	0.2700	0.2800	0.2900	0.3000
Battery Voltage	6.39	6.79	7.19	7.59	7.99	8.39	8.79	9.19	9.59	9.99
Battery Current	96	107	118	129	140	151	162	173	184	195
Battery Case Temperature	239.99	242.49	244.99	247.49	249.99	252.49	254.99	257.49	259.99	262.49
Measurement Date	13761	14417	15072	15727	16383	17038	17693	18348	19004	19659
Measurement Time	18144.2	19008.2	19872.2	20736.2	21600.3	22464.3	23328.3	24192.3	25056.3	25920.3
Total Distance	262500	275000	287500	300000	312500	325000	337500	350000	362500	375000
Distance Since Last Reset	262499	274999	287499	299999	312499	324999	337499	349999	362499	374999



Table 5 - 8 Engine Parameters for Engine Basic Edition (from Step 31 - 40)

Step	31	32	33	34	35	36	37	38	39	40
Engine Boost Pressure (Pa)	155000	160000	165000	170000	175000	180000	185000	190000	195000	200000
Engine tilt/trim	31.00%	32.00%	33.00%	34.00%	35.00%	36.00%	37.00%	38.00%	39.00%	40.00%
Engine oil temp. (k)	278	281	284	287	290	293	296	299	302	305
Engine coolant Pressure (Pa)	124000	128000	132000	136000	140000	144000	148000	152000	156000	160000
Fuel Pressure (Pa)	310000	320000	330000	340000	350000	360000	370000	380000	390000	400000
Engine Load %	38%	39%	40%	42%	43%	44%	45%	47%	48%	49%
Engine Torque %	38%	39%	40%	42%	43%	44%	45%	47%	48%	49%
Speed Water Referenced	24.8	25.6	26.4	27.2	28	28.8	29.6	30.4	31.2	32
Speed Water Referenced Type	0	0	0	0	0	0	0	0	0	0
Speed Direction	0	0	0	0	0	0	0	0	0	0
Exhaust Gas Temperature (K)	590	605	620	635	650	665	680	695	710	725
Fuel Level (type 0)	31.000%	32.000%	33.000%	34.000%	35.000%	36.000%	37.000%	38.000%	39.000%	40.000%
Tank Capacity (cu-m)	0.3100	0.3200	0.3300	0.3400	0.3500	0.3600	0.3700	0.3800	0.3900	0.4000
Battery Voltage	10.39	10.79	11.19	11.59	11.99	12.39	12.79	13.19	13.59	13.99
Battery Current	206	217	228	239	250	261	272	283	294	305
Battery Case Temperature	264.99	267.49	269.99	272.49	274.99	277.49	279.99	282.49	284.99	287.49
Measurement Date	20314	20970	21625	22280	22936	23591	24246	24902	25557	26212
Measurement Time	26784.3	27648.3	28512.3	29376.3	30240.4	31104.4	31968.4	32832.4	33696.4	34560.4
Total Distance	387500	400000	412500	425000	437500	450000	462500	475000	487500	500000
Distance Since Last Reset	387499	399999	412499	424999	437499	449999	462499	474999	487499	499999



Table 5 - 9 Engine Parameters for Engine Basic Edition (from Step 41 - 50)

Step	41	42	43	44	45	46	47	48	49	50
Engine Boost Pressure (Pa)	205000	210000	215000	220000	225000	230000	235000	240000	245000	250000
Engine tilt/trim	41.00%	42.00%	43.00%	44.00%	45.00%	46.00%	47.00%	48.00%	49.00%	50.00%
Engine oil temp. (k)	308	311	314	317	320	323	326	329	332	335
Engine coolant Pressure (Pa)	164000	168000	172000	176000	180000	184000	188000	192000	196000	200000
Fuel Pressure (Pa)	410000	420000	430000	440000	450000	460000	470000	480000	490000	500000
Engine Load %	50%	52%	53%	54%	55%	57%	58%	59%	60%	62%
Engine Torque %	50%	52%	53%	54%	55%	57%	58%	59%	60%	62%
Speed Water Referenced	32.8	33.6	34.4	35.2	36	36.8	37.6	38.4	39.2	40
Speed Water Referenced Type	2	3	4	129	252	253	254	255	1	1
Speed Direction	0	0	0	0	0	0	0	0	0	0
Exhaust Gas Temperature (K)	740	755	770	785	800	815	830	845	860	875
Fuel Level (type 0)	41.000%	42.000%	43.000%	44.000%	45.000%	46.000%	47.000%	48.000%	49.000%	50.000%
Tank Capacity (cu-m)	0.4100	0.4200	0.4300	0.4400	0.4500	0.4600	0.4700	0.4800	0.4900	0.5000
Battery Voltage	14.39	14.79	15.19	15.59	15.99	16.39	16.79	17.19	17.59	17.99
Battery Current	316	327	338	349	360	371	382	393	404	415
Battery Case Temperature	289.99	292.49	294.99	297.49	299.99	302.49	304.99	307.49	309.99	312.49
Measurement Date	26868	27523	28178	28834	29489	30144	30800	31455	32110	32766
Measurement Time	35424.4	36288.4	37152.4	38016.4	38880.5	39744.5	40608.5	41472.5	42336.5	43200.5
Total Distance	512500	525000	537500	550000	562500	575000	587500	600000	612500	625000
Distance Since Last Reset	512499	524999	537499	549999	562499	574999	587499	599999	612499	624999



Table 5 - 10 Engine Parameters for Engine Basic Edition (from Step 51 - 60)

Step	51	52	53	54	55	56	57	58	59	60
Engine Boost Pressure (Pa)	255000	260000	265000	270000	275000	280000	285000	290000	295000	300000
Engine tilt/trim	51.00%	52.00%	53.00%	54.00%	55.00%	56.00%	57.00%	58.00%	59.00%	60.00%
Engine oil temp. (k)	338	341	344	347	350	353	356	359	362	365
Engine coolant Pressure (Pa)	204000	208000	212000	216000	220000	224000	228000	232000	236000	240000
Fuel Pressure (Pa)	510000	520000	530000	540000	550000	560000	570000	580000	590000	600000
Engine Load %	63%	64%	65%	66%	68%	69%	70%	71%	73%	74%
Engine Torque %	63%	64%	65%	66%	68%	69%	70%	71%	73%	74%
Speed Water Referenced	40.8	41.6	42.4	43.2	44	44.8	45.6	46.4	47.2	48
Speed Water Referenced Type	1	1	1	1	1	1	1	1	1	1
Speed Direction	0	0	0	0	0	0	0	0	0	0
Exhaust Gas Temperature (K)	890	905	920	935	950	965	980	995	1010	1025
Fuel Level (type 0)	51.000%	52.000%	53.000%	54.000%	55.000%	56.000%	57.000%	58.000%	59.000%	60.000%
Tank Capacity (cu-m)	0.5100	0.5200	0.5300	0.5400	0.5500	0.5600	0.5700	0.5800	0.5900	0.6000
Battery Voltage	18.39	18.79	19.19	19.59	19.99	20.39	20.79	21.19	21.59	21.99
Battery Current	426	437	448	459	470	481	492	503	514	525
Battery Case Temperature	314.99	317.49	319.99	322.49	324.99	327.49	329.99	332.49	334.99	337.49
Measurement Date	33421	34076	34731	35387	36042	36697	37353	38008	38663	39319
Measurement Time	44064.5	44928.5	45792.5	46656.5	47520.6	48384.6	49248.6	50112.6	50976.6	51840.6
Total Distance	637500	650000	662500	675000	687500	700000	712500	725000	737500	750000
Distance Since Last Reset	637499	649999	662499	674999	687499	699999	712499	724999	737499	749999



Table 5 - 11 Engine Parameters for Engine Basic Edition (from Step 61 - 70)

Step	61	62	63	64	65	66	67	68	69	70
Engine Boost Pressure (Pa)	305000	310000	315000	320000	325000	330000	335000	340000	345000	350000
Engine tilt/trim	61.00%	62.00%	63.00%	64.00%	65.00%	66.00%	67.00%	68.00%	69.00%	70.00%
Engine oil temp. (k)	368	371	374	377	380	383	386	389	392	395
Engine coolant Pressure (Pa)	244000	248000	252000	256000	260000	264000	268000	272000	276000	280000
Fuel Pressure (Pa)	610000	620000	630000	640000	650000	660000	670000	680000	690000	700000
Engine Load %	75%	76%	78%	79%	80%	81%	83%	84%	85%	86%
Engine Torque %	75%	76%	78%	79%	80%	81%	83%	84%	85%	86%
Speed Water Referenced	48.8	49.6	50.4	51.2	52	52.8	53.6	54.4	55.2	56
Speed Water Referenced Type	1	1	1	1	1	1	1	1	1	1
Speed Direction	0	0	0	0	0	0	0	0	0	0
Exhaust Gas Temperature (K)	1040	1055	1070	1085	1100	1115	1130	1145	1160	1175
Fuel Level (type 0)	61.000%	62.000%	63.000%	64.000%	65.000%	66.000%	67.000%	68.000%	69.000%	70.000%
Tank Capacity (cu-m)	0.6100	0.6200	0.6300	0.6400	0.6500	0.6600	0.6700	0.6800	0.6900	0.7000
Battery Voltage	22.39	22.79	23.19	23.59	23.99	24.39	24.79	25.19	25.59	25.99
Battery Current	536	547	558	569	580	591	602	613	624	635
Battery Case Temperature	339.99	342.49	344.99	347.49	349.99	352.49	354.99	357.49	359.99	362.49
Measurement Date	39974	40629	41285	41940	42595	43251	43906	44561	45217	45872
Measurement Time	52704.6	53568.6	54432.6	55296.6	56160.7	57024.7	57888.7	58752.7	59616.7	60480.7
Total Distance	762500	775000	787500	800000	812500	825000	837500	850000	862500	875000
Distance Since Last Reset	762499	774999	787499	799999	812499	824999	837499	849999	862499	874999



Table 5 - 12 Engine Parameters for Engine Basic Edition (from Step 71 - 80)

Step	71	72	73	74	75	76	77	78	79	80
Engine Boost Pressure (Pa)	355000	360000	365000	370000	375000	380000	385000	390000	395000	400000
Engine tilt/trim	71.00%	72.00%	73.00%	74.00%	75.00%	76.00%	77.00%	78.00%	79.00%	80.00%
Engine oil temp. (k)	398	401	404	407	410	413	416	419	422	425
Engine coolant Pressure (Pa)	284000	288000	292000	296000	300000	304000	308000	312000	316000	320000
Fuel Pressure (Pa)	710000	720000	730000	740000	750000	760000	770000	780000	790000	800000
Engine Load %	88%	89%	90%	91%	93%	94%	95%	96%	97%	99%
Engine Torque %	88%	89%	90%	91%	93%	94%	95%	96%	97%	99%
Speed Water Referenced	56.8	57.6	58.4	59.2	60	60.8	61.6	62.4	63.2	64
Speed Water Referenced Type	1	1	1	1	1	1	1	1	1	1
Speed Direction	0	0	0	0	0	0	0	0	0	0
Exhaust Gas Temperature (K)	1190	1205	1220	1235	1250	1265	1280	1295	1310	1325
Fuel Level (type 0)	71.000%	72.000%	73.000%	74.000%	75.000%	76.000%	77.000%	78.000%	79.000%	80.000%
Tank Capacity (cu-m)	0.7100	0.7200	0.7300	0.7400	0.7500	0.7600	0.7700	0.7800	0.7900	0.8000
Battery Voltage	26.39	26.79	27.19	27.59	27.99	28.39	28.79	29.19	29.59	29.99
Battery Current	646	657	668	679	690	701	712	723	734	745
Battery Case Temperature	364.99	367.49	369.99	372.49	374.99	377.49	379.99	382.49	384.99	387.49
Measurement Date	46527	47183	47838	48493	49149	49804	50459	51114	51770	52425
Measurement Time	61344.7	62208.7	63072.7	63936.7	64800.8	65664.8	66528.8	67392.8	68256.8	69120.8
Total Distance	887500	900000	912500	925000	937500	950000	962500	975000	987500	1000000
Distance Since Last Reset	887499	899999	912499	924999	937499	949999	962499	974999	987499	999999



Table 5 - 13 Engine Parameters for Engine Basic Edition (from Step 81 - 88)

Step	81	82	83	84	85	86	87	88
Engine Boost Pressure (Pa)	707600	1015300	1322900	1630600	1938300	2245900	2553600	2861200
Engine tilt/trim	81.00%	82.00%	83.00%	84.00%	85.00%	86.00%	87.00%	88.00%
Engine oil temp. (k)	428	431	434	437	440	847.5	1255	1662.6
Engine coolant Pressure (Pa)	631600	943300	1254900	1566600	1878300	2189900	2501600	2813200
Fuel Pressure (Pa)	4036000	7273000	10509000	13746000	16983000	20219000	23456000	26692000
Engine Load %	100%	101%	102%	104%	105%	106%	107%	109%
Engine Torque %	100%	101%	102%	104%	105%	106%	107%	109%
Speed Water Referenced	93.56	123.13	152.69	182.26	211.83	241.39	270.96	300.52
Speed Water Referenced Type	1	1	1	1	1	1	1	1
Speed Direction	0	0	0	0	0	0	0	0
Exhaust Gas Temperature (K)	1340	1355	1370	1385	1400	2425.147	3450.294	4475.442
Fuel Level (type 0)	81.000%	82.000%	83.000%	84.000%	85.000%	86.000%	87.000%	88.000%
Tank Capacity (cu-m)	21475.5964	42950.3929	64425.1893	85899.9858	107374.7823	128849.5787	150324.3752	171799.1716
Battery Voltage	30.39	30.79	31.19	31.59	31.99	51.69	71.4	91.11
Battery Current	756	767	778	789	800	965	1130.1	1295.2
Battery Case Temperature	389.99	392.49	394.99	397.49	399.99	417.01	434.03	451.05
Measurement Date	53080	53736	54391	55046	55702	56357	57012	57668
Measurement Time	69984.81	70848.82	71712.83	72576.84	73440.85	74304.86	75168.87	76032.88
Total Distance	215698364	430396729	645095093	859793458	1074491823	1289190187	1503888552	1718586916
Distance Since Last Reset	215698363	430396728	645095092	859793457	1074491822	1289190186	1503888551	1718586915



Table 5 - 14 Engine Parameters for Engine Basic Edition (from Step 89 - 96)

Step	89	91	92	93	94	95	96
Engine Boost Pressure (Pa)	3168900	3784200	4091900	4399500	4707200	5014900	5322500
Engine tilt/trim	89.00%	91.00%	92.00%	93.00%	94.00%	95.00%	96.00%
Engine oil temp. (k)	2070.1	2885.2	3292.8	3700.3	4107.9	4515.4	4923
Engine coolant Pressure (Pa)	3124900	3748200	4059900	4371500	4683200	4994900	5306500
Fuel Pressure (Pa)	29929000	36402000	39639000	42875000	46112000	49349000	52585000
Engine Load %	110%	112%	114%	115%	116%	117%	119%
Engine Torque %	110%	112%	114%	115%	116%	117%	119%
Speed Water Referenced	330.09	389.22	418.79	448.35	477.92	507.49	537.05
Speed Water Referenced Type	1	1	1	1	1	1	1
Speed Direction	0	0	0	0	0	0	0
Exhaust Gas Temperature (K)	5500.589	7550.884	8576.032	9601.179	10626.327	11651.474	12676.622
Fuel Level (type 0)	89.000%	91.000%	92.000%	93.000%	94.000%	95.000%	96.000%
Tank Capacity (cu-m)	193273.9681	236223.5610	257698.3575	279173.1539	300647.9504	322122.7469	343597.5433
Battery Voltage	110.82	150.24	169.95	189.66	209.37	229.08	248.79
Battery Current	1460.3	1790.5	1955.6	2120.7	2285.8	2450.9	2616
Battery Case Temperature	468.07	502.11	519.13	536.16	553.18	570.2	587.22
Measurement Date	58323	59634	60289	60944	61600	62255	62910
Measurement Time	76896.89	78624.91	79488.92	80352.93	81216.94	82080.95	82944.96
Total Distance	1933285281	2362682010	2577380375	2792078739	3006777104	3221475469	3436173833
Distance Since Last Reset	1933285280	2362682009	2577380374	2792078738	3006777103	3221475468	3436173832



Table 5 - 15 Engine Parameters for Engine Basic Edition (from Step 97 - 100)

Step	97	98	99	100
Engine Boost Pressure (Pa)	5630200	5937800	6245500	6553200
Engine tilt/trim	97.00%	98.00%	99.00%	100.00%
Engine oil temp. (k)	5330.5	5738.1	6145.6	6553.2
Engine coolant Pressure (Pa)	5618200	5929800	6241500	6553200
Fuel Pressure (Pa)	55822000	59058000	62295000	65532000
Engine Load %	120%	121%	122%	124%
Engine Torque %	120%	121%	122%	124%
Speed Water Referenced	566.62	596.18	625.75	655.32
Speed Water Referenced Type	1	1	1	1
Speed Direction	0	0	0	0
Exhaust Gas Temperature (K)	13701.769	14726.917	15752.064	16777.212
Fuel Level (type 0)	97.000%	98.000%	99.000%	100.000%
Tank Capacity (cu-m)	365072.3398	386547.1362	408021.9327	429496.7292
Battery Voltage	268.5	288.21	307.92	327.64
Battery Current	2781.1	2946.2	3111.3	3276.4
Battery Case Temperature	604.24	621.26	638.28	655.32
Measurement Date	63566	64221	64876	65532
Measurement Time	83808.97	84672.98	85536.99	86401
Total Distance	3650872198	3865570562	4080268927	4294967292
Distance Since Last Reset	3650872197	3865570561	4080268926	4294967292

5.3. Simulation Data for SIMN2000 Engine Premium Edition

Au NMEA 2000 Simulator Engine Premium Edition simulates 28 parameters, including 26 parameters supported by Engine Basic edition, plus 2 Engine Parameters: Engine Discrete Status 1 and Engine Discrete Status 2. Engine Discrete Status vs. control step are summarized in table 5 - 16 and Table 5 - 17

Table 5 - 16 Engine Discrete Status 1 for Engine Premium Edition

Step	Engine Discrete Status 1			
0	0B	00000000	00000001	Check Engine
1	0B	00000000	00000010	Over Temperature
2	0B	00000000	00000100	Low Oil Pressure
3	0B	00000000	00001000	Low Oil Level
4	0B	00000000	00010000	Low Fuel Pressure
5	0B	00000000	00100000	Low System Voltage
6	0B	00000000	01000000	Low Coolant Level



7	0B	00000000	10000000	Water Flow
8	0B	00000001	00000000	Water in Fuel
9	0B	00000010	00000000	Charge Indicator
10	0B	00000100	00000000	Preheat Indicator
11	0B	00001000	00000000	High Boost Pressure
12	0B	00010000	00000000	Rev Limit Exceeded
13	0B	00100000	00000000	EGR System
14	0B	01000000	00000000	Throttle Position Sensor
15	0B	10000000	00000000	Engine Emergency Stop Mode
16 - 31	0B	00000000	00000000	Inactive states
32 - 100	0B	11111111	11111111	All warnings ON

Note: Inactive states shall be transmitted as 0. Reserved and unsupported bits within the field shall be transmitted as 0.

Table 5 - 17 Engine Discrete Status 2 for Engine Premium Edition

Step	Engine Discrete Status 2			
0 - 15	0B	00000000	00000000	Inactive states
16	0B	00000000	00000001	Warning Level 1
17	0B	00000000	00000010	Warning Level 2
18	0B	00000000	00000100	Power Reduction
19	0B	00000000	00001000	Maintenance Needed
20	0B	00000000	00010000	Engine Communication Error
21	0B	00000000	00100000	Sub or Secondary Throttle
22	0B	00000000	01000000	Neutral Start Protect
23	0B	00000000	10000000	Engine Shutting Down
24 - 31	0B	00000001	00000000	reserved
32 - 100	0B	11111111	11111111	All warnings ON

Note: Inactive states shall be transmitted as 0. Reserved and unsupported bits within the field shall be transmitted as 0.

5.4. Simulation Data for SIMN2000 Vessel Platinum Edition

Vessel Platinum edition of Au NMEA 2000 PowerTrain Simulator support all 28 parameters supported by Engine Premium edition, plus the following 21 Vessel Parameters Simulation results of the 21 vessel parameters vs. control step are summarized in Table from 5 - 18 to 5 - 30.

Table 5 - 18 Transmission Discrete Status 2 for Engine Premium Edition

Step	Transmission Discrete Warning Status		
0	0B	00000001	Check Transmission
1	0B	00000010	Over Temperature
2	0B	00000100	Low Oil Pressure
3	0B	00001000	Low Oil Level
4	0B	00010000	Sail Drive
5, 6, 7	0B	00100000	reserved
8 - 100	0B	11111111	All warnings ON



Table 5 - 19 Vessel Parameters for Vessel Platinum Edition (0 - 9)

Step	0	1	2	3	4	5	6	7	8	9
Waste Water Level	0.000%	0.996%	1.996%	2.996%	3.996%	4.996%	5.996%	6.996%	7.996%	8.996%
Waste Water Tank Capacity (cu-m)	0.0000	0.0099	0.0199	0.0299	0.0399	0.0499	0.0599	0.0699	0.0799	0.0899
Black Water Level	0.000%	0.992%	1.992%	2.992%	3.992%	4.992%	5.992%	6.992%	7.992%	8.992%
Black Water Tank Capacity (cu-m)	0.0000	0.0098	0.0198	0.0298	0.0398	0.0498	0.0598	0.0698	0.0798	0.0898
Transmission Gear	2	3	1	0	0	0	0	0	0	0
Transmission Oil Pressure	0	9900	19900	29900	39900	49900	59900	69900	79900	89900
Transmission Oil Temperature	0	39.9	79.9	119.9	159.9	199.9	202.9	205.9	208.9	211.9
Port Trim tab	0	0.01	0.02	0.03	0.04	0.05	0.06	0.07	0.08	0.09
Starboard Trim Tab	1	0.99	0.98	0.97	0.96	0.95	0.94	0.93	0.92	0.91
Rudder Direction Order	000	001	010	111	111	111	111	111	111	111
Angle Order				-3.1416	-3.0769	-3.0121	-2.9473	-2.8825	-2.8178	-2.753
Rudder Position	-3.1416	-3.0788	-3.016	-2.9532	-2.8903	-2.8275	-2.7647	-2.7018	-2.639	-2.5762
Water Depth Transducer	0	2.5	5	7.5	10	12.5	15	17.5	20	22.5
Water Depth Offset	-32.764	-32.109	-31.454	-30.799	-30.143	-29.488	-28.833	-28.178	-27.522	-26.867
Max. depth Range				0	20	50	70	100	120	150
COG Reference	11	10	00	00	00	00	00	00	00	00
Course Over Ground	0	0.0628	0.1256	0.1884	0.2513	0.3141	0.3769	0.4398	0.5026	0.5654
Speed Over Ground	0	0.79	1.59	2.39	3.19	3.99	4.79	5.59	6.39	7.19
Latitude	-90	-88.2	-86.4	-84.6	-82.8	-81	-79.2	-77.4	-75.6	-73.8
Longitude	-180	-176.4	-172.8	-169.2	-165.6	-162	-158.4	-154.8	-151.2	-147.6



Table 5 - 20 Vessel Parameters for Vessel Platinum Edition (10 -18)

Step	10	11	12	13	14	15	16	17	18
Waste Water Level	9.996%	10.996%	11.996%	12.996%	13.996%	14.996%	15.996%	16.996%	17.996%
Waste Water Tank Capacity (cu-m)	0.0999	0.1099	0.1199	0.1299	0.1399	0.1499	0.1599	0.1699	0.1799
Black Water Level	9.992%	10.992%	11.992%	12.992%	13.992%	14.992%	15.992%	16.992%	17.992%
Black Water Tank Capacity (cu-m)	0.0998	0.1098	0.1198	0.1298	0.1398	0.1498	0.1598	0.1698	0.1798
Transmission Gear	0	0	0	0	0	0	0	0	0
Transmission Oil Pressure	99900	109900	119900	129900	139900	149900	159900	169900	179900
Transmission Oil Temperature	214.9	217.9	220.9	223.9	226.9	229.9	232.9	235.9	238.9
Port Trim tab	0.1	0.11	0.12	0.13	0.14	0.15	0.16	0.17	0.18
Starboard Trim Tab	0.9	0.89	0.88	0.87	0.86	0.85	0.84	0.83	0.82
Rudder Direction Order	111	111	111	111	111	111	111	111	111
Angle Order	-2.6882	-2.6234	-2.5587	-2.4939	-2.4291	-2.3643	-2.2996	-2.2348	-2.17
Rudder Position	-2.5133	-2.4505	-2.3877	-2.3248	-2.262	-2.1992	-2.1363	-2.0735	-2.0107
Water Depth Transducer	25	27.5	30	32.5	35	37.5	40	42.5	45
Water Depth Offset	-26.212	-25.556	-24.901	-24.246	-23.591	-22.935	-22.28	-21.625	-20.969
Max. depth Range	180	200	230	250	280	310	330	360	380
COG Reference	00	00	00	00	00	00	00	00	00
Course Over Ground	0.6283	0.6911	0.7539	0.8168	0.8796	0.9424	1.0053	1.0681	1.1309
Speed Over Ground	7.99	8.79	9.59	10.39	11.19	11.99	12.79	13.59	14.39
Latitude	-72	-70.2	-68.4	-66.6	-64.8	-63	-61.2	-59.4	-57.6
Longitude	-144	-140.4	-136.8	-133.2	-129.6	-126	-122.4	-118.8	-115.2



Table 5 - 21 Vessel Parameters for Vessel Platinum Edition (19 -27)

Step	19	20	21	22	23	24	25	26	27
Waste Water Level	18.996%	19.996%	20.996%	21.996%	22.996%	23.996%	24.996%	25.996%	26.996%
Waste Water Tank Capacity (cu-m)	0.1899	0.1999	0.2099	0.2199	0.2299	0.2399	0.2499	0.2599	0.2699
Black Water Level	18.992%	19.992%	20.992%	21.992%	22.992%	23.992%	24.992%	25.992%	26.992%
Black Water Tank Capacity (cu-m)	0.1898	0.1998	0.2098	0.2198	0.2298	0.2398	0.2498	0.2598	0.2698
Transmission Gear	0	0	0	0	0	0	0	0	0
Transmission Oil Pressure	189900	199900	209900	219900	229900	239900	249900	259900	269900
Transmission Oil Temperature	241.9	244.9	247.9	250.9	253.9	256.9	259.9	262.9	265.9
Port Trim tab	0.19	0.2	0.21	0.22	0.23	0.24	0.25	0.26	0.27
Starboard Trim Tab	0.81	0.8	0.79	0.78	0.77	0.76	0.75	0.74	0.73
Rudder Direction Order	111	111	111	111	111	111	111	111	111
Angle Order	-2.1052	-2.0405	-1.9757	-1.9109	-1.8461	-1.7814	-1.7166	-1.6518	-1.587
Rudder Position	-1.9478	-1.885	-1.8222	-1.7593	-1.6965	-1.6337	-1.5708	-1.508	-1.4452
Water Depth Transducer	47.5	50	52.5	55	57.5	60	62.5	65	67.5
Water Depth Offset	-20.314	-19.659	-19.004	-18.348	-17.693	-17.038	-16.382	-15.727	-15.072
Max. depth Range	410	440	460	490	510	540	570	590	620
COG Reference	00	00	00	00	00	00	00	00	00
Course Over Ground	1.1938	1.2566	1.3194	1.3823	1.4451	1.5079	1.5708	1.6336	1.6964
Speed Over Ground	15.19	15.99	16.79	17.59	18.39	19.19	19.99	20.79	21.59
Latitude	-55.8	-54	-52.2	-50.4	-48.6	-46.8	-45	-43.2	-41.4
Longitude	-111.6	-108	-104.4	-100.8	-97.2	-93.6	-90	-86.4	-82.8



Table 5 - 22 Vessel Parameters for Vessel Platinum Edition (28 -36)

Step	28	29	30	31	32	33	34	35	36
Waste Water Level	27.996%	28.996%	29.996%	30.996%	31.996%	32.996%	33.996%	34.996%	35.996%
Waste Water Tank Capacity (cu-m)	0.2799	0.2899	0.2999	0.3099	0.3199	0.3299	0.3399	0.3499	0.3599
Black Water Level	27.992%	28.992%	29.992%	30.992%	31.992%	32.992%	33.992%	34.992%	35.992%
Black Water Tank Capacity (cu-m)	0.2798	0.2898	0.2998	0.3098	0.3198	0.3298	0.3398	0.3498	0.3598
Transmission Gear	0	0	0	0	0	0	0	0	0
Transmission Oil Pressure	279900	289900	299900	309900	319900	329900	339900	349900	359900
Transmission Oil Temperature	268.9	271.9	274.9	277.9	280.9	283.9	286.9	289.9	292.9
Port Trim tab	0.28	0.29	0.3	0.31	0.32	0.33	0.34	0.35	0.36
Starboard Trim Tab	0.72	0.71	0.7	0.69	0.68	0.67	0.66	0.65	0.64
Rudder Direction Order	111	111	111	111	111	111	111	111	111
Angle Order	-1.5223	-1.4575	-1.3927	-1.3279	-1.2632	-1.1984	-1.1336	-1.0688	-1.0041
Rudder Position	-1.3824	-1.3195	-1.2567	-1.1939	-1.131	-1.0682	-1.0054	-0.9425	-0.8797
Water Depth Transducer	70	72.5	75	77.5	80	82.5	85	87.5	90
Water Depth Offset	-14.417	-13.761	-13.106	-12.451	-11.796	-11.14	-10.485	-9.83	-9.174
Max. depth Range	640	670	700	720	750	770	800	830	850
COG Reference	00	00	00	00	00	00	00	00	00
Course Over Ground	1.7592	1.8221	1.8849	1.9477	2.0106	2.0734	2.1362	2.1991	2.2619
Speed Over Ground	22.39	23.19	23.99	24.79	25.59	26.39	27.19	27.99	28.79
Latitude	-39.6	-37.8	-36	-34.2	-32.4	-30.6	-28.8	-27	-25.2
Longitude	-79.2	-75.6	-72	-68.4	-64.8	-61.2	-57.6	-54	-50.4



Table 5 - 23 Vessel Parameters for Vessel Platinum Edition (37 -46)

Step	37	38	39	40	41	42	43	44	45	46
Waste Water Level	36.996%	37.996%	38.996%	39.996%	40.996%	41.996%	42.996%	43.996%	44.996%	45.996%
Waste Water Tank Capacity (cu-m)	0.3699	0.3799	0.3899	0.3999	0.4099	0.4199	0.4299	0.4399	0.4499	0.4599
Black Water Level	36.992%	37.992%	38.992%	39.992%	40.992%	41.992%	42.992%	43.992%	44.992%	45.992%
Black Water Tank Capacity (cu-m)	0.3698	0.3798	0.3898	0.3998	0.4098	0.4198	0.4298	0.4398	0.4498	0.4598
Transmission Gear	0	0	0	0	0	0	0	0	0	0
Transmission Oil Pressure	369900	379900	389900	399900	409900	419900	429900	439900	449900	459900
Transmission Oil Temperature	295.9	298.9	301.9	304.9	307.9	310.9	313.9	316.9	319.9	322.9
Port Trim tab	0.37	0.38	0.39	0.4	0.41	0.42	0.43	0.44	0.45	0.46
Starboard Trim Tab	0.63	0.62	0.61	0.6	0.59	0.58	0.57	0.56	0.55	0.54
Rudder Direction Order	111	111	111	111	111	111	111	111	111	111
Angle Order	-0.9393	-0.8745	-0.8097	-0.745	-0.6802	-0.6154	-0.5506	-0.4859	-0.4211	-0.3563
Rudder Position	-0.8169	-0.754	-0.6912	-0.6284	-0.5655	-0.5027	-0.4399	-0.377	-0.3142	-0.2514
Water Depth Transducer	92.5	95	97.5	100	102.5	105	107.5	110	112.5	115
Water Depth Offset	-8.519	-7.864	-7.209	-6.553	-5.898	-5.243	-4.587	-3.932	-3.277	-2.622
Max. depth Range	880	900	930	960	980	1010	1030	1060	1090	1110
COG Reference	00	00	00	00	00	00	00	00	00	00
Course Over Ground	2.3247	2.3876	2.4504	2.5132	2.5761	2.6389	2.7017	2.7646	2.8274	2.8902
Speed Over Ground	29.59	30.39	31.19	31.99	32.79	33.59	34.39	35.19	35.99	36.79
Latitude	-23.4	-21.6	-19.8	-18	-16.2	-14.4	-12.6	-10.8	-9	-7.2
Longitude	-46.8	-43.2	-39.6	-36	-32.4	-28.8	-25.2	-21.6	-18	-14.4



Table 5 - 24 Vessel Parameters for Vessel Platinum Edition (47 -55)

Step	47	48	49	50	51	52	53	54	55
Waste Water Level	46.996%	47.996%	48.996%	49.996%	50.996%	51.996%	52.996%	53.996%	54.996%
Waste Water Tank Capacity (cu-m)	0.4699	0.4799	0.4899	0.4999	0.5099	0.5199	0.5299	0.5399	0.5499
Black Water Level	46.992%	47.992%	48.992%	49.992%	50.992%	51.992%	52.992%	53.992%	54.992%
Black Water Tank Capacity (cu-m)	0.4698	0.4798	0.4898	0.4998	0.5098	0.5198	0.5298	0.5398	0.5498
Transmission Gear	0	0	0	0	0	0	0	0	0
Transmission Oil Pressure	469900	479900	489900	499900	509900	519900	529900	539900	549900
Transmission Oil Temperature	325.9	328.9	331.9	334.9	337.9	340.9	343.9	346.9	349.9
Port Trim tab	0.47	0.48	0.49	0.5	0.51	0.52	0.53	0.54	0.55
Starboard Trim Tab	0.53	0.52	0.51	0.5	0.49	0.48	0.47	0.46	0.45
Rudder Direction Order	111	111	111	111	111	111	111	111	111
Angle Order	-0.2915	-0.2268	-0.162	-0.0972	-0.0324	0.0323	0.0971	0.1619	0.2267
Rudder Position	-0.1885	-0.1257	-0.0629	0	0.0628	0.1256	0.1884	0.2513	0.3141
Water Depth Transducer	117.5	120	122.5	125	127.5	130	132.5	135	137.5
Water Depth Offset	-1.966	-1.311	-0.656	0	0.655	1.31	1.965	2.621	3.276
Max. depth Range	1140	1160	1190	1220	1240	1270	1290	1320	1350
COG Reference	00	00	00	00	01	01	01	01	01
Course Over Ground	2.9531	3.0159	3.0787	3.1416	3.2044	3.2672	3.33	3.3929	3.4557
Speed Over Ground	37.59	38.39	39.19	39.99	40.79	41.59	42.39	43.19	43.99
Latitude	-5.4	-3.6	-1.8	0	1.8	3.6	5.4	7.2	9
Longitude	-10.8	-7.2	-3.6	0	3.6	7.2	10.8	14.4	18



Table 5 - 25 Vessel Parameters for Vessel Platinum Edition (56 -65)

Step	56	57	58	59	60	61	62	63	64	65
Waste Water Level	55.996%	56.996%	57.996%	58.996%	59.996%	60.996%	61.996%	62.996%	63.996%	64.996%
Waste Water Tank Capacity (cu-m)	0.5599	0.5699	0.5799	0.5899	0.5999	0.6099	0.6199	0.6299	0.6399	0.6499
Black Water Level	55.992%	56.992%	57.992%	58.992%	59.992%	60.992%	61.992%	62.992%	63.992%	64.992%
Black Water Tank Capacity (cu-m)	0.5598	0.5698	0.5798	0.5898	0.5998	0.6098	0.6198	0.6298	0.6398	0.6498
Transmission Gear	0	0	0	0	0	0	0	0	0	0
Transmission Oil Pressure	559900	569900	579900	589900	599900	609900	619900	629900	639900	649900
Transmission Oil Temperature	352.9	355.9	358.9	361.9	364.9	367.9	370.9	373.9	376.9	379.9
Port Trim tab	0.56	0.57	0.58	0.59	0.6	0.61	0.62	0.63	0.64	0.65
Starboard Trim Tab	0.44	0.43	0.42	0.41	0.4	0.39	0.38	0.37	0.36	0.35
Rudder Direction Order	111	111	111	111	111	111	111	111	111	111
Angle Order	0.2914	0.3562	0.421	0.4858	0.5505	0.6153	0.6801	0.7449	0.8096	0.8744
Rudder Position	0.3769	0.4398	0.5026	0.5654	0.6283	0.6911	0.7539	0.8168	0.8796	0.9424
Water Depth Transducer	140	142.5	145	147.5	150	152.5	155	157.5	160	162.5
Water Depth Offset	3.931	4.586	5.242	5.897	6.552	7.208	7.863	8.518	9.173	9.829
Max. depth Range	1370	1400	1420	1450	1480	1500	1530	1550	1580	1610
COG Reference	01	01	01	01	01	01	01	01	01	01
Course Over Ground	3.5185	3.5814	3.6442	3.707	3.7699	3.8327	3.8955	3.9584	4.0212	4.084
Speed Over Ground	44.79	45.59	46.39	47.19	47.99	48.79	49.59	50.39	51.19	51.99
Latitude	10.8	12.6	14.4	16.2	18	19.8	21.6	23.4	25.2	27
Longitude	21.6	25.2	28.8	32.4	36	39.6	43.2	46.8	50.4	54



Table 5 - 26 Vessel Parameters for Vessel Platinum Edition (66 -75)

Step	66	67	68	69	70	71	72	73	74	75
Waste Water Level	65.996%	66.996%	67.996%	68.996%	69.996%	70.996%	71.996%	72.996%	73.996%	74.996%
Waste Water Tank Capacity (cu-m)	0.6599	0.6699	0.6799	0.6899	0.6999	0.7099	0.7199	0.7299	0.7399	0.7499
Black Water Level	65.992%	66.992%	67.992%	68.992%	69.992%	70.992%	71.992%	72.992%	73.992%	74.992%
Black Water Tank Capacity (cu-m)	0.6598	0.6698	0.6798	0.6898	0.6998	0.7098	0.7198	0.7298	0.7398	0.7498
Transmission Gear	0	0	0	0	0	0	0	0	0	0
Transmission Oil Pressure	659900	669900	679900	689900	699900	709900	719900	729900	739900	749900
Transmission Oil Temperature	382.9	385.9	388.9	391.9	394.9	397.9	400.9	403.9	406.9	409.9
Port Trim tab	0.66	0.67	0.68	0.69	0.7	0.71	0.72	0.73	0.74	0.75
Starboard Trim Tab	0.34	0.33	0.32	0.31	0.3	0.29	0.28	0.27	0.26	0.25
Rudder Direction Order	111	111	111	111	111	111	111	111	111	111
Angle Order	0.9392	1.004	1.0687	1.1335	1.1983	1.2631	1.3278	1.3926	1.4574	1.5222
Rudder Position	1.0053	1.0681	1.1309	1.1938	1.2566	1.3194	1.3823	1.4451	1.5079	1.5708
Water Depth Transducer	165	167.5	170	172.5	175	177.5	180	182.5	185	187.5
Water Depth Offset	10.484	11.139	11.795	12.45	13.105	13.76	14.416	15.071	15.726	16.382
Max. depth Range	1630	1660	1680	1710	1740	1760	1790	1810	1840	1870
COG Reference	01	01	01	01	01	01	01	01	01	01
Course Over Ground	4.1469	4.2097	4.2725	4.3354	4.3982	4.461	4.5239	4.5867	4.6495	4.7124
Speed Over Ground	52.79	53.59	54.39	55.19	55.99	56.79	57.59	58.39	59.19	59.99
Latitude	28.8	30.6	32.4	34.2	36	37.8	39.6	41.4	43.2	45
Longitude	57.6	61.2	64.8	68.4	72	75.6	79.2	82.8	86.4	90



Table 5 - 27 Vessel Parameters for Vessel Platinum Edition (76 -83)

Step	76	77	78	79	80	81	82	83
Waste Water Level	75.996%	76.996%	77.996%	78.996%	79.996%	80.996%	81.996%	82.996%
Waste Water Tank Capacity (cu-m)	0.7599	0.7699	0.7799	0.7899	0.7999	21475.5963	42950.3928	64425.1892
Black Water Level	75.992%	76.992%	77.992%	78.992%	79.992%	80.992%	81.992%	82.992%
Black Water Tank Capacity (cu-m)	0.7598	0.7698	0.7798	0.7898	0.7998	21475.5962	42950.3927	64425.1891
Transmission Gear	0	0	0	0	0	0	0	0
Transmission Oil Pressure	759900	769900	779900	789900	799900	1087500	1375200	1662800
Transmission Oil Temperature	412.9	415.9	418.9	421.9	424.9	427.9	430.9	433.9
Port Trim tab	0.76	0.77	0.78	0.79	0.8	0.81	0.82	0.83
Starboard Trim Tab	0.24	0.23	0.22	0.21	0.2	0.19	0.18	0.17
Rudder Direction Order	111	111	111	111	111	111	111	111
Angle Order	1.5869	1.6517	1.7165	1.7813	1.846	1.9108	1.9756	2.0404
Rudder Position	1.6336	1.6964	1.7592	1.8221	1.8849	1.9477	2.0106	2.0734
Water Depth Transducer	190	192.5	195	197.5	200	2147673.6	4295147.3	6442620.9
Water Depth Offset	17.037	17.692	18.347	19.003	19.658	20.313	20.968	21.624
Max. depth Range	1890	1920	1940	1970	2000	2020	2050	2070
COG Reference	01	01	01	01	01	01	01	01
Course Over Ground	4.7752	4.838	4.9008	4.9637	5.0265	5.0893	5.1522	5.215
Speed Over Ground	60.79	61.59	62.39	63.19	63.99	93.55	123.12	152.68
Latitude	46.8	48.6	50.4	52.2	54	55.8	57.6	59.4
Longitude	93.6	97.2	100.8	104.4	108	111.6	115.2	118.8



Table 5 - 28 Vessel Parameters for Vessel Platinum Edition (84 -90)

Step	84	85	86	87	88	89	90
Waste Water Level	83.996%	84.996%	85.996%	86.996%	87.996%	88.996%	89.996%
Waste Water Tank Capacity (cu-m)	85899.9857	107374.7822	128849.5786	150324.3751	171799.1715	193273.9680	214748.7645
Black Water Level	83.992%	84.992%	85.992%	86.992%	87.992%	88.992%	89.992%
Black Water Tank Capacity (cu-m)	85899.9856	107374.7821	128849.5785	150324.3750	171799.1714	193273.9679	214748.7644
Transmission Gear	0	0	0	0	0	0	0
Transmission Oil Pressure	1950500	2238200	2525800	2813500	3101100	3388800	3676500
Transmission Oil Temperature	436.9	439.9	847.4	1254.9	1662.5	2070	2477.6
Port Trim tab	0.84	0.85	0.86	0.87	0.88	0.89	0.9
Starboard Trim Tab	0.16	0.15	0.14	0.13	0.12	0.11	0.1
Rudder Direction Order	111	111	111	111	111	111	111
Angle Order	2.1051	2.1699	2.2347	2.2995	2.3642	2.429	2.4938
Rudder Position	2.1362	2.1991	2.2619	2.3247	2.3876	2.4504	2.5132
Water Depth Transducer	8590094.6	10737568.2	12885041.9	15032515.5	17179989.2	19327462.8	21474936.5
Water Depth Offset	22.279	22.934	23.59	24.245	24.9	25.555	26.211
Max. depth Range	2100	2130	2150	2180	2200	2230	2260
COG Reference	01	01	01	01	01	01	01
Course Over Ground	5.2778	5.3407	5.4035	5.4663	5.5292	5.592	5.6548
Speed Over Ground	182.25	211.82	241.38	270.95	300.51	330.08	359.65
Latitude	61.2	63	64.8	66.6	68.4	70.2	72
Longitude	122.4	126	129.6	133.2	136.8	140.4	144



Table 5 - 29 Vessel Parameters for Vessel Platinum Edition (91 -96)

Step	91	92	93	94	95	96
Waste Water Level	90.996%	91.996%	92.996%	93.996%	94.996%	95.996%
Waste Water Tank Capacity (cu-m)	236223.5609	257698.3574	279173.1538	300647.9503	322122.7468	343597.5432
Black Water Level	90.992%	91.992%	92.992%	93.992%	94.992%	95.992%
Black Water Tank Capacity (cu-m)	236223.5608	257698.3573	279173.1537	300647.9502	322122.7467	343597.5431
Transmission Gear	0	0	0	0	0	0
Transmission Oil Pressure	3964100	4251800	4539400	4827100	5114800	5402400
Transmission Oil Temperature	2885.1	3292.7	3700.2	4107.8	4515.3	4922.9
Port Trim tab	0.91	0.92	0.93	0.94	0.95	0.96
Starboard Trim Tab	0.09	0.08	0.07	0.06	0.05	0.04
Rudder Direction Order	111	111	111	111	111	111
Angle Order	2.5586	2.6233	2.6881	2.7529	2.8177	2.8824
Rudder Position	2.5761	2.6389	2.7017	2.7646	2.8274	2.8902
Water Depth Transducer	23622410.1	25769888.8	27917357.4	30064831	32212304.7	34359778.3
Water Depth Offset	26.866	27.521	28.177	28.832	29.487	30.142
Max. depth Range	2280	2310	2330	2360	2390	2410
COG Reference	01	01	01	01	01	01
Course Over Ground	5.7177	5.7805	5.8433	5.9062	5.969	6.0318
Speed Over Ground	389.21	418.78	448.34	477.91	507.48	537.04
Latitude	73.8	75.6	77.4	79.2	81	82.8
Longitude	147.6	151.2	154.8	158.4	162	165.6



Table 5 - 30 Vessel Parameters for Vessel Platinum Edition (97 -100)

Step	95	96	97	98	99	100
Waste Water Level	94.996%	95.996%	96.996%	97.996%	98.996%	100.000%
Waste Water Tank Capacity (cu-m)	322122.7468	343597.5432	365072.3397	386547.1361	408021.9326	429496.7292
Black Water Level	94.992%	95.992%	96.992%	97.992%	98.992%	100.000%
Black Water Tank Capacity (cu-m)	322122.7467	343597.5431	365072.3396	386547.1360	408021.9325	429496.7292
Transmission Gear *	0	0	0	0	0	0
Transmission Oil Pressure	5114800	5402400	5690100	5977700	6265400	6553200
Transmission Oil Temperature	4515.3	4922.9	5330.4	5738	6145.5	6553.2
Port Trim tab	0.95	0.96	0.97	0.98	0.99	1
Starboard Trim Tab	0.05	0.04	0.03	0.02	0.01	0
Rudder Direction Order	111	111	111	111	111	111
Angle Order	2.8177	2.8824	2.9472	3.012	3.0768	3.1416
Rudder Position	2.8274	2.8902	2.9531	3.0159	3.0787	3.1416
Water Depth Transducer	32212304.7	34359778.3	36507252	38654725.6	40802199.3	42949672.9
Water Depth Offset	29.487	30.142	30.798	31.453	32.108	32.764
Max. depth Range	2390	2410	2440	2460	2490	2520
COG Reference	01	01	01	01	01	01
Course Over Ground	5.969	6.0318	6.0947	6.1575	6.2203	6.2832
Speed Over Ground	507.48	537.04	566.61	596.17	625.74	655.32
Latitude	81	82.8	84.6	86.4	88.2	90
Longitude	162	165.6	169.2	172.8	176.4	180

Note: Transmission Gear: 0 = Forward, 1 = Neutral, 2 = Reverse, 3 = [Unavailable, Unknown].