

Au SAE J1939 Simulator Gen II 2.00A User Manual

Rev. E

Au Group Electronics

July 2020

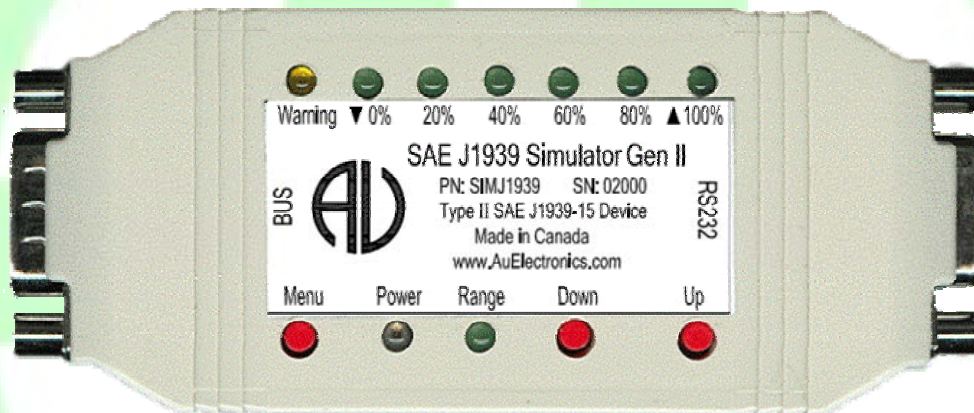



Table of Contents

Table of Contents	2
Chapter 1 Introduction	3
1.1. J1939-15 Network Topology with Au J1939 Simulator.....	3
1.2. Major Hardware Features	3
1.3. Major Operating Features	5
1.4. Six Editions of Au SAE J1939 Simulators 2.00A	6
1.5. Major Operating Features	6
1.6. Basic Functions of Each Edition.....	6
1.7. License /Software Code Upgrade and Support Service.....	7
Chapter 2 Supported SAE J1939 Parameters	8
2.1. Engine Basic Edition(S)	8
2.2. Engine Premium Edition(S).....	9
2.3. Vehicle Platinum Edition(S).....	9
Chapter 3 Operating Instructions	10
3.1. Power On	10
3.2. Operating Modes (Static/Dynamic)	10
3.3. Push Button Functions.....	10
3.4. LED Indicator Status	12
Chapter 4 Au J1939 Simulator Remote Terminal	15
4.1. Step 1: Connect To J1939 Simulator	17
4.2. Step 2: Remote Control the J1939 Simulator	18
4.3. Display Panel – Engine Idle Shutdown (Is).....	19
4.4. Display Panel – Engine Protection System (EPS)	19
4.5. Display Panel – A/C & Refrigerant Switch	19
4.6. Display Panel – Engine Info and Warning Lamps	20
4.7. Display Panel – Abs Info and Warning Lamps	20
4.8. Display Panel – Transmission Info and Warning Lamps	20
4.9. Display Panel – Engine Basic Parameters	21
4.10. Display Panel – Engine DM1	21
4.11. Display Panel – Engine DM2	22
4.12. Display Panel – Engine Configuration	24
4.13. Display Panel – Abs DM1	25
4.14. Display Panel – Transmission Dm1	25
Chapter 5 Data Configuration	26
Appendix A - Remote Terminal Installation Guide.....	40
Appendix B - License Management Toolset	42
Appendix C - Au PIC Serial Bootloader Application Note.....	46
C-1 What’s needed Before Install Au PIC Bootloader?	46
C-2 How to Install Au PIC Bootloader.....	46
C-3 How to Use Au PIC Bootloader	47
Appendix D - CAN Baud Rate Configuration Procedure.....	50

Chapter 1 Introduction

Au SAE J1939 Simulator (Gen II) 2.00A (Figure 1-1), a family of well designed devices, are capable of simulating majority of SAE J1939 signals on a vehicle network.



Figure 1-1 Au J1939 Simulator Gen II

1.1. J1939-15 Network Topology with Au J1939 Simulator

A typical SAE J1939-15 network topology with Au SAE J1939 Simulator is illustrated in Figure 1-2.

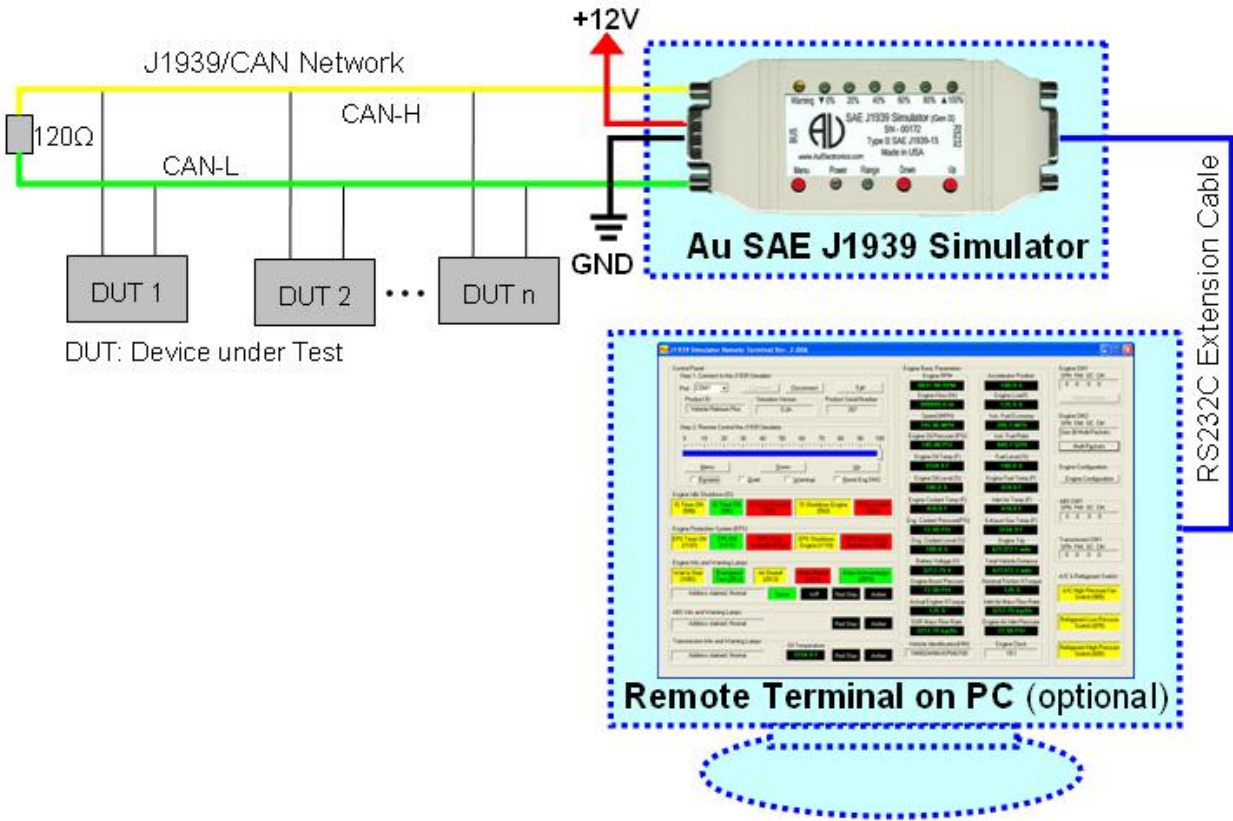

Figure 1-2 Typical SAE J1939-15 network topology for Au J1939 Simulator(s)

1.2. Major Hardware Features

- **SAE J1939-15 Type II ECU:** contain an internal 120 ohm load resistor for easy network setup
- **TVS (Transient Voltage Suppressor) protection** on CAN bus
- **Compact size:** 4-1/8" L X 1-3/4"W X 7/8"H
- **Enclosure color:** Black or PC white
- **Operating temperature:** -4 °F to 185 °F (-20 °C to 85 °C)
- **Power supply:** +12V DC nominal, 250mA max
- **9 LED indicators:** Power, Range, Warning, ▼0%, 20%, 40%, 60%, 80%, ▲100%
- **1 buzzer**
- **3 push buttons:** simulated SAE J1939 signals can be adjusted by 3 push buttons: Menu, Down, Up
- **1 DB9 Male "BUS" Interface:** for power supply and CAN/J1939 network connection (Figure 1-3)
- **1 RS232 interface:** for in field firmware update, license management, and computer remote control (Plus editions only).



Pin 1: GND **Pin 6: CAN-L**
Pin 5: +12V DC **Pin 7: CAN-H**



Pin 2: To PC RXD **Pin 3: from PC TXD**
Pin 5: GND

Figure 1 - 3 Pin-out for BUS side DB9 male connector

Figure 1 - 4 Pin-out for RS232 side DB9 female connector

Au J1939 Simulator plus edition can be connected to a PC either through RS232 port or USB port.

Au J1939 Simulator plus edition can be connected to a PC through RS232 serial port using RS232 serial extension cable (part # CBL-RS232-01), as shown in Figure 1 - 5.



Figure 1-5 Connection of Au J1939 Simulator (Gen II) plus editions to PC with RS232 port

Au J1939 Simulator plus edition can be connected to a PC through USB port using USB to RS232 serial convert cable (part # CBL-USB-232), as shown in Figure 1 - 6.



Figure 1-6 Connection of Au J1939 Simulator (Gen II) plus editions to PC with USB port

The following cables and power supply are optional components for different application, they are sold separately.

Table 1-1 Necessary accessories for Au J1939 Simulator

<p>CBL-CAN-485-01</p>	<p>A 6-wire color coded cable which can be used for Au J1939 devices and Au J1708 devices.</p> <p>One end of the cable is DB9 female connector; it is designed to mate with Au devices on BUS side.</p> <p>The other side of the cable is a pig tail with 3 pairs of twisted color coded wires:</p> <p>Red wire: Power supply, e.g. +12V DC Black wire: Ground Yellow wire: CAN High Green wire: CAN Low Violet: J1708A+ Brown: J1708B-</p>
-----------------------	--

<p>CBL-CAN-485-02D</p> 	<p>CBL-CAN-485-02D is a CAN/J1939/J1708/J1587 cable equipped with a DB9 female connector, dual SAE 9-way Receptacles (green for 500K and black for 250K CAN baud rate) and Power Jacket.</p> <p>The "CBL-CAN-485-02D" is an upgrade version of "CBL-CAN-485-02 and CBL-CAN-485-02G".</p> <p>This CAN/J1939/J1708/J1587 cable provides power supply, J1708/J1587 and CAN network connection similar to what's available on trucks, RVs and School buses.</p> <p>Weight: 125 gram</p> <p>Maximum current: 4A (continuous)</p> <p>Maximum voltage: 300V DC</p>
<p>PWR-912V-CP</p> 	<p>Wall mount AC/DC power supply can supply power to all devices connected to CBL-CAN-485-02D.</p> <p>Specification:</p> <ul style="list-style-type: none"> * Positive center * Connector style: 2.1mm I.D. x 5.5mm O.D. x 12mm Female (compatible with the power jacket of CBL-J1708-02 and CBL-CAN-485-02) * Voltage input: 110~120V AC Input * Voltage output: 14V DC * Current output: 500mA Max. * Inrush current: 40A Maximum * Power: 6.0W * Line Regulation: +/- 2% * Load Regulation: +/- 5%
<p>CBL-RS232-01</p> 	<p>RS232 Serial Extension Cable can be used to connect computer Serial port to Au J1939 / J1708 products (on RS232 Side).</p> <p>Major Features:</p> <ul style="list-style-type: none"> * Fully shielded to prevent unwanted EMI/RFI interference * Fully molded connectors with thumbscrews provide a quick and easy connection every time * Connectors: DB9 Male to DB9 Female * All 9 connector pins are wired straight through
<p>CBL-USB-232</p> 	<p>The USB to Serial Converter cable can be used to connect computer USB port to Au J1939 / J1708 products (on RS232 Side). It acts as a bridge between a USB port and a standard Serial (RS232) port.</p> <p>It is Vista, Win7, and XP compatible.</p> <p>Three LED are included, Power, TX and RX. Power LED is on when USB power is supplied. TX LED will blink when COM port is transmitting. RX LED will blink when COM port is receiving.</p> <p>It is compatible with all Au Group Electronics system products, J1939 Simulators, J1708 Simulators, FMS Simulators, J1939 Interpreters, J1708 Interpreters, J1939 MCS, and J1939 DCS.</p>

1.3. Major Operating Features

- **Smart features:** Recall last operating mode at power-on, capable of generating dynamic data, etc.
- **Ease of use:** No software setup experience or CAN protocol configuration skill is required. After a network is physically connected, apply power supply, it will dynamically generate J1939 data when in dynamic mode.
- **Static Mode and Dynamic Mode**
 - Static mode output static J1939 signals, they can be changed manually
 - Dynamic mode automatically change the output value of SAE J1939 signals



- Two modes can be switched easily (*by Press and hold both **Menu** and **Up** buttons until a long beep is heard*)
- **PC Remote Terminal GUI (for "Plus" editions only):** Display simulated J1939 signal on a computer screen
- **All push button control functions are available on PC Remote Terminal GUI for "Plus" editions only**
- **Easy in-field license upgrade feature** with Au License Management Toolset.
- **In-field firmware update capability**
- **Annual support and minor upgrade services are available**
- **Custom design is available upon request**

1.4. Six Editions of Au SAE J1939 Simulators 2.00A

Six editions of Au SAE J1939 simulator (Gen II) 2.00A are provided to meet various users' needs (3 non-plus editions and 3 plus editions). The **Plus** editions have all the functions of **non-Plus** editions, plus a **PC Remote Terminal** program, which can be used to control and display detail information of simulated SAE J1939 signals on a PC screen (detail information is available in chapter 4.)

Plus Edition = Non-plus Edition + PC Remote Terminal Program

This document will introduce major hardware features, important parameters, operating instruction, remote terminal program and data configuration for all 6 editions of Au SAE J1939 Simulators (Gen II) 2.00A.

The part # for 6 editions of Au SAE J1939 simulator Gen II 2.00A and required accessories are listed in Table 1-1

Table 1-1 Part # for Au SAE J1939 simulator (**Gen II**) **2.00A** and necessary accessories

Au SAE J1939 Simulator Gen II 2.00A, Accessories, and Service		Part #
Non-Plus Edition	Au J1939 Simulator (Gen II 2.00A) Engine Basic Edition	SIMJ1939-007
	Au J1939 Simulator (Gen II 2.00A) Engine Premium Edition	SIMJ1939-008
	Au J1939 Simulator (Gen II 2.00A) Vehicle Platinum Edition	SIMJ1939-009
Plus Edition	Au J1939 Simulator (Gen II 2.00A) Engine Basic Plus Edition	SIMJ1939-010
	Au J1939 Simulator (Gen II 2.00A) Engine Premium Plus Edition	SIMJ1939-011
	Au J1939 Simulator (Gen II 2.00A) Vehicle Platinum Plus Edition	SIMJ1939-012
Service	1 year support and minor upgrades for Au J1939 Simulator	SVS-SIM-J1939

1.5. Major Operating Features

- **Smart features:** Recall last operating mode at power-on, capable of generating dynamic data, etc.
- **Ease of use:** Easy-to-operate design with production line operator and sales person in mind. No software setup experience or CAN protocol configuration skill is required. After a network is physically connected, it will dynamically generate J1939 data when it enters dynamic mode.
- **Static mode and dynamic mode:**
 - Static mode output static J1939 signal. In this mode, signal can be changed manually
 - Dynamic mode automatically changes the output value of SAE J1939 signal
 - Two modes can be switched easily
- **"Remote Terminal" software available** ("Plus" editions only): Display simulated J1939 signal on a computer screen.
- **All push button control functions are available on PC "Remote Terminal" software** ("Plus" editions only)
- **Easy in-field license upgrade feature** with Au License Management Tool. The Basic Edition(s) and Premium Edition(s) can be easily upgraded to Platinum Edition(s)
- **In-field firmware update capability** for minor upgrades (SVS-SIM-J1939) and major upgrades (FIRJ1939-00x)
- **Annual support and minor upgrade services** are available (SVS-SIM-J1939)
- **Major firmware upgrade capability available** (FIRJ1939-00x)
- **Custom design is available upon request**

1.6. Basic Functions of Each Edition

Engine Basic Edition(s):

- "Statically" or "dynamically" generate most of the basic engine data
- Push buttons (**Up** & **Down**) are used in "static mode" to adjust data outputs

- In "dynamic mode", data cycles automatically in its SAE defined range
- LEDs indicate the control step value and reflect push button operations
- Buzzer sound also reflects push button inputs, and can be enabled/disabled

Engine Premium Edition(s):

- Includes all Engine Basic Edition functions
- Plus water in fuel indicator On/Off control
- Plus Premium features on SAE J1939 Transport Protocols with the following diagnostic messages:
 - Engine DM1/DM2 warnings (support single packet and multi-packets)
 - Engine “Red Stop” and “Amber” lamp warnings
 - Engine DM3

Vehicle Platinum Edition(s):

- Includes all Engine Premium Edition functions
- Plus Vehicle Network features (3 controller applications have been implemented):
 - ABS related signals
 - Transmission related signals
 - Engine Configurations

1.7. License /Software Code Upgrade and Support Service

License upgrading and annual service for the 6 editions of SAE J1939 Simulator are summarized in Figure 1-5.

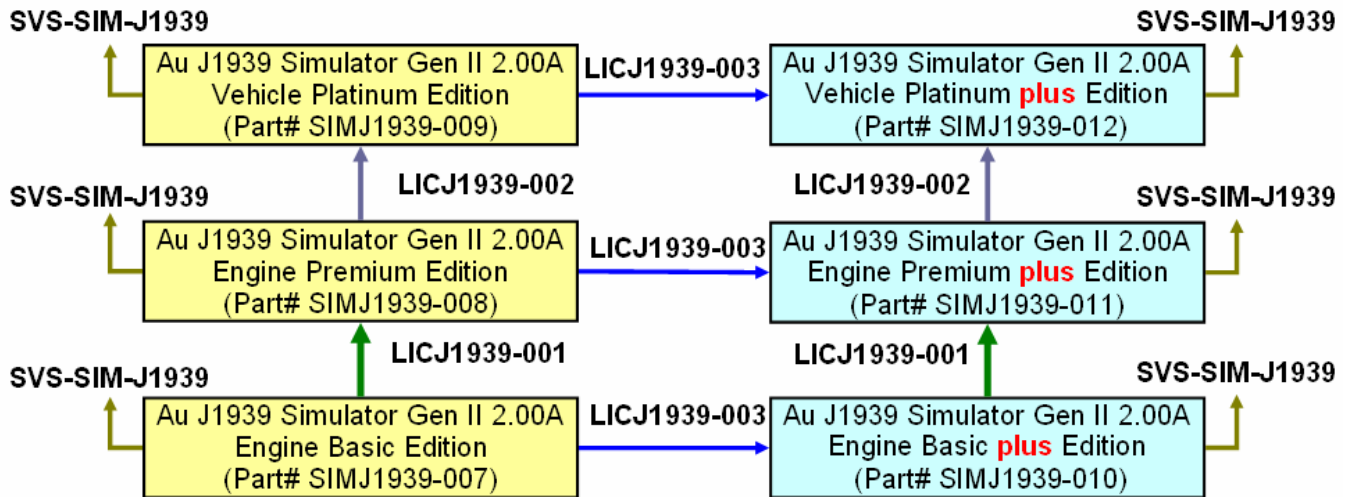

Figure 1-5 License upgrade and service for Au J1939 Simulators (Gen II) 2.00A

- Simulator license can be in-field upgraded to higher editions with a license management toolset: e.g. upgrade an Au J1939 Simulator from Engine Basic Edition to Engine Premium Edition (LICJ1939-001) or from premium edition to platinum edition (LICJ1939-002). "Non-Plus" edition is also able to be upgraded to plus editions (LICJ1939-003).
- Software code (firmware) can be in-field updated with Au PIC Bootloader, for instance, updated firmware code or custom-made codes can be re-programmed to gain new or special features.
- One year support and minor upgrade service is available (SVS-SIM-J1939).



Chapter 2 Supported SAE J1939 Parameters

2.1. Engine Basic Edition(S)

Au SAE J1939 Simulator Gen II 2.00A Engine Basic Edition(s) support the majority of SAE J1939 engine parameters:

- Engine Speed (RPM) (SPN190)
- Wheel-Based Vehicle Speed (MPH) (SPN 84)
- Engine Oil Pressure(PSI) (SPN 100)
- Engine Coolant Temperature(F) (SPN 110)
- Battery Potential (Voltage), Switched (SPN 158)
- Fuel Level (%) (SPN 96)
- Engine Turbocharger Boost Pressure (PSI) (SPN 102)
- Engine Instant Fuel Economy (SPN 184)
- Engine Fuel Rate (SPN 183)
- Accelerator Pedal Position 1 (SPN 91)
- Engine Intake Manifold 1 Temperature (F) (SPN 105)
- Engine % Load at Current Speed (SPN 92)
- Engine Trip Distance (SPN 244)
- Total Vehicle Distance (SPN 245)
- Engine Total Hours of Operation (Hr) (SPN 247)
- Response for Engine Hour Request
- Engine Clock (HH:MM) (SPN 961, 960)
- Response for Engine Clock Request
- Engine Clock setup (SPN 1605, 1604)
- Cruise Light (SPN 595)
- SAE J1939 Acknowledge protocol (ACK, NACK)
- Engine Address Claimed
- Engine Address CANNOT Claim
- Response for Address Claim Request
- Address Conflict Response with Contention
- Engine DM1 Red Stop Lamp OFF status (SPN 623)
- Engine DM1 Amber Lamp OFF status (SPN 624)
- Engine DM1 (Health-heart-beat) *
- Water-in-Fuel (WIF) Indicator (Health-heart-beat)* (SPN 97)
- **Engine Oil Temperature 1 (SPN 175)**
- **Engine Fuel Temperature (F) (SPN 174)**
- **Engine Oil Level (%) (SPN 98)**
- **Engine Coolant Pressure (PSI) (SPN 109)**
- **Engine Coolant Level (%) (SPN 111)**
- **Engine IS (Idle Shutdown) has Shutdown Engine (SPN 593)**
- **Engine IS Driver Alert Mode (SPN 594)**
- **Engine IS Timer Override (SPN 592)**
- **Engine IS Timer State (SPN 590)**
- **Engine IS Timer Function (SPN 591)**
- **A/C High Pressure Fan Switch (SPN 985)**
- **Refrigerant Low Pressure Switch (SPN 875)**
- **Refrigerant High Pressure Switch (SPN 605)**
- **Engine Wait to Start Lamp (SPN 1081)**
- **EPS (Engine Protection System)has Shutdown Engine (SPN 1110)**
- **EPS Approaching shutdown (SPN 1109)**
- **EPS Timer Override (SPN 1108)**
- **EPS Timer State (SPN1107)**
- **EPS Configuration (SPN 1111)**
- **Engine Alarm Acknowledge (SPN 2815)**



- Engine Alarm Output Command Status (SPN 2814)
- Engine Air Shutoff Command Status (SPN 2813)
- Engine Overspeed Test (SPN 2812)
- Engine Air Inlet Pressure (SPN 106)
- Engine Exhaust Gas Temperature (SPN 173)
- Actual Engine - Percent Torque (SPN 513)
- Nominal Friction - Percent Torque (SPN 514)
- Engine Exhaust Gas Recirculation (EGR) Mass Flow Rate (MFR) (SPN 2659)
- Engine Inlet Air Mass Flow Rate (MFR) (SPN 132)
- Vehicle Identification Number (VIN) (SPN 237)
- Response for VIN global request
- Response for VIN specific request
- SAE-J1939 Transport Protocol: TP.CM.BAM, TP.DT
- SAE-J1939 Transport Protocol: TP.CM.RTS, TP.CM.CTS, TP.DT, TP.CM.EndOfMsgACK, TP.Conn.Abort

* Health-heart-beat: normal signal only, no warning. Signal repeats at SAE defined “heart-beat” rate.

2.2. Engine Premium Edition(S)

Au SAE J1939 Simulator Engine Premium Edition(s) support all the SAE J1939 parameters listed with Engine Basic Edition(s), plus the following SAE J1939 parameters and new features:

- Engine DM1 Warning On/Off control
- Engine DM2 On/Reset control
- Engine Red Stop Lamp On/Off
- Engine Amber Lamp On/Off
- Water In Fuel Indicator On/Off
- Engine DM1 Single-Packet warning
- Engine DM1 Multi-Packet warnings
- SAE J1939 TP.CM.EndOfMsgAck, TP.CM.RTS, TP.CM.CTS, TP.Conn.Abort, TP.DT protocol
- Engine DM2 Single-Packet warning
- Engine DM2 Multi-Packet warnings
- Response for DM2 global request
- Response for DM2 specific request
- Engine DM3 and Engine DM2 On/Reset control
- SAE J1939 TP.CM.BAM, TP.DT protocol

2.3. Vehicle Platinum Edition(S)

Au SAE J1939 Simulator vehicle Platinum Edition(s) support all SAE J1939 parameters listed with Engine Premium Edition(s), and the following SAE J1939 parameters and new features:

- Engine Configuration
- ABS address claimed
- ABS Address CANNOT Claim
- ABS Response Request for Address Claim
- ABS Address Conflict Response with Contention
- ABS Red Stop Lamp On/Off
- ABS Amber Lamp On/Off
- ABS DM1 (No warning or 1 warning)
- ABS Heart-beat PGN-EBC1
- Transmission Address Conflict Response with Contention
- Transmission address claimed
- Transmission Address CANNOT Claim
- Transmission Response Request for Address Claim
- Transmission Red Stop Lamp On/Off
- Transmission Amber Lamp On/Off
- Transmission DM1 (No warning or 1 warning)
- Transmission Oil Temperature
- Transmission Heart-beat PGN-ETC

Chapter 3 Operating Instructions

All editions of Au SAE J1939 Simulator (Gen II) can be operated by just controlling 3 push buttons. It generates SAE J1939 signals for product developers, testers, operators and manufacturers.

3.1. Power On

Plug in a 4-wire cable (e.g. Au Part#: CBL-CAN-01) to the Au SAE J1939 Simulator (Gen II) DB9 male connector (on **BUS** side). When the CBL-CAN-01 cable is used, connect the **Red** wire to +12 ~ +24V DC power supply, **Black** wire to ground, **White** wire to CAN-H, **Green** wire to CAN-L. The **Power** LED on simulator will light up, and simulator will resume the last saved operating mode (static mode or dynamic mode).

Note: the 4-wire cable (CBL-CAN-01) is color coded as shown in Table 1-2 (Chapter 1) and is ordered separately.

3.2. Operating Modes (Static/Dynamic)

After power on, Au SAE J1939 Simulator will work in either **static** mode or **dynamic** mode.

- **Static mode:** Au SAE J1939 Simulator (Gen II) generates steady SAE J1939 signals. In this mode, two push buttons (**Up** and **Down**) can be used to change the data outputs. When no button is pushed, all data will stay at the last value.
- **Dynamic mode:** The value of all data will change automatically in SAE J1939 defined range.
- Switch between dynamic mode and static mode: press and hold both **Menu** and **Up** buttons until a long beep is heard if buzzer is enabled; or both the "▼0% LED" and the "▲100% LED" flip their status (from on to off or vice versa)

There are 3 push buttons (**Menu**, **Down**, **Up**) and 9 LEDs (Figure 3-1). Each LED is named after its function.

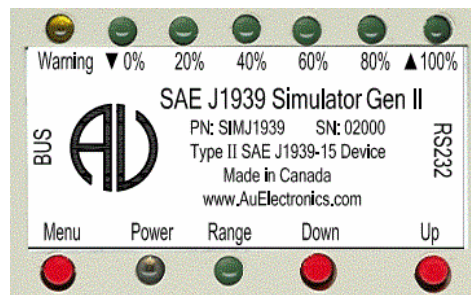

Figure 3-1 Position of push buttons and LEDs

3.3. Push Button Functions

The push button functions are summarized in Table 3-1.

Table 3-1 Summary of push button functions

Push Button Operation	Function
Press Down button	Decrease all simulated data until they reach the lowest value
Press Up button	Increase all simulated data until they reach the highest value
Press Menu button	DM1 Warning On/Off control (N.A. for Engine Basic Edition(s))
Press & hold Menu button when power on	Simulator will enter Bootloader mode, if no communication is detected from a PC Bootloader program within 10 seconds, it'll resume normal modes
Press & hold both Down + Up button	Buzzer ON/OFF control
Press & hold both Menu + Up button	Switch between Static/Dynamic mode
Press & hold both Menu + Down button	Engine DM2 ON/Reset control (N.A. in Engine Basic Edition)

- Press **Menu** button:
 - Menu button is used to control Warning LED on/off. A single press on Menu button will turn on the Warning LED if the Warning LED was off, and vice versa.
 - The Menu button function is available only on Engine Premium Edition(s) and Vehicle Platinum Edition(s). In Engine Basic Edition(s), Menu button is not used, Warning LED is constantly off.
 - If buzzer is enabled, a short beep will be heard upon a press on the Menu button.



In dynamic mode, the simulator automatically adjusts the control step value by itself. This will generate dynamic J1939 signals. In static mode, all* simulated SAE J1939 signal will be controlled by the control step value, which is still able to be manually controlled by the **Up** and **Down** buttons.

Note: * The Engine Clock is not controlled by the control step value and push buttons; it runs all by itself just like a real clock.

- Press **Down** button:
 - **Down** button is used to decrease the values of all J1939 signals. A single press will decrease all data one step from previous values until they reach the minimum values. ▼0% LED will be triggered on or off.
 - If ▼0% LED is on, press **Down** button one time, ▼0% LED will be off.
 - If ▼0% LED is off, press **Down** button one time, ▼0% LED will be on.
 - 80% LED blinks when control step value equals to 80%,
 - 60% LED blinks when control step value equals to 60%,
 - 40% LED blinks when control step value equals to 40%,
 - 20% LED blinks when control step value equals to 20%,
 - ▼0% LED blinks when control step equals to 0%,
 - If buzzer is enabled, a short beep will be heard upon a press on Down button.
- Press **Up** button:
 - **Up** button is used to increase the values of all J1939 signals. A single press will increase all simulated data one step to next data level until they reach the maximum values, ▲100% LED will be triggered on or off.
 - If ▲100% LED is on, press **Up** button one time, ▲100% LED will be off.
 - If ▲100% LED is off, press **Up** button one time, ▲100% LED will be on.
 - 20% LED blinks when control step value equals to 20%,
 - 40% LED blinks when control step value equals to 40%,
 - 60% LED blinks when control step value equals to 60%,
 - 80% LED blinks when control step value equals to 80%,
 - ▲100% LED blinks when control step value equals to the highest value, 100%.
 - If buzzer is enabled, a short beep will be heard upon a press on Up button.
- Press and hold both **Down + Up** button for more than 1 second:
 - Down + Up buttons are used to turn buzzer on/off.
 - If buzzer is on, press and hold **Down + Up** for more than 1 second will silent buzzer thereafter.
 - If buzzer is mute, press and hold **Down + Up** for more than 1 second will enable the buzzer thereafter.
 - Both ▲100% and ▼0% LED will flip their on/off status as a visual indication of this dual-button input.
 - If buzzer is enabled, a long beep will be heard to reflect the input of **Down + Up** button.
- Press and hold both **Menu + Down** button for more than 1 second:
 - **Menu + Down** buttons are used to turn Engine DM2 warning on/Reset.
 - Both ▲100% LED and ▼0% LED will flip their status as a visual indication of this dual-button input.
 - If buzzer is enabled, a long beep will be heard to reflect the input of **Menu + Down** button.
 - The Engine DM2 warning messages (available only at premium editions and platinum editions) are always on after power-on. It can be reset when an Engine DM3 PGN is received.
 - For continuous test purpose, after an Engine DM3 PGN is received, either re-power-on the simulator or press and hold both **Menu + Down** button for more than 1 second will turn on the Engine DM2 warning again.
- Press and hold both **Menu + Up** button for more than 1 second:
 - **Menu + Up** buttons are used to switch between static and dynamic mode.
 - Both ▲100% LED and ▼0% LED will flip their status as a visual indication of this dual-button input.
 - If buzzer is enabled, a long beep will be heard to reflect the input of **Menu + Up** button.

3.4. LED Indicator Status

Note: Red LEDs and Green LEDs are used in this document for illustration purpose; actual product might have different LED colors. Same applies to the push buttons. Au Group Electronics reserve the right of changing the color on each LEDs and push buttons without further notification.

- When power on, both **Power** LED and **Range** LED lit, as shown in Figure 3-2.

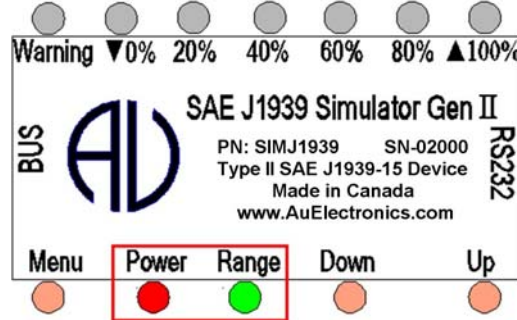

Figure 3-2 Power on, both Power and Range LED lit

All SAE J1939 data can be changed within the SAE defined range from 0 to 100 control steps (named 0% to 100% control step value from now on), 6 LEDs are used to identify the control step value in the range of 0%, 20%, 40%, 60%, 80%, and 100%.

- **▲100%** LED will be triggered on or off with a press on the **Up** button, accompany with the increasing brightness of **Range** LED. A press on the **Up** button will also increase the control step value and all simulated data.
 - When control step value equals to 0%, the **▼0%** LED blinks.
 - When control step value equals to 20%, 20% LED blinks.
 - If keep pressing **Up** button, the control step value will keep increasing. The 20% LED will then be always on, as shown in Figure 3-3. This indicates a data range from 21- 39%.

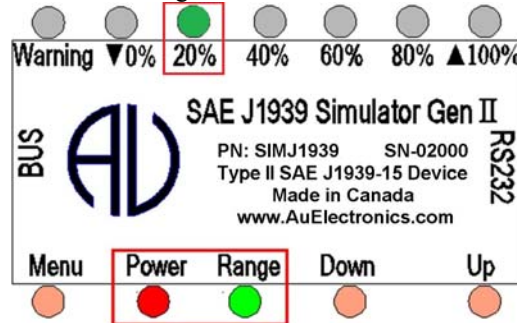

Figure 3-3 Power, Range, 20% LED on, indicating data range is from 21% to 39%

- When control step value equals to 40%, 40% LED blinks.
- If keep pressing **Up** button, the control step value will keep increasing. The 20% and 40% LED will be always on, as shown in Figure 3-4. It indicates the data range from 41% to 59%.

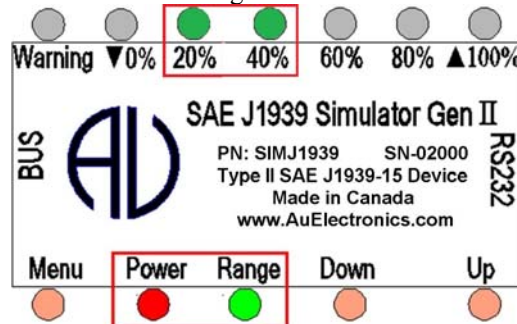

Figure 3-4 Power, Range, 20%, 40% LED on, indicating data range is from 41% to 59%

- When control step value equals to 60%, 60% LED blinks
- If keep pressing **Up** button, the control step value will keep increasing. The 20%, 40%, and 60% LED will be on, as shown in Figure 3-5. It indicates the data range from 61% to 79%.

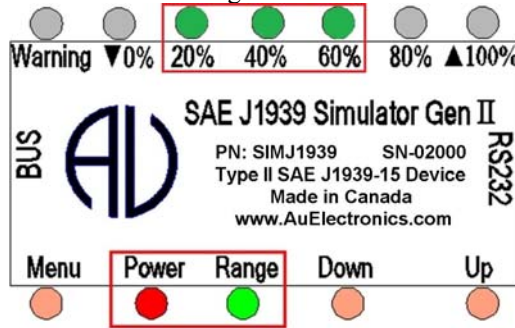

Figure 3-5 Power, Range, 20%, 40%, 60% LED on, indicating data range is from 61% to 79%

- When control step value equals to 80%, 80% LED blinks.
- If keep pressing **Up** button, the control step value will keep increasing. The 20%, 40%, 60%, and 80% LED will be on, as shown in Figure 3-6. It indicates the data range from 81% to 99%.

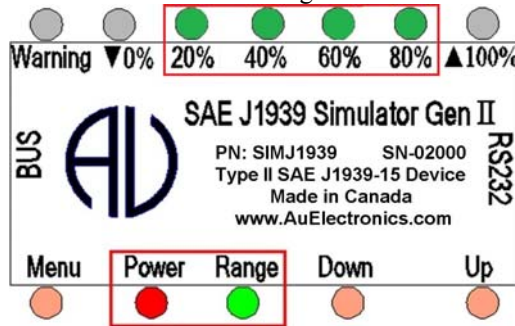

Figure 3-6 Power, Range, 20%, 40%, 60%, 80% LED on, indicating data range is from 81% to 99%

- When control step value equals to 100%, the 20%, 40%, 60%, and 80% LED will be constant on. ▲100% LED blinks, as shown in Figure 3-7.

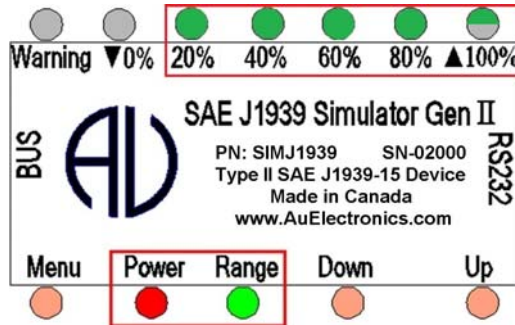

Figure 3-7 Power, Range, 20%, 40%, 60%, 80% are constant on, “▲100%” LED blinks, indicating data reaches 100%

- ▼0% LED will be triggered on or off when pressing **Down** button, accompany with the decreasing brightness of Range LED. A press on the **Down** button will also decrease the control step value and all simulated data. When the control step value equals to 0%, ▼0% LED blinks.

The control step value vs. LED indicator status is summarized in Table 3-2.



Table 3-2 Control step value vs. LED indicator status (in Static Mode)

Step	Operation	LED Status
1	Connect +12~+24 V DC power supply	Power, Range LED on, the rest LED will recall the last saved status at Static mode
2	Press Down button	▼ 0% LED on/off
3	Continue press Down button until control step value = 0%	▼ 0% LED blink
4	Press Up button	▲ 100% LED on/off
5	Continue press Up button for control step value 1 to 19%	Power, Range LED constant on
6	Continue press Up button for control step value 20%	Power, Range LED on, 20% LED Blink
7	Continue press Up button for control step value 21 to 39%	Power, Range LED on, 20% LED on
8	Continue press Up button for control step value 40%	Power, Range, 20% LED ON, 40% LED Blink
9	Continue press Up button for control step value 41 to 59%	Power, Range, 20%, 40% LED on
10	Continue press Up button for control step value 60%	Power, Range, 20%, 40% LED on, 60% LED blink
11	Continue press Up button for control step value 61 to 79%	Power, Range, 20%, 40%, 60% LED on
12	Continue press Up button for control step value 80%	Power, Range, 20%,40%, 60% LED on, 80% LED blink
13	Continue press Up button for control step value 81 to 99%	Power, Range, 20%, 40%, 60%, 80% LED on
14	Continue press Up button for control step value 100%	Power, Range, 20%, 40%, 60%, 80% LED on, ▲ 100% blink

Chapter 4 Au J1939 Simulator Remote Terminal

For all Au SAE J1939 Simulator Gen II 2.00A "Plus" editions, the "Au J1939 Simulator Remote Terminal Ver. 2.00A" software can be used to control and display simulated SAE J1939 signals from a personal computer.

The Remote Terminal Ver 2.00A software requires a minimum simulator firmware version of 0.2A or higher. Otherwise, it will not function and a warning message will pop up, as shown in Figure 4-1.

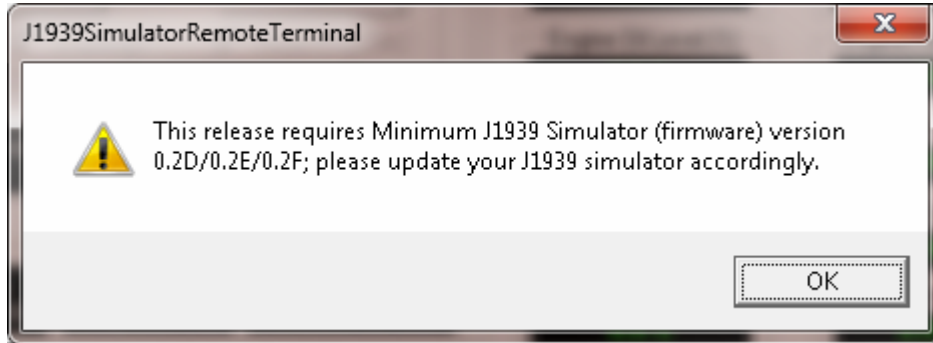

Figure 4-1 Warning message about minimum firmware requirement

The Remote Terminal GUI (Graphic User Interface) includes a control panel and a display panel. Control panel is located in the up-left corner. All the other area is used for displaying information like engine/ABS/Transmission info, warning lamp, etc. as shown in Figure 4-2, 4-3, 4-4.

Figure 4 -2 shows the J1939 Simulator Remote Terminal GUI for Au SAE J1939 Simulator (Gen II) 2.00A vehicle platinum plus edition. All features are active.

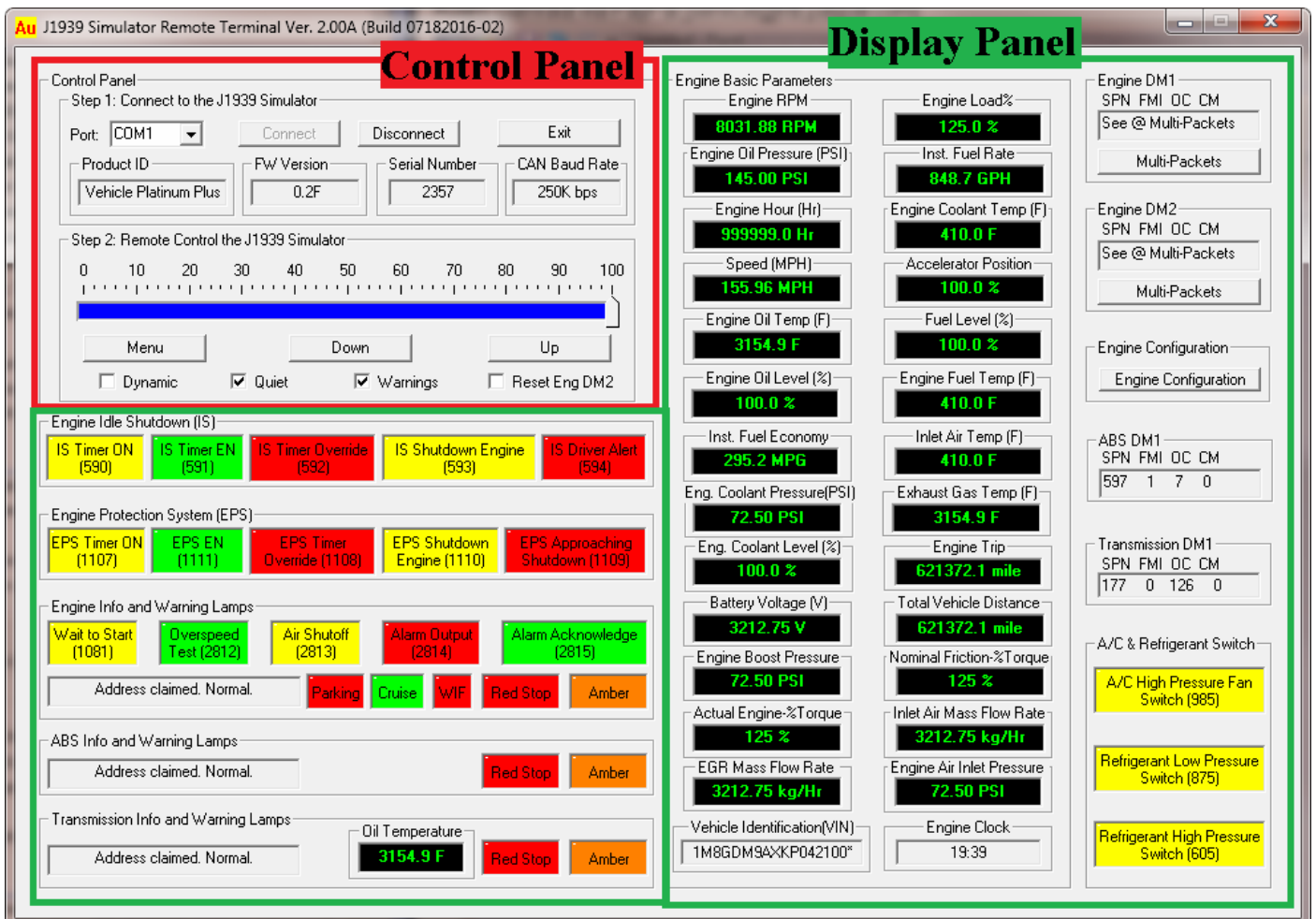

Figure 4-2 PC Remote Terminal-Gen II 2.00A Vehicle Platinum Plus Edition

Au J1939 Simulator Remote Terminal Structure is summarized in Figure 4-3:

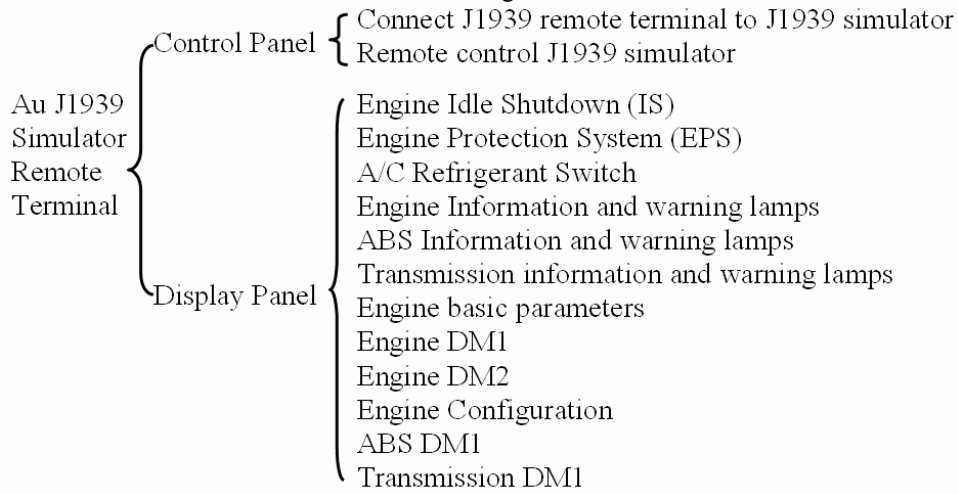

Figure 4-3 Au J1939 Simulator Remote Terminal Structure

Figure 4-4 shows the J1939 Simulator Remote Terminal GUI for *Engine Premium Plus* edition. Engine Idle Shutdown (IS), Engine Protection System (EPS), Engine Info and Warning lamps, Engine Basic Parameters, A/C & Refrigerant Switch, Engine DM1, and Engine DM2 are included.

ABS info and Warning Lamps, Transmission info and Warning Lamps, Engine Configuration, ABS DM1, and Transmission DM1 are **not** available.

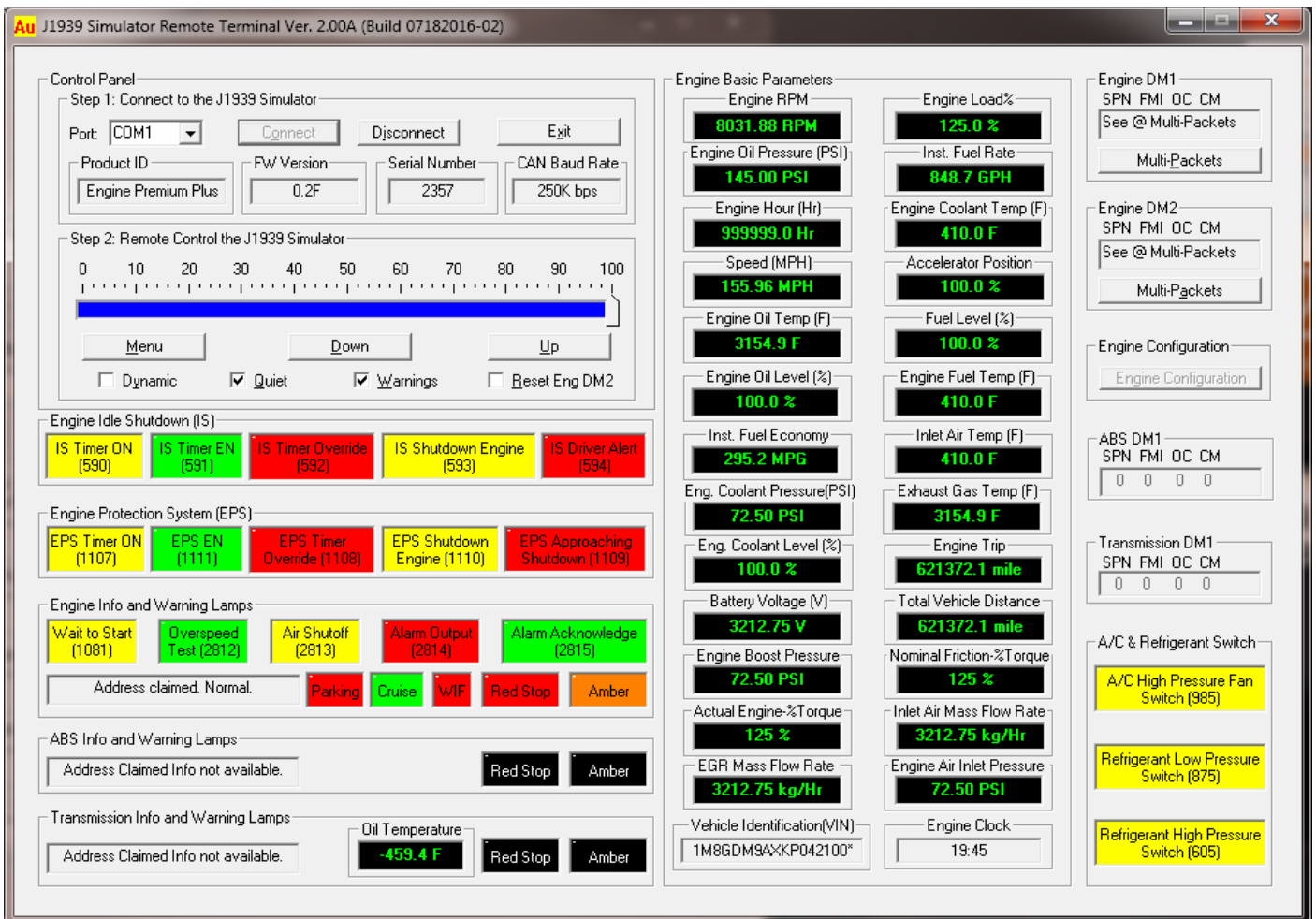

Figure 4-4 Au J1939 Simulator Remote Terminal GUI – Engine Premium Plus

Figure 4-5 shows the J1939 Simulator Remote Terminal for *Engine Basic Plus* edition. Engine Idle Shutdown (IS), Engine Protection System (EPS), A/C & Refrigerant Switch, Engine Info, Cruise lamps, and Engine Basic Parameters are active. ABS info and Warning Lamps, Transmission Info and Warning Lamps, Engine DM1, Engine DM2, Engine Configuration, ABS DM1, Transmission DM1 are **not** available.

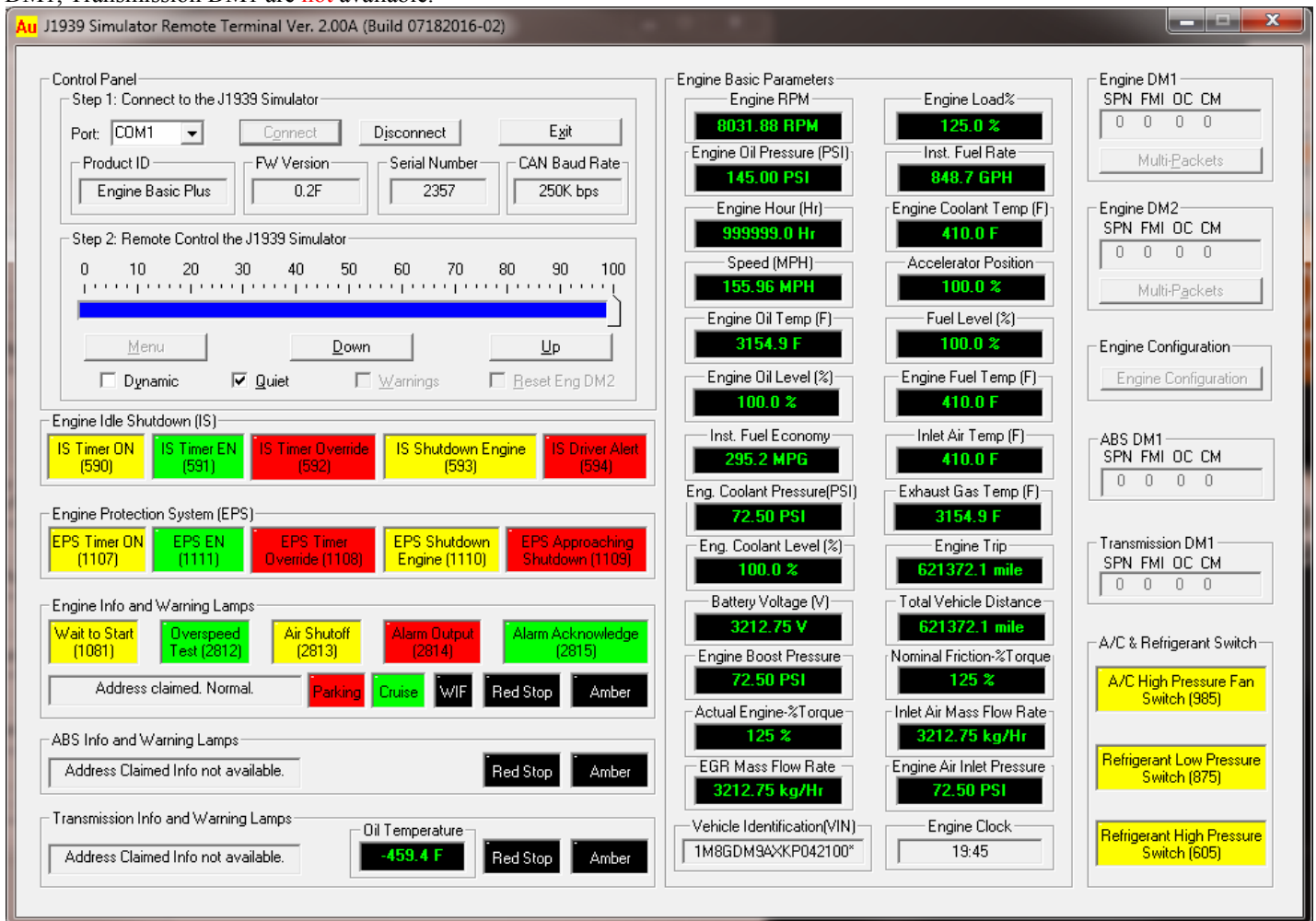

Figure 4-5 Au J1939 Simulator Remote Terminal GUI – Engine Basic Plus

Following paragraphs will explain how to use the GUI remote-control of the J1939 Simulator Gen II 2.00A **Plus** editions.

4.1.Step 1: Connect To J1939 Simulator

Connect the simulator to power supply and a CAN network, and then connect it to a PC serial port. Select serial port from the "Port" drop down list → click "Connect" button → Product information of the connected J1939 simulator device will display (Product ID, Simulator Version (firmware), and serial number), as shown in Figure 4-6.

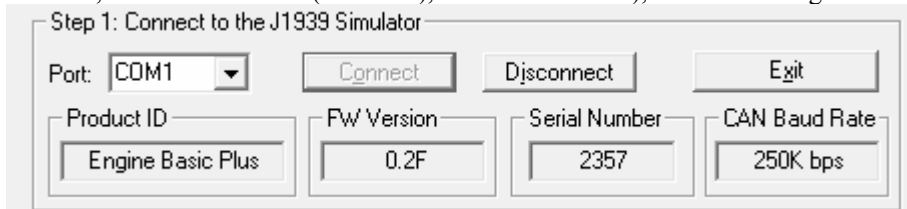

Figure 4-6 J1939 simulator remote terminal control panel step

Note: The control panel step 1 can always be used to display Product ID, FW Version, Serial Number, and CAN Baud Rate for all Au J1939 simulator Editions (both **plus** edition and **non-plus** edition).

The function of step 1 control items is summarized in Table 4-1.

Table 4-1 Function summary of step 1 control items

Items	Function
Port	Serial port can be selected from drop down list (COM1 to COM9)
Connect	Click “Connect” button to connect J1939 simulator with selected PC serial port.
Disconnect	Click “Disconnect” button to release the selected PC serial port.
Exit	Click “Exit” button to close the J1939 remote terminal program
Product ID	Display the current edition of J1939 simulator that’s hooked up with the serial port. (e.g. The demonstration in Figure 4-2 is a Vehicle Platinum Plus Edition)
FW Version	Display the current firmware version of J1939 simulator that’s hooked up with the serial port. (The demonstrated version of the connected simulator in Figure 4-2 is 0.2A)
Serial Number	Display the serial number of J1939 simulator that’s connected to the serial port. (The demonstrated serial number for the connected simulator in Figure 4-2 is 205)
CAN Baud Rate	CAN Baud Rate of J1939 simulator, can be configured to : 62.5K, 125K, 250K, 500K, 1M bps Please refer to the appendix B for detail information on how to configure CAN Baud Rate.

4.2.Step 2: Remote Control the J1939 Simulator

Remote control includes a scale bar, 3 push buttons (**Menu**, **Down**, **Up**), and 4 check boxes (Dynamic, Quiet, Warnings, Reset Eng DM2) as shown in Figure 4-7. These tools are able to remote control the output/simulated signal of the Au J1939 Simulator **PLUS** editions.

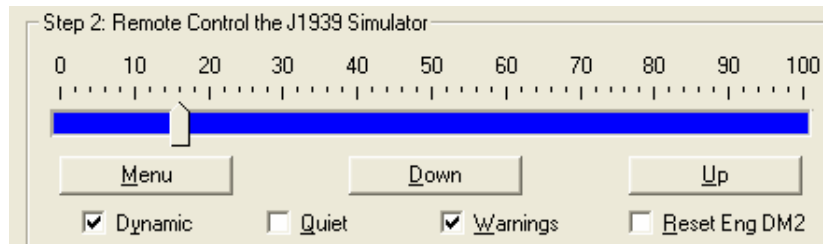

Figure 4-7 PC remote terminal control panel step 2

The scale bar represents the control step values from 0% to 100%. The sliding action can be made by 3 methods: keyboard, mouse or Down/Up buttons from remote terminal. They are summarized in Table 4-2

Table 4-2 Control methods for scale bar

	Action	Function
Mouse	Left click	Left click bring the slide to the desire location.
	Drag	Click and hold left button drag the slide to desire location
Keyboard	▲ or ►	Increase the scale range in 1 interval
	▼ or ◀	Decrease the scale range in 1 interval
	Pg Up	Increase the scale range in 10 interval
	Pg Dn	Decrease the scale range in 10 interval
Remote terminal	“Down” button	Decrease the scale range in 1 interval
	“Up” button	Increase the scale range in 1 interval

The functions for the 3 push buttons and 4 check boxes are listed in Table 4-3.

Table 4-3 Functions for push button and check boxes in step 2

Tool	Function	
Button	Menu*	Turn on/off warning (see note below)
	Down	Decrease the control step value in 1
	Up	Increase the control step value in 1
Check box	Dynamic	Switch between dynamic mode / static mode
	Quiet	Turn on/off buzzer
	Warning	Turn on/off Eng/ABS/Trans DM1 warnings & WIF indicator
	Reset Eng DM2	Turn on/reset all Engine DM2 code

*Note: Menu button is active only in the **Engine Premium Plus** edition and **Vehicle Platinum Plus** edition.

4.3. Display Panel – Engine Idle Shutdown (IS)

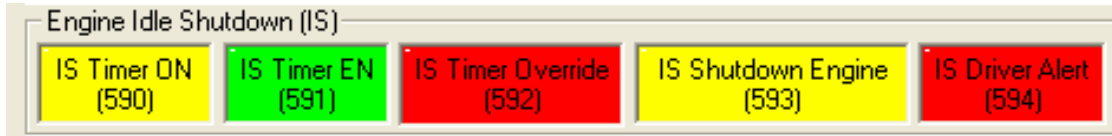

Figure 4-8 Engine Idle Shutdown Display Panel

"Engine Idle Shutdown (IS)" displays the control status of Engine Idle Shutdown. Here is a summary of each control status (for more info, please refer to SAE J1939-71 and Table 5-2 in Chapter 5):

IS Timer EN (591): It is also named "Engine Idle Shutdown Timer Function", which indicates the configuration (disabled or enabled in calibration) of the idle shutdown timer system.

IS Timer ON (590): It is also named "Engine Idle Shutdown Timer State", which indicates the current operation mode (active or inactive) of the idle shutdown timer system.

IS Driver Alert (594): It is also named "Engine Idle Shutdown Driver Alert Mode", which indicates the status (active or inactive) of the driver alert mode of the idle shutdown timer system. While the driver alert mode is active, the idle shutdown timer may be overridden.

IS Timer Override (592): It is also named "Engine Idle Shutdown Timer Override", which indicates the status (active or inactive) of the override feature of the idle shutdown timer system.

IS Shutdown Engine (593): It is also named "Engine Idle Shutdown has Shutdown Engine", which identifies whether or not the engine has been shutdown by the idle shutdown timer system.

4.4. Display Panel – Engine Protection System (EPS)

"Engine Protection System (EPS)" displays the control status of Engine Protection System. Here is a summary of each control status (for more info, please refer to SAE J1939-71 and Table 5-3 in Chapter 5):



Figure 4-9 Engine Protection System Display Panel

EPS EN (1111): It is also named "Engine Protection System Configuration", which indicates the configuration (disabled or enabled in calibration) of the engine shutdown system.

EPS ON (1107): It is also named "Engine Protection System Timer State", which indicates the current mode (active or inactive) of the engine protection system timer system.

EPS Approaching Shutdown (1109): It is also named "Engine Protection System Approaching Shutdown", which indicates whether engine shutdown is imminent (approaching or not approaching).

EPS Timer Override (1108): It is also named "Engine Protection System Timer Override", which indicates the status (active or inactive) of the override feature of the engine protection system timer.

EPS Shutdown Engine (1110): It is also named "Engine Protection System has Shutdown Engine", which indicates whether or not the engine protection system has shutdown the engine.

4.5. Display Panel – A/C & Refrigerant Switch

A/C High Pressure Fan Switch (985): the "ON" status indicates that the pressure in the coolant circuit of an air conditioning system is high and the fan may be engaged.

Refrigerant Low Pressure Switch (875): indicates the position of the low pressure switch in the coolant circuit of an air conditioning system. When the switch is enabled, the pressure inside the circuit is too low and the compressor clutch may be disengaged.

Refrigerant High Pressure Switch (605): indicates the position of the high pressure switch in the coolant circuits of an air conditioning system. When the switch is enabled, the pressure inside the circuit is too high and the compressor clutch may be disengaged.

For more information, please refer to SAE J1939-71 and Table 5-6 in Chapter 5

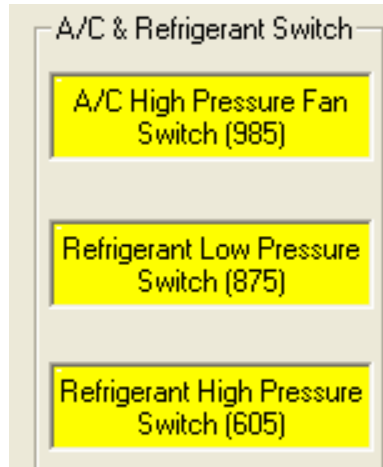

Figure 4-10 A/C & Refrigerant Switch

4.6. Display Panel – Engine Info and Warning Lamps

It displays the following parameters: the engine address claim information, information lamps (Cruise lamp, water in fuel (WIF) indicator, Wait to Start, Overspeed Test, Air Shutoff, Alarm Output, and Alarm Acknowledge), and 2 engine DM1 warning lamps (Red Stop, Amber), as shown in Figure 4-11. The lamp ON status is listed in Table 5-5 (Chapter 5).



Figure 4-11 Display Engine info and warning lamps

Wait to Start Lamp (1081): indicates that the engine is too cold to start and the operator should wait until the signal becomes inactive (turns off).

Overspeed Test (2812): The engine overspeed test signal as measured by the reporting ECM. Engine Overspeed Test is a mechanism to simulate engine overspeed situations, while operating the engine within the engine's safe operating range. It indicates a condition when the over-speed test input to the ECM is being driven.

Air Shutoff (2813): it indicates when the Air Shutoff driver output is being driven. When it is off, it means the controller wants air flow to the engine and it is not attempting to shutoff engine air supply. When it is on, it means the controller is attempting to shutoff engine air supply.

Alarm Output (2814): it indicates when the alarm driver output is being driven. Not active means the controller has no alarm level conditions.

Alarm Acknowledge (2815): It is a mechanism for external acknowledgement of SPN 2814.

4.7. Display Panel – Abs Info and Warning Lamps



Figure 4-12 Display ABS info and warning lamps

It displays the ABS address claiming information and 2 warning lamps for ABS (Red Stop, Amber), as shown in Figure 4-12.

4.8. Display Panel – Transmission Info and Warning Lamps

It displays the transmission address claiming information, transmission oil temperature, and 2 warning lamps for transmission (Red Stop, Amber), as shown in Figure 4-13.



Figure 4-13 Display transmission info and warning lamps

4.9. Display Panel – Engine Basic Parameters

Display the following 28 engine basic parameters:

- Engine RPM,
- Engine hour (Hr),
- Vehicle speed (MPH),
- Engine oil pressure (PSI),
- Engine Oil Temperature (F),
- Engine Oil Level (%),
- Engine coolant temperature (F),
- Engine Coolant Pressure (PSI),
- Engine Coolant Level (%),
- Battery voltage (V),
- Engine boost pressure (PSI),
- Actual Engine-% Torque,
- EGR Mass Flow Rate,
- Vehicle Identification,
- Accelerator Position,
- Engine Load %,
- Instant fuel economy (MPG),
- Instant fuel rate (GPH),
- Fuel Level %,
- Engine Fuel Temp (F),
- Inlet Air Temp (F),
- Exhaust Gas Temp (F),
- Engine Trip, Total Vehicle Distance (mile),
- Nominal Friction-% Torque, Inlet Air Mass Flow Rate,
- Engine Air Inlet Pressure,
- Engine Clock * (HH:MM)

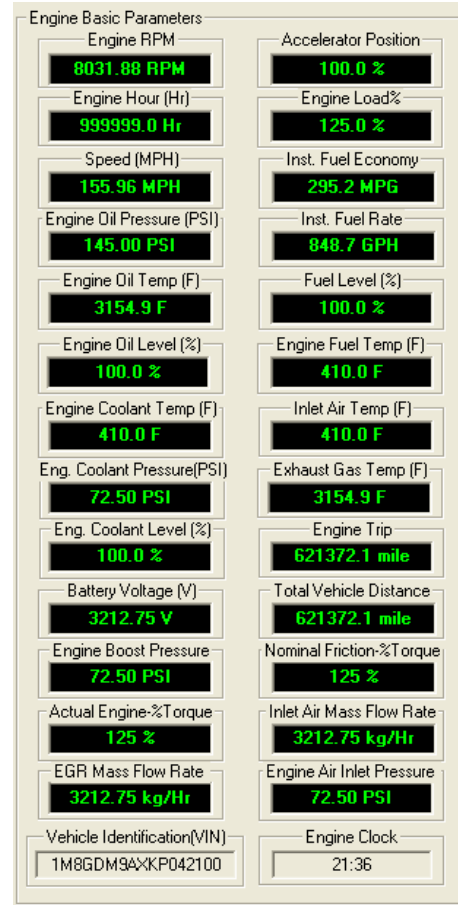

Figure 4-14 Display panel – Engine basic parameters

***Note:** Engine Clock is not controlled by the control step value. It runs by itself like a real clock, and can be setup by PGN 54528.

4.10. Display Panel – Engine DM1

Engine DM1 message could be one packet (without warning or with 1 warning) or multi-packets.

- When engine DM1 is a single packet message, SPN, FMI, OC, CM will display (Figure 4-15).
- When engine DM1 is a multi-packet message, the "see @ Multi-Packets" info will display, and the "Multi-packets" button will be active (Figure 4-16). Click the button, the whole list of engine DM1 will display (Figure 4-17).

If Engine DM1 warning is off, a SAE defined non-warning message will be shown as (0,0,0,0).

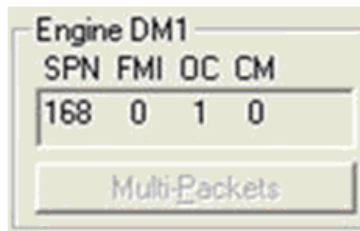

Figure 4-15 Engine DM1 single packet showing SPN, FMI, OC, CM. "Multi-Packets" button is non-active

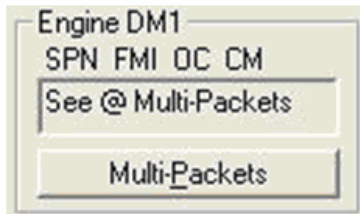
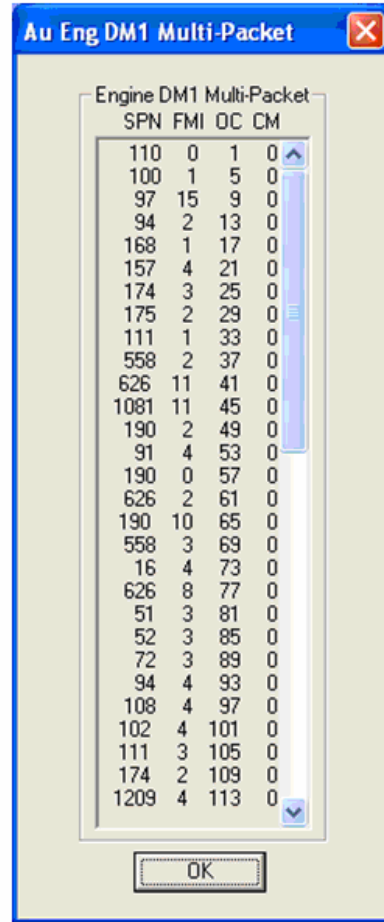

Figure 4-16 Engine DM1 Multi-packets showing "See @ multi-Packets", and "Multi-Packets" button is active

Figure 4-17 Click on "Multi-Packets" button, the whole list of engine DM1 code display



4.11. Display Panel – Engine DM2

Engine DM2 message could be one packet or multi-packets.

If engine DM2 is a single packet, SPN, FMI, OC, CM will display (Figure 4-18).

If engine DM2 is in multi-packets format, "see @ Multi-Packets" will display, "Multi-packets" button will be active (Figure 4-19). Click on the button, the whole list of engine DM2 will display (Figure 4-20).

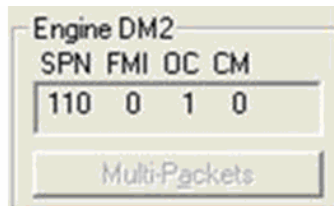

Figure 4-18 engine DM2 is a single packet, showing SPN, FMI, OC, CM, "Multi-Packets" button is non-active

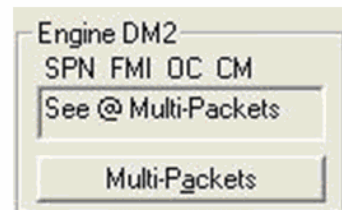

Figure 4-19 engine DM2 multi-packets, showing "See@Multi-Packets", "Multi-Packets" button is active

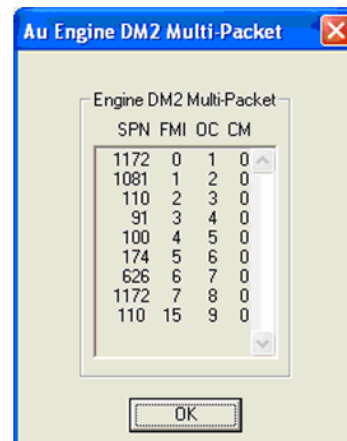

Figure 4-20 Click on "Multi-packets" button, the whole list of engine DM2 code display

Note 1: The "Multi-Packets" buttons are used as a trigger for a pop-up sub-window which will display all DM1/DM2 code. It is not used to turn on/off Multi-Packets DM1/DM2.

Engine DM1 Multi-Packets button will be available when both of the following two conditions are met (Figure 4-21):

- **Warning is on**
- **Control step value is 100**

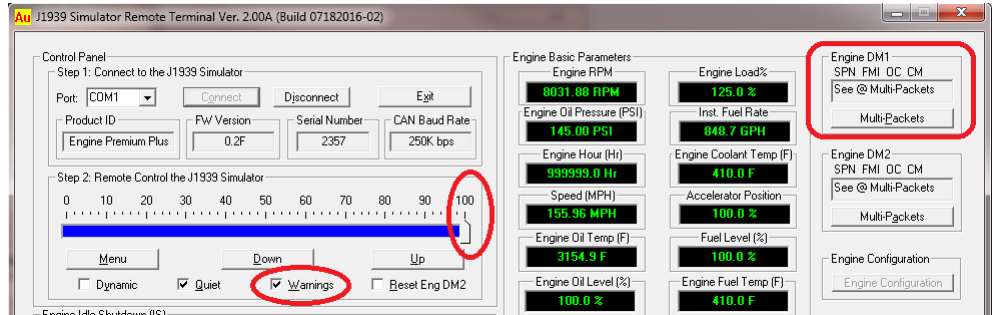

Figure 4-21 Activate Multi-Packets of Engine DM1

Engine DM2 Multi-Packets button will be available when:

- **Control step value is 100**

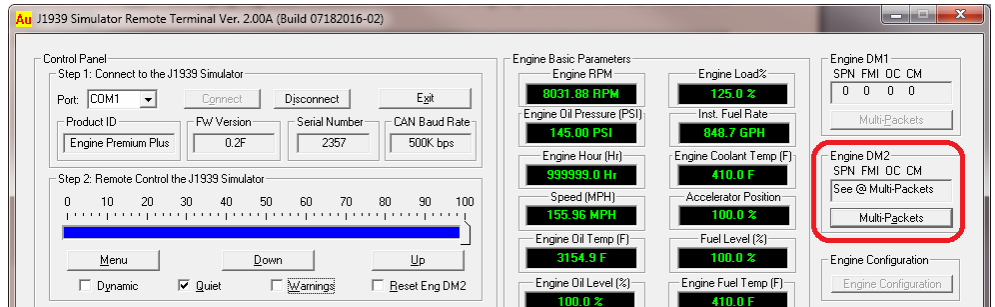

Figure 4-22 Activate Multi-Packets of Engine DM2

Engine DM2 will be reset to 0 when:

- **"Reset Eng DM2" is checked**

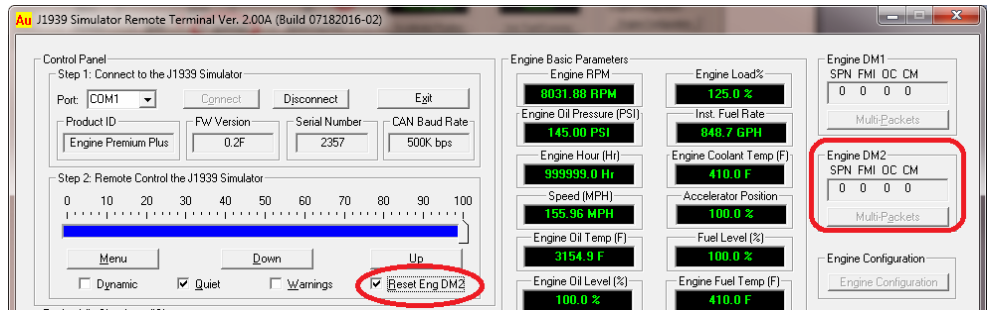

Figure 4-23 Reset Engine DM2

Detail data information of engine DM1 multi-packet is shown in Table 4 – 4 to 4 – 7.

Table 4 – 4 Engine DM1 Multi-Packets (1 – 16)

	1	2	3	4	5	6	7	8	9	10	11	12	13	14	15	16
SPN	110	100	97	94	168	157	174	175	111	558	626	1081	190	91	190	626
FMI	0	1	15	2	1	4	3	2	1	2	11	11	2	4	0	2
OC	1	5	9	13	17	21	25	29	33	37	41	45	49	53	57	61
CM	0	0	0	0	0	0	0	0	0	0	0	0	0	0	0	0

Table 4 – 5 Engine DM1 Multi-packets (17 – 32)

	17	18	19	20	21	22	23	24	25	26	27	28	29	30	31	32
SPN	190	558	16	626	51	52	72	94	108	102	111	174	1209	2791	176	175
FMI	10	3	4	8	3	3	3	4	4	4	3	2	4	3	2	3
OC	65	69	73	77	81	85	89	93	97	101	105	109	113	117	121	125
CM	0	0	0	0	0	0	0	0	0	0	0	0	0	0	0	0

Table 4 – 6 Engine DM1 Multi-Packets (33 – 48)

	33	34	35	36	37	38	39	40	41	42	43	44	45	46	47	48
SPN	102	102	102	102	102	102	102	102	102	102	102	102	102	102	102	102
FMI	0	1	2	3	4	5	6	7	8	9	10	11	12	13	14	15
OC	1	1	1	1	1	1	1	1	1	1	1	1	1	1	1	1
CM	0	0	0	0	0	0	0	0	0	0	0	0	0	0	0	0

Table 4 – 7 Engine DM1 Multi-Packets (49 – 64)

	49	50	51	52	53	54	55	56	57	58	59	60	61	62	63	64
SPN	102	102	102	102	102	102	102	102	102	102	102	102	102	102	102	102
FMI	16	17	18	19	20	21	22	23	24	25	26	27	28	29	30	31
OC	1	1	1	1	1	1	1	1	1	1	1	1	1	1	1	1
CM	0	0	0	0	0	0	0	0	0	0	0	0	0	0	0	0

4.12. Display Panel – Engine Configuration

Engine Configuration PGN includes 34 bytes of messages which require transport protocol for multi-packet communication. “Engine Configuration” button will be active on the GUI (Figure 4-24) for **Vehicle Platinum Edition(s)**.

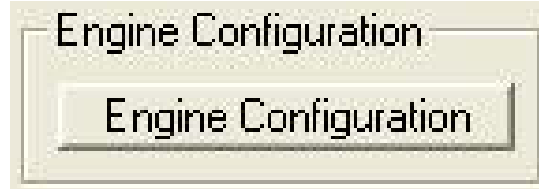

Figure 4-24 Engine Configuration is active (Vehicle Platinum Ed.)

Click "Engine Configuration" button will show detailed information (Figure 4-25).

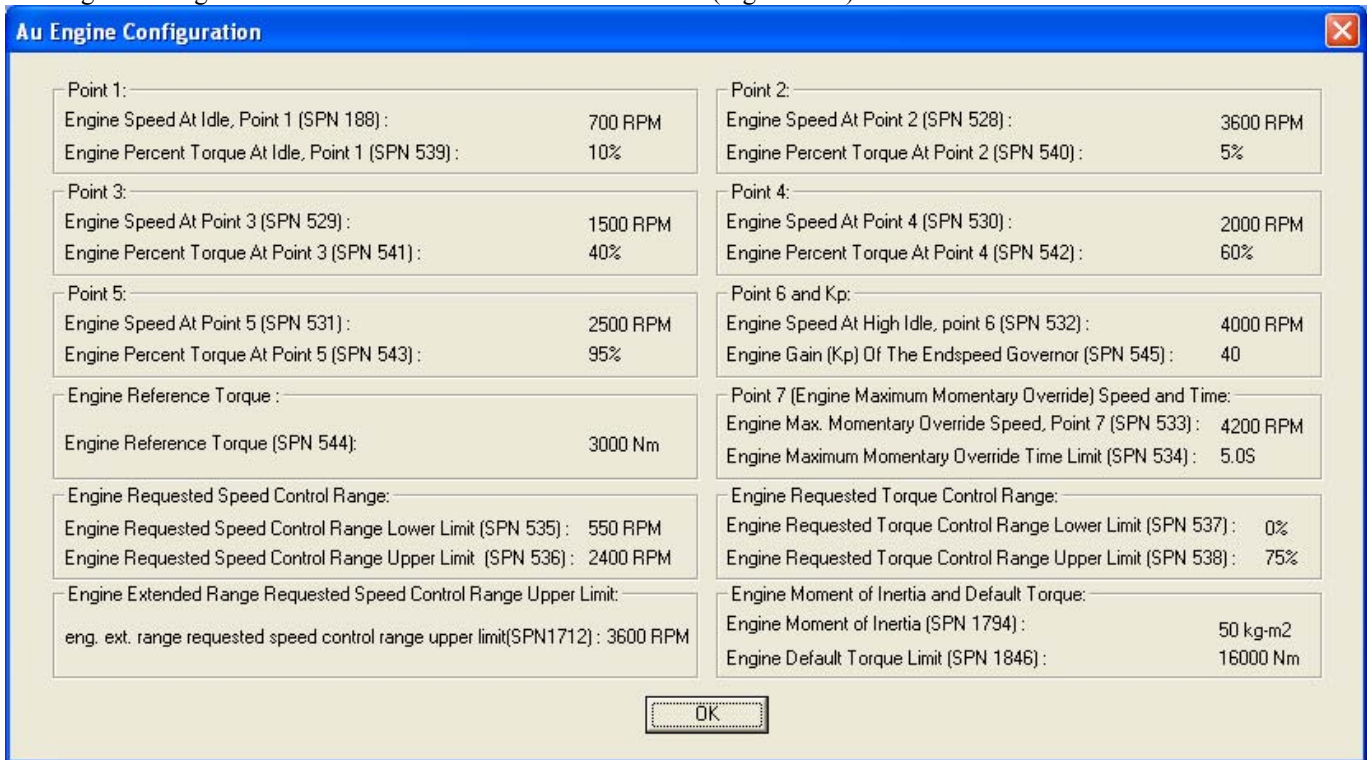

Figure 4-25 Display panel – Engine Configuration

4.13. Display Panel – Abs DM1

ABS DM1 is a single-packet PGN. If ABS warning is off, a SAE defined non-warning message will be shown as (0, 0, 0, 0). If ABS warning is on, a Brake Switch signal low warning will be shown as (597, 1, 7, 0) (Figure 4-26).



Figure 4-26 Display panel – ABS DM1

4.14. Display Panel – Transmission Dm1

Transmission DM1 is a single-packet PGN.

If transmission warning is off, a SAE defined non-warning message will be shown as (0, 0, 0, 0).

If the transmission warning is on, a transmission oil warning will be shown as (177, 0, 126, 0) (Figure 4-27).



Figure 4-27 Display panel – Transmission DM1



Chapter 5 Data Configuration

Table 5-1 lists some special simulation result at control step value of 0%, 20%, 40%, 60%, 80%, and 100%. Please refer to Table 5-9 through Table 5-18 for a complete list.

Table 5-1 SAE J1939 Simulation result vs. Control Step Values

J1939 Parameters	0%	20%	40%	60%	80%	100%
RPM (rpm)	0	1606.4	3212.8	4819.1	6425.5	8031.9
Engine Hour (Hr)	0	250	500	750	1000	999999
Vehicle Speed (MPH)	0	31.2	62.4	93.6	124.8	156
Engine Oil Pressure (PSI)	0	29	58	87	116	145
Engine Oil Temp (F)	-459.4	-40	104	248	392	3154.9
Engine Oil Level (%)	0.0%	20.0%	40.0%	60.0%	80.0%	100.0%
Engine Coolant Temp (F)	-40	50	140	230	320	410
Engine Coolant Pressure (PSI)	0	14.5	29	43.5	58	72.5
Engine Coolant Level (%)	0.0%	20.0%	40.0%	60.0%	80.0%	100.0%
Battery Voltage (V)	0	7.5	15	22.5	30	3212.8
Engine Boost Pressure (PSI)	0	14.5	29	43.5	58	72.5
Actual Engine % Torque	0	0.25	0.5	0.75	1	1.25
EGR Mass Flow Rate (Kg/Hr)	0	642.55	1285.1	1927.65	2570.2	3212.75
Accelerator Position (%)	0.0%	20.0%	40.0%	60.0%	80.0%	100.0%
Engine Load % (%)	0	0.25	0.5	0.75	1	1.25
Instant Fuel Economy (MPG)	0	22.5	45	67.5	90	295.2
Instant Fuel Rate (GPH)	0	15	30	45	60	848.7
Fuel Level (%)	0.0%	20.0%	40.0%	60.0%	80.0%	100.0%
Engine Fuel Temp (F)	-40	50	140	230	320	410
Inlet Air Temp (F)	-40	32	104	176	248	410
Exhaust Gas Temp (F)	-459.4	-44	371.3	786.7	1202	3154.9
Engine Trip (mile)	0	310.7	621.4	932.1	1242.7	621372.1
Total Vehicle Distance (mile)	0	621.4	1242.7	1864.1	2485.5	621372.1
Nominal Friction % Torque	0.0%	25.0%	50.0%	75.0%	100.0%	125.0%
Inlet Air Mass Flow Rate	0	642.55	1285.1	1927.65	2570.2	3212.75
Engine Air Inlet Pressure	0	14.5	29	43.5	58	72.5
Vehicle Identification (VIN)*3	0	*020	*030	*060	*080	*100
Transmission Oil Temp (F)*4	-459.4	-40	104	248	392	3154.9

- Note:**
1. Engine Clock is a self-running clock parameter, it will automatically change every minute.
 2. Cruise light will be on when control steps are larger than 40%.
 3. The first 14 digital bit of the 17-bit VIN number is "1M8GDM9AXKP042****", the last 3-bit changes from 000 to 100
 4. Transmission oil temp is **only** available for vehicle platinum edition and vehicle platinum plus edition.

For Engine Premium edition(s) and Vehicle Platinum edition(s), when the warning is turned on, changing the control step value will generate different warnings signals. The warning info will also be displayed on the remote terminal. The specific warning message, SPN, and FMI are listed in Table 5-2 for reference. When the warning is turned off, all Engine/ABS/Transmission DM1 warning will be off.

Table 5-2 Controlled Steps vs. "Engine IS lamps" ON status

Engine Idle Shutdown (IS)	Control Step Values
IS Timer ON	4, 5, 6, 7, 100%
IS Timer EN	0, 1, 2, 3, 4, 5, 6, 7, 8, 9, 10, 100%
IS Timer Override	9, 10, 100%
IS Shutdown Engine	2, 3, 100%
IS Driver Alert	4, 5, 100%



Table 5-3 Controlled Steps vs. "EPS lamps" ON status

Engine Protection System (EPS)	Control Step Values
EPS Timer ON	4, 5, 6, 7, 100%
EPS EN	0, 1, 2, 3, 4, 5, 6, 7, 8, 9, 10, 100%
EPS Timer Override	9, 10, 100%
EPS Shutdown Engine	2, 3, 100%
EPS Approaching Shutdown	4, 5, 100%

Table 5-4 Controlled Steps vs. Warning lamps, message, specific SPN, and FMI

Control Step value	Warning Lamps	Warning message	SPN	FMI
0%	Engine Amber	Low engine coolant level	111	1
1 - 9%	Engine Amber	Low battery electrical potential	168	1
10 - 19%	Engine (Amber + Red Stop)	Low battery electrical potential	168	1
20%	Engine (Amber + WIF)	Water in Fuel	97	15
21 - 29%	Engine Amber	Low engine oil pressure	100	1
30 - 39%	Engine (Amber + Red Stop)	Low engine oil pressure	100	1
40%	Engine Amber	High battery electrical potential	168	0
41 - 49%	Engine Amber	High engine coolant temperature	110	0
50 - 59%	Engine (Amber + Red Stop)	High engine coolant temperature	110	0
60%	Engine Amber	High engine oil pressure	100	0
61 - 69%	ABS Amber	Brake switch short	597	1
70 - 80%	ABS (Amber + Red Stop)	Brake switch short	597	1
81 - 89%	Transmission Amber	Transmission oil temperature high	177	0
90 - 99%	Transmission (Amber + Red Stop)	Transmission oil temperature high	177	0
100%	Engine (WIF +Red Stop + Amber) + ABS (Red Stop + Amber) +Transmission (Red Stop + Amber)	Engine DM1, DM2 multi-packets, ABS DM1 on, Transmission DM1 on		

Table 5-5 Controlled Steps vs. "Engine Basic Info lamps" ON status

Engine Information	Control Step Values
Wait to Start	0, 1, 2, 3, 4, 5, 100%
Overspeed Test	80, 100%
Air Shutoff	60, 100%
Alarm Output	20, 100%
Alarm Acknowledge	40, 100%
WIF	20, 100%
Engine Cruise Lamp Off	<40%
Engine Cruise Lamp On	>=40%

Table 5-6 Controlled Steps vs. "A/C & Refrigerant Switch" ON Status

A/C & Refrigerant Switch	Control Step Values
A/C High Pressure Fan Switch	20, 100%
Refrigerant Low Pressure Switch	40, 100%
Refrigerant High Pressure Switch	60, 100%

Au SAE J1939 Simulator Gen II 2.00A supported PGN, PGN description, and SPNs are listed in Table 5-7.



Table 5-7 List of PGN and function

PGNs	Description	Parameters	SPNs
54528	Time/Date Adjust (TDA)	Adjust minutes	1604
		Adjust hours	1605
59392	Acknowledgment	Positive Acknowledgment (ACK)	
		Negative Acknowledgment (NACK)	
59904	Request	Parameter Group Number (PGN) being requested	
60160	Transport Protocol-Data Transfer (TP.DT)	Sequence Number, Packetized Data	
60416	Transport Protocol-Connection Management (TP.CM)	Connection Mode Request to Send	TP.CM_RTS
		Connection Mode Clear to Send	TP.CM_CTS
		End of Message Acknowledgment	TP.CM_EndOfMsgACK
		Connection Abort	TP.Conn_Abort
		Broadcast Announce Message	TP.CM_BAM
60928	Address Claimed Message	Name of Controller Application	
61441	Electronic Brake Controller 1 (EBC1)	EBS Red Warning Signal	1439
		ABS/EBS Amber Warning Signal (Powered Vehicle)	1438
61442	Electronic Transmission Controller 1 (ETC1)	Source Address of Controlling Device for Transmission Control	1482
61443	Electronic Engine Controller 2 (EEC2)	Accelerator Pedal Position 1	91
		Engine Percent Load At Current Speed	92
61444	Electronic Engine Controller 1 (EEC1)	Actual Engine - Percent Torque	513
		Engine Speed	190
61450	Engine Gas Flow Rate (EGF1)	Engine Exhaust Gas Recirculation Mass Flow Rate	2659
		Engine Inlet Air Mass Flow Rate	132
65226	Active Diagnostic Trouble Codes (DTC) (DM1)	Red Stop Lamp	623
		Amber warning Lamp	624
		Engine DM1 Health-heart-beat	
65227	Previously Active Diagnostic Trouble Codes (DM2)	Red Stop Lamp	623
		Amber Warning Lamp Status	624
		Miscellaneous	
65228	Diagnostic data clear/reset of previously active DTCS (DM3)	On request using PGN 59904, See SAE J1939-21	
65247	Electronic Engine Controller 3 (EEC3)	Nominal Friction - Percent Torque	514
65248	Vehicle Distance (VD)	Trip Distance	244
		Total Vehicle Distance	245
65251	Engine Configuration (EC)	188, 528, 529, 530, 531, 532, 533, 534, 535, 536, 537, 538, 539, 540, 541, 542, 543, 544, 545, 1712, 1794, 1846	
65252	Shutdown	Engine IS has Shutdown Engine	593
		Engine IS Driver Alert Mode	594
		Engine IS Timer Override	592
		Engine IS (Idle Shutdown) Timer State	590
		Engine IS Timer Function	591
		A/C High Pressure Fan Switch	985
		Refrigerant Low Pressure Switch	875



		Refrigerant High Pressure Switch	605
		Engine Wait to Start Lamp	1081
		EPS has Shutdown Engine	1110
		EPS Approaching shutdown	1109
		EPS Timer Override	1108
		EPS (Engine Protection System)Timer State	1107
		EPS Configuration	1111
		Engine Alarm Acknowledge	2815
		Engine Alarm Output Command Status	2814
		Engine Air Shutoff Command Status	2813
		Engine Overspeed Test	2812
65253	Engine Hours, Revolutions (Hours)	Engine Total Hours of Operation	247
65254	Time/Date (TD)	Minutes	960
		Hours	961
65260	Vehicle Identification (VI)	Vehicle Identification Number	237
65262	Engine Temperature 1 (ET1)	Engine Coolant Temperature	110
		Engine Fuel Temperature (F)	174
		Engine Oil Temperature 1	175
65263	Engine Fluid Level / Pressure 1 (EFL/P1)	Engine Oil Level (%)	98
		Engine Oil Pressure	100
		Engine Coolant Pressure (PSI)	109
		Engine Coolant Level (%)	111
65265	Cruise Control / Vehicle Speed (CCVS)	Wheel-Based Vehicle Speed	84
		Cruise Control Active	595
65266	Fuel Economy (Liquid) (LFE)	Engine Fuel Rate	183
		Engine Instantaneous Fuel Economy	184
65270	Inlet/Exhaust Conditions 1 (IC1)	Engine Turbocharger Boost Pressure	102
		Engine Intake Manifold 1 Temperature	105
		Engine Air Inlet Pressure	106
		Engine Exhaust Gas Temperature	173
65271	Vehicle Electrical Power (VEP)	Electrical Potential (Voltage)	168
		Battery Potential (Voltage) Switched	158
65272	Transmission Fluids (TF)	Transmission Oil Temperature	177
65276	Dash Display (DD)	Fuel Level	96
65279	Water in Fuel Indicator (WIF)	Water In Fuel Indicator	97

As defined by SAE J1939-21, the Au SAE J1939 simulator responds to different "Vehicle Identification (VIN) request" and "engine DM2 request" with different transport protocols (illustrated in Table 5-8).

Table 5-8 Transport Protocol for VIN/DM2 global/specific request

Request	Transport Protocol
Global request	TP.CM.BAM
	TP.DT
Specific request	TP.CM.RTS
	TP.CM.CTS
	TP.DT
	TP.CM.EndofMessage
	TP.CM.Abort



The simulation result vs. control step value (from 0 to 100) is illustrated from Table 5-9 to Table 5-18.

Table 5-9 SAE J1939 Simulation result vs. control step values (from 1 to 10)

	0	1	2	3	4	5	6	7	8	9	10
RPM (rpm)	0	80.25	160.63	240.88	321.25	401.5	481.88	562.13	642.5	722.75	803.13
Engine Hour (Hr)	0	12.5	25	37.5	50	62.5	75	87.5	100	112.5	125
Vehicle Speed (MPH)	0	1.56	3.12	4.68	6.24	7.8	9.36	10.92	12.48	14.03	15.6
Engine Oil Pressure (PSI)	0	1.16	2.9	4.06	5.8	6.96	8.7	9.86	11.6	12.76	14.5
Engine Oil Temp (F)	-459.4	-438.5	-417.5	-396.5	-375.5	-354.5	-333.6	-312.6	-291.7	-270.7	-249.7
Engine Oil Level (%)	0	0.8	2	2.8	4	4.8	6	6.8	8	8.8	10
Engine Coolant Temp (F)	-40	-36.4	-31	-27.4	-22	-18.4	-13	-9.4	-4	-0.4	5
Engine Coolant Pressure (PSI)	0	0.58	1.45	2.03	2.9	3.48	4.35	4.93	5.8	6.38	7.25
Engine Coolant Level (%)	0	0.8	2	2.8	4	4.8	6	6.8	8	8.8	10
Battery Voltage (V)	0	0.35	0.75	1.1	1.5	1.85	2.25	2.6	3	3.35	3.75
Engine Boost Pressure (PSI)	0	0.6	1.4	2	2.9	3.5	4.3	4.9	5.8	6.4	7.3
Actual Engine % Torque	0	1	2	3	5	6	7	8	10	11	12
EGR Mass Flow Rate (Kg/Hr)	0	32.1	64.25	95.35	128.5	160.6	192.75	224.85	257	289.1	321.25
Accelerator Position (%)	0	0.8	2	2.8	4	4.8	6	6.8	8	8.8	10
Engine Load %	0	1	2	3	5	6	7	8	10	11	12
Instant Fuel Economy (MPG)	0	1.1	2.2	3.4	4.5	5.6	6.7	7.9	9	10.1	11.2
Instant Fuel Rate (GPH)	0	0.7	1.5	2.2	3	3.7	4.5	5.2	6	6.7	7.5
Fuel Level (%)	0	0.8	2	2.8	4	4.8	6	6.8	8	8.8	10
Engine Fuel Temp (F)	-40	-36.4	-31	-27.4	-22	-18.4	-13	-9.4	-4	-0.4	5
Inlet Air Temp (F)	-40	-36.4	-32.8	-29.2	-25.6	-22	-18.4	-14.8	-11.2	-7.6	-4
Exhaust Gas Temp (F)	-459.4	-438.6	-417.9	-397.1	-376.4	-355.6	-334.8	-314	-294.3	-272.5	-251.7
Engine Trip (mile)	0	15.5	31.1	46.6	62.1	77.7	93.2	108.7	124.3	139.8	155.3
Total Vehicle Distance (mile)	0	31.1	62.1	93.2	124.3	155.3	186.4	217.5	248.5	279.6	310.7
Nominal Friction % Torque	0	1	2	3	5	6	7	8	10	11	12
Inlet Air Mass Flow Rate	0	32.1	64.25	95.35	128.5	160.6	192.75	224.85	257	289.1	321.25
Engine Air Inlet Pressure	0	0.6	1.4	2	2.9	3.5	4.3	4.9	5.8	6.4	7.3
Vehicle Identification (VIN)	*000	*001	*002	*003	*004	*005	*006	*007	*008	*009	*010
Transmission Oil Temp (F)	-459.4	-438.5	-417.5	-396.5	-375.5	-354.5	-333.6	-312.6	-291.7	-270.7	-249.7



Table 5-10 SAE J1939 Simulation result vs. control step values (from 11 to 20)

	11	12	13	14	15	16	17	18	19	20
RPM (rpm)	883.5	963.75	1044.13	1124.38	1204.75	1285	1365.38	1445.63	1526	1606.38
Engine Hour (Hr)	137.5	150	162.5	175	187.5	200	212.5	225	237.5	250
Vehicle Speed (MPH)	17.16	18.71	20.27	21.83	23.39	24.95	26.51	28.07	29.63	31.19
Engine Oil Pressure(PSI)	15.66	17.4	18.56	20.3	21.46	23.2	24.36	26.1	27.26	29
Engine Oil Temp (F)	-228.8	-207.8	-186.8	-165.8	-144.9	-123.9	-102.9	-82	-61	-40
Engine Oil Level (%)	10.8	12	12.8	14	14.8	16	16.8	18	18.8	20
Engine Coolant Temp (F)	8.6	14	17.6	23	26.6	32	35.6	41	44.6	50
Engine Coolant Pressure (PSI)	7.83	8.7	9.28	10.15	10.73	11.6	12.18	13.05	13.63	14.5
Engine Coolant Level (%)	10.8	12	12.8	14	14.8	16	16.8	18	18.8	20
Battery Voltage (V)	4.1	4.5	4.85	5.25	5.6	6	6.35	6.75	7.1	7.5
Engine Boost Pressure (PSI)	7.8	8.7	9.3	10.1	10.7	11.6	12.2	13	13.6	14.5
Actual Engine % Torque	13	15	16	17	18	20	21	22	23	25
EGR Mass Flow Rate (Kg/Hr)	353.4	385.5	417.65	449.75	481.9	514	546.15	578.25	610.4	642.55
Accelerator Position (%)	10.8	12	12.8	14	14.8	16	16.8	18	18.8	20
Engine Load %	13	15	16	17	18	20	21	22	23	25
Instant Fuel Economy (MPG)	12.4	13.5	14.6	15.7	16.9	18	19.1	20.2	21.4	22.5
Instant Fuel Rate (GPH)	8.2	9	9.7	10.5	11.2	12	12.7	13.5	14.2	15
Fuel Level (%)	10.8	12	12.8	14	14.8	16	16.8	18	18.8	20
Engine Fuel Temp (F)	8.6	14	17.6	23	26.6	32	35.6	41	44.6	50
Inlet Air Temp (F)	-0.4	3.2	6.8	10.4	14	17.6	21.2	24.8	28.4	32
Exhaust Gas Temp (F)	-231	-210.2	-189.5	-168.7	-147.9	-127.1	-106.4	-85.6	-64.9	-44
Engine Trip (mile)	170.9	186.4	201.9	217.5	233	248.5	264.1	279.6	295.2	310.7
Total Vehicle Distance (mile)	341.8	372.8	403.9	435	466	497.1	528.2	559.2	590.3	621.4
Nominal Friction % Torque	13	15	16	17	18	20	21	22	23	25
Inlet Air Mass Flow Rate	353.4	385.5	417.65	449.75	481.9	514	546.15	578.25	610.4	642.55
Engine Air Inlet Pressure	7.8	8.7	9.3	10.1	10.7	11.6	12.2	13	13.6	14.5
Vehicle Identification (VIN)	*011	*012	*013	*014	*015	*016	*017	*018	*019	*020
Transmission Oil Temp (F)	-228.8	-207.8	-186.8	-165.8	-144.9	-123.9	-102.9	-82	-61	-40



Table 5-11 SAE J1939 Simulation result vs. control step values (from 21 to 30)

	21	22	23	24	25	26	27	28	29	30
RPM (rpm)	1686.63	1767	1847.25	1927.63	2007.88	2088.25	2168.5	2248.88	2329.13	2409.5
Engine Hour (Hr)	262.5	275	287.5	300	312.5	325	337.5	350	362.5	375
Vehicle Speed (MPH)	32.75	34.31	35.87	37.43	38.99	40.55	42.11	43.67	45.23	46.79
Engine Oil Pressure (PSI)	30.16	31.9	33.06	34.8	35.96	37.7	38.86	40.6	41.76	43.5
Engine Oil Temp (F)	-32.8	-25.6	-18.4	-11.2	-4	3.2	10.4	17.6	24.8	32
Engine Oil Level (%)	20.8	22	22.8	24	24.8	26	26.8	28	28.8	30
Engine Coolant Temp (F)	53.6	59	62.6	68	71.6	77	80.6	86	89.6	95
Engine Coolant Pressure (PSI)	15.08	15.95	16.53	17.4	17.98	18.85	19.43	20.3	20.88	21.75
Engine Coolant Level (%)	20.8	22	22.8	24	24.8	26	26.8	28	28.8	30
Battery Voltage (V)	7.85	8.25	8.6	9	9.35	9.75	10.1	10.5	10.85	11.25
Engine Boost Pressure (PSI)	15.1	15.9	16.5	17.4	18	18.9	19.4	20.3	20.9	21.8
Actual Engine % Torque	26	27	28	30	31	32	33	35	36	37
EGR Mass Flow Rate (Kg/Hr)	674.65	706.8	738.9	771.05	803.15	835.3	867.4	899.55	931.65	963.8
Accelerator Position (%)	20.8	22	22.8	24	24.8	26	26.8	28	28.8	30
Engine Load %	26	27	28	30	31	32	33	35	36	37
Instant Fuel Economy (MPG)	23.6	24.7	25.9	27	28.1	29.2	30.4	31.5	32.6	33.7
Instant Fuel Rate (GPH)	15.7	16.5	17.2	18	18.7	19.5	20.2	21	21.7	22.5
Fuel Level (%)	20.8	22	22.8	24	24.8	26	26.8	28	28.8	30
Engine Fuel Temp (F)	53.6	59	62.6	68	71.6	77	80.6	86	89.6	95
Inlet Air Temp (F)	35.6	39.2	42.8	46.4	50	53.6	57.2	60.8	64.4	68
Exhaust Gas Temp (F)	-23.3	-2.5	18.2	39	59.8	80.5	101.3	122.1	142.8	163.6
Engine Trip (mile)	326.2	341.8	357.3	372.8	388.4	403.9	419.4	435	450.5	466
Total Vehicle Distance (mile)	652.4	683.5	714.6	745.6	776.7	807.8	838.9	869.9	901	932.1
Nominal Friction % Torque	26	27	28	30	31	32	33	35	36	37
Inlet Air Mass Flow Rate	674.65	706.8	738.9	771.05	803.15	835.3	867.4	899.55	931.65	963.8
Engine Air Inlet Pressure	15.1	15.9	16.5	17.4	18	18.9	19.4	20.3	20.9	21.8
Vehicle Identification (VIN)	*021	*022	*023	*024	*025	*026	*027	*028	*029	*030
Transmission Oil Temp (F)	-32.8	-25.6	-18.4	-11.2	-4	3.2	10.4	17.6	24.8	32



Table 5-12 SAE J1939 Simulation result vs. control step values (from 31 to 40)

	31	32	33	34	35	36	37	38	39	40
RPM (rpm)	2489.88	2570.13	2650.5	2730.75	2811.13	2891.38	2971.75	3052	3132.38	3212.75
Engine Hour (Hr)	387.5	400	412.5	425	437.5	450	462.5	475	487.5	500
Vehicle Speed (MPH)	48.35	49.91	51.47	53.03	54.59	56.14	57.71	59.26	60.82	62.38
Engine Oil Pressure (PSI)	44.66	46.4	47.56	49.3	50.46	52.2	53.36	55.1	56.26	58
Engine Oil Temp (F)	39.2	46.4	53.6	60.8	68	75.2	82.4	89.6	96.8	104
Engine Oil Level (%)	30.8	32	32.8	34	34.8	36	36.8	38	38.8	40
Engine Coolant Temp (F)	98.6	104	107.6	113	116.6	122	125.6	131	134.6	140
Engine Coolant Pressure (PSI)	22.33	23.2	23.78	24.65	25.23	26.1	26.68	27.55	28.13	29
Engine Coolant Level (%)	30.8	32	32.8	34	34.8	36	36.8	38	38.8	40
Battery Voltage (V)	11.6	12	12.35	12.75	13.1	13.5	13.85	14.25	14.6	15
Engine Boost Pressure (PSI)	22.3	23.2	23.8	24.6	25.2	26.1	26.7	27.5	28.1	29
Actual Engine % Torque	38	40	41	42	43	45	46	47	48	50
EGR Mass Flow Rate (Kg/Hr)	995.95	1028.05	1060.2	1092.3	1124.45	1156.55	1088.7	1220.8	1252.95	1285.1
Accelerator Position (%)	30.8	32	32.8	34	34.8	36	36.8	38	38.8	40
Engine Load %	38	40	41	42	43	45	46	47	48	50
Instant Fuel Economy (MPG)	34.9	36	37.1	38.2	39.4	40.5	41.6	42.7	43.9	45
Instant Fuel Rate (GPH)	23.2	24	24.7	25.5	26.2	27	27.7	28.5	29.2	30
Fuel Level (%)	30.8	32	32.8	34	34.8	36	36.8	38	38.8	40
Engine Fuel Temp (F)	98.6	104	107.6	113	116.6	122	125.6	131	134.6	140
Inlet Air Temp (F)	71.6	75.2	78.8	82.4	86	89.6	93.2	96.8	100.4	104
Exhaust Gas Temp (F)	184.4	205.1	225.9	246.6	267.5	288.2	309	329.7	350.5	371.3
Engine Trip (mile)	481.6	497.1	512.6	528.2	543.7	559.2	574.8	590.3	605.8	621.4
Total Vehicle Distance (mile)	963.1	994.2	1025.3	1056.3	1087.4	1118.5	1149.5	1180.6	1211.7	1242.7
Nominal Friction % Torque	38	40	41	42	43	45	46	47	48	50
Inlet Air Mass Flow Rate	995.95	1028.05	1060.2	1092.3	1124.45	1156.55	1088.7	1220.8	1252.95	1285.1
Engine Air Inlet Pressure	22.3	23.2	23.8	24.6	25.2	26.1	26.7	27.5	28.1	29
Vehicle Identification (VIN)	*031	*032	*033	*034	*035	*036	*037	*038	*039	*040
Transmission Oil Temp (F)	39.2	46.4	53.6	60.8	68	75.2	82.4	89.6	96.8	104



Table 5-13 SAE J1939 Simulation result vs. control step values (from 41 to 50)

	41	42	43	44	45	46	47	48	49	50
RPM (rpm)	3293	3373.38	3453.63	3534	3614.25	3694.63	3774.88	3855.25	3935.5	4015.88
Engine Hour (Hr)	512.5	525	537.5	550	562.5	575	587.5	600	612.5	625
Vehicle Speed (MPH)	63.94	65.5	67.06	68.62	70.18	71.74	73.3	74.86	76.42	77.98
Engine Oil Pressure (PSI)	59.16	60.9	62.06	63.8	64.96	66.7	67.86	69.6	70.76	72.5
Engine Oil Temp (F)	111.2	118.4	125.6	132.8	140	147.2	154.4	161.6	168.8	176
Engine Oil Level (%)	40.8	42	42.8	44	44.8	46	46.8	48	48.8	50
Engine Coolant Temp (F)	143.6	149	152.6	158	161.6	167	170.6	176	179.6	185
Engine Coolant Pressure (PSI)	29.58	30.45	31.03	31.9	32.48	33.35	33.93	34.8	35.38	36.25
Engine Coolant Level (%)	40.8	42	42.8	44	44.8	46	46.8	48	48.8	50
Battery Voltage (V)	15.35	15.75	16.1	16.5	16.85	17.25	17.6	18	18.35	18.75
Engine Boost Pressure (PSI)	29.6	30.4	31	31.9	32.5	33.3	33.9	34.8	35.4	36.3
Actual Engine % Torque	51	52	53	55	56	57	58	60	61	62
EGR Mass Flow Rate (Kg/Hr)	1317.2	1349.35	1381.45	1413.6	1445.7	1477.85	1509.95	1542.1	1574.2	1606.35
Accelerator Position (%)	40.8	42	42.8	44	44.8	46	46.8	48	48.8	50
Engine Load %	51	52	53	55	56	57	58	60	61	62
Instant Fuel Economy (MPG)	46.1	47.2	48.4	49.5	50.6	51.7	52.9	54	55.1	56.2
Instant Fuel Rate (GPH)	30.7	31.5	32.2	33	33.7	34.5	35.2	36	36.7	37.5
Fuel Level (%)	40.8	42	42.8	44	44.8	46	46.8	48	48.8	50
Engine Fuel Temp (F)	143.6	149	152.6	158	161.6	167	170.6	176	179.6	185
Inlet Air Temp (F)	107.6	111.2	114.8	118.4	122	125.6	129.2	132.8	136.4	140
Exhaust Gas Temp (F)	392.1	412.8	433.6	454.3	475.1	495.9	516.7	537.4	558.2	579
Engine Trip (mile)	636.9	652.4	668	683.5	699	714.6	730.1	745.6	761.2	776.7
Total Vehicle Distance (mile)	1273.8	1304.9	1336	1367	1398.1	1429.2	1460.2	1491.3	1522.4	1553.4
Nominal Friction % Torque	51	52	53	55	56	57	58	60	61	62
Inlet Air Mass Flow Rate	1317.2	1349.35	1381.45	1413.6	1445.7	1477.85	1509.95	1542.1	1574.2	1606.35
Engine Air Inlet Pressure	29.6	30.4	31	31.9	32.5	33.3	33.9	34.8	35.4	36.3
Vehicle Identification (VIN)	*041	*042	*043	*044	*045	*046	*047	*048	*049	*050
Transmission Oil Temp (F)	111.2	118.4	125.6	132.8	140	147.2	154.4	161.6	168.8	176



Table 5-14 SAE J1939 Simulation result vs. control step values (from 51 to 60)

	51	52	53	54	55	56	57	58	59	60
RPM (rpm)	4096.25	4176.5	4256.88	4337.13	4417.5	4497.75	4578.13	4685.38	4738.75	4819.13
Engine Hour (Hr)	637.5	650	662.5	675	687.5	700	712.5	725	737.5	750
Vehicle Speed (MPH)	79.54	81.1	82.66	84.22	85.78	87.34	88.9	90.46	92.02	93.58
Engine Oil Pressure (PSI)	73.66	75.4	76.56	78.3	79.46	81.2	82.36	84.1	85.26	87
Engine Oil Temp (F)	183.2	190.4	197.6	204.8	212	219.2	226.4	233.6	240.8	248
Engine Oil Level (%)	50.8	52	52.8	54	54.8	56	56.8	58	58.8	60
Engine Coolant Temp (F)	188.6	194	197.6	203	206.6	212	215.6	221	244.6	230
Engine Coolant Pressure (PSI)	36.83	37.7	38.28	39.15	39.73	40.6	41.18	42.05	42.63	43.5
Engine Coolant Level (%)	50.8	52	52.8	54	54.8	56	56.8	58	58.8	60
Battery Voltage (V)	19.1	19.5	19.85	20.25	20.6	21	21.35	21.75	22.1	22.5
Engine Boost Pressure (PSI)	36.8	37.7	38.3	39.1	39.7	40.6	41.2	42	42.6	43.5
Actual Engine % Torque	63	65	66	67	68	70	71	72	73	75
EGR Mass Flow Rate (Kg/Hr)	1638.5	1670.6	1072.75	1734.85	1767	1799.1	1831.25	1863.35	1895.5	1927.65
Accelerator Position (%)	50.8	52	52.8	54	54.8	56	56.8	58	58.8	60
Engine Load %	63	65	66	67	68	70	71	72	73	75
Instant Fuel Economy (MPG)	57.4	58.5	59.6	60.7	61.9	63	64.1	65.2	66.4	67.5
Instant Fuel Rate (GPH)	38.2	39	39.7	40.5	41.2	42	42.7	43.5	44.2	45
Fuel Level (%)	50.8	52	52.8	54	54.8	56	56.8	58	58.8	60
Engine Fuel Temp (F)	188.6	194	197.6	203	206.6	212	215.6	221	244.6	230
Inlet Air Temp (F)	143.6	147.2	150.8	154.4	158	161.6	165.2	168.8	172.4	176
Exhaust Gas Temp (F)	599.7	620.5	641.2	662	682.8	703.6	724.1	745.1	765.8	786.7
Engine Trip (mile)	792.3	807.8	823.3	838.9	854.4	869.6	885.5	901	916.5	932.1
Total Vehicle Distance (mile)	1584.5	1615.6	1646.6	1677.7	1708.8	1739.8	1770.9	1802	1833	1864.1
Nominal Friction % Torque	63	65	66	67	68	70	71	72	73	75
Inlet Air Mass Flow Rate	1638.5	1670.6	1072.75	1734.85	1767	1799.1	1831.25	1863.35	1895.5	1927.65
Engine Air Inlet Pressure	36.8	37.7	38.3	39.1	39.7	40.6	41.2	42	42.6	43.5
Vehicle Identification (VIN)	*051	*052	*053	*054	*055	*056	*057	*058	*059	*060
Transmission Oil Temp (F)	183.2	190.4	197.6	204.8	212	219.2	226.4	233.6	240.8	248



Table 5-15 SAE J1939 Simulation result vs. control step values (from 61 to 70)

	61	62	63	64	65	66	67	68	69	70
RPM (rpm)	4899.38	4979.75	5060	5140.38	5220.63	5301	5381.25	5461.63	5541.88	5622.25
Engine Hour (Hr)	762.5	775	787.5	800	812.5	825	837.5	850	862.5	875
Vehicle Speed (MPH)	95.14	96.7	98.25	99.82	101.37	102.93	104.49	106.05	107.61	109.17
Engine Oil Pressure (PSI)	88.16	89.9	91.06	92.8	93.96	95.7	96.86	98.6	99.76	101.5
Engine Oil Temp (F)	255.2	262.4	269.6	276.8	284	291.2	298.4	305.6	312.8	320
Engine Oil Level (%)	60.8	62	62.8	64	64.8	66	66.8	68	68.8	70
Engine Coolant Temp (F)	233.6	239	242.6	248	251.6	257	260.6	266	269.6	275
Engine Coolant Pressure (PSI)	44.08	44.95	45.63	46.4	46.98	47.85	48.43	49.3	49.88	50.75
Engine Coolant Level (%)	60.8	62	62.8	64	64.8	66	66.8	68	68.8	70
Battery Voltage (V)	22.85	23.25	23.6	24	24.35	24.75	25.1	25.5	25.85	26.25
Engine Boost Pressure (PSI)	44.1	44.9	45.5	46.4	47	47.8	48.4	49.3	49.9	50.8
Actual Engine % Torque	76	77	78	80	81	82	83	85	86	87
EGR Mass Flow Rate (Kg/Hr)	1959.75	1991.9	2024	2056.15	2088.25	2120.4	2152.5	2184.65	2216.75	2248.9
Accelerator Position (%)	60.8	62	62.8	64	64.8	66	66.8	68	68.8	70
Engine Load %	76	77	78	80	81	82	83	85	86	87
Instant Fuel Economy (MPG)	68.6	69.7	70.9	72	73.1	74.2	75.4	76.5	77.6	78.7
Instant Fuel Rate (GPH)	45.7	46.5	47.2	48	48.7	49.5	50.2	51	51.7	52.5
Fuel Level (%)	60.8	62	62.8	64	64.8	66	66.8	68	68.8	70
Engine Fuel Temp (F)	233.6	239	242.6	248	251.6	257	260.6	266	269.6	275
Inlet Air Temp (F)	179.6	183.2	186.8	190.4	194	197.6	201.2	204.8	208.4	212
Exhaust Gas Temp (F)	807.4	828.2	848.9	869.7	890.5	911.2	932	952.8	973.5	994.3
Engine Trip (mile)	947.6	963.1	978.7	994.2	1009.7	1025.3	1040.8	1056.3	1071.9	1087.4
Total Vehicle Distance (mile)	1895.2	1926.3	1957.3	1988.4	2019.5	2050.5	2081.6	2112.7	2143.7	2174.8
Nominal Friction % Torque	76	77	78	80	81	82	83	85	86	87
Inlet Air Mass Flow Rate	1959.75	1991.9	2024	2056.15	2088.25	2120.4	2152.5	2184.65	2216.75	2248.9
Engine Air Inlet Pressure	44.1	44.9	45.5	46.4	47	47.8	48.4	49.3	49.9	50.8
Vehicle Identification (VIN)	*061	*062	*063	*064	*065	*066	*067	*068	*069	*070
Transmission Oil Temp (F)	255.2	262.4	269.6	276.8	284	291.2	298.4	305.6	312.8	320



Table 5-16 SAE J1939 Simulation result vs. control step values (from 71 to 80)

	71	72	73	74	75	76	77	78	79	80
RPM (rpm)	5702.63	5782.88	5863.25	5943.5	6023.88	6104.13	6184.5	6264.75	6345.13	6425.5
Engine Hour (Hr)	887.5	900	912.5	925	937.5	950	962.5	975	987.5	1000
Vehicle Speed (MPH)	110.73	112.29	113.85	115.41	116.97	118.53	120.09	121.65	123.21	124.77
Engine Oil Pressure (PSI)	102.66	104.4	105.56	107.3	108.46	110.2	111.36	113.1	114.26	116
Engine Oil Temp (F)	327.2	334.4	341.6	348.8	356	363.2	370.4	377.6	384.8	392
Engine Oil Level (%)	70.8	72	72.8	74	74.8	76	76.8	78	78.8	80
Engine Coolant Temp (F)	278.6	284	287.6	293	296.6	302	305.6	311	314.6	320
Engine Coolant Pressure (PSI)	51.33	52.2	52.78	53.65	54.23	55.1	55.68	56.5	57.13	58
Engine Coolant Level (%)	70.8	72	72.8	74	74.8	76	76.8	78	78.8	80
Battery Voltage (V)	26.6	27	27.35	27.75	28.1	28.5	28.85	29.25	29.6	30
Engine Boost Pressure (PSI)	51.3	52.2	52.8	53.6	54.2	55.1	55.7	56.5	57.1	58
Actual Engine % Torque	88	90	91	92	93	95	96	97	98	100
EGR Mass Flow Rate (Kg/Hr)	2281.05	2313.15	2345.3	2377.4	2409.55	2441.65	2473.8	2505.9	2538.05	2570.2
Accelerator Position (%)	70.8	72	72.8	74	74.8	76	76.8	78	78.8	80
Engine Load %	88	90	91	92	93	95	96	97	98	100
Instant Fuel Economy (MPG)	79.9	81	82.1	83.2	84.4	85.5	86.6	87.7	88.9	90
Instant Fuel Rate (GPH)	53.2	54	54.7	55.5	56.2	57	57.7	58.5	59.2	60
Fuel Level (%)	70.8	72	72.8	74	74.8	76	76.8	78	78.8	80
Engine Fuel Temp (F)	278.6	284	287.6	293	296.6	302	305.6	311	314.6	320
Inlet Air Temp (F)	215.6	219.2	222.8	226.4	230	233.6	237.2	240.8	244.4	248
Exhaust Gas Temp (F)	1015.1	1035.8	1056.6	1077.3	1098.2	1118.9	1139.7	1060.4	1181.2	1202
Engine Trip (mile)	1102.9	1118.5	1134	1149.5	1165.1	1180.6	1196.1	1211.7	1227.2	1242.7
Total Vehicle Distance (mile)	2205.9	2236.9	2268	2299.1	2330.1	2361.2	2392.3	2423.4	2454.4	2485.5
Nominal Friction % Torque	88	90	91	92	93	95	96	97	98	100
Inlet Air Mass Flow Rate	2281.05	2313.15	2345.3	2377.4	2409.55	2441.65	2473.8	2505.9	2538.05	2570.2
Engine Air Inlet Pressure	51.3	52.2	52.8	53.6	54.2	55.1	55.7	56.5	57.1	58
Vehicle Identification (VIN)	*071	*072	*073	*074	*075	*076	*077	*078	*079	*080
Transmission Oil Temp (F)	327.2	334.4	341.6	348.8	356	363.2	370.4	377.6	384.8	392



Table 5-17 SAE J1939 Simulation result vs. control step values (from 81 to 90)

	81	82	83	84	85	86	87	88	89	90
RPM (rpm)	6505.75	6586.13	6666.38	6746.75	6827	6907.38	6987.63	7068	7148.25	7228.63
Engine Hour (Hr)	50950	100899.9	150849.8	200799.8	250749.7	300699.7	350649.6	400599.6	450549.5	500499.5
Vehicle Speed (MPH)	126.33	127.89	129.45	131.01	132.57	134.13	135.68	137.25	138.8	140.36
Engine Oil Pressure (PSI)	117.16	118.9	120.06	121.8	122.96	124.7	125.86	127.6	128.76	130.5
Engine Oil Temp (F)	530.1	668.2	806.4	944.5	1082.7	1220.8	1359	1497.1	1635.3	1773.4
Engine Oil Level (%)	80.8	82	82.8	84	85.8	86	86.8	88	88.8	90
Engine Coolant Temp (F)	323.6	329	332.6	338	341.6	347	350.6	356	359.6	365
Engine Coolant Pressure (PSI)	58.58	59.45	60.03	60.9	61.48	62.35	62.93	63.8	64.38	65.25
Engine Coolant Level (%)	80.8	82	82.8	84	84.8	86	86.8	88	88.8	90
Battery Voltage (V)	33	36	39	42	45	48	51	54	57	60
Engine Boost Pressure (PSI)	58.6	59.4	60	60.9	61.5	62.3	62.9	63.8	64.4	65.3
Actual Engine % Torque	101	102	103	105	106	107	108	110	111	112
EGR Mass Flow Rate(Kg/Hr)	2602.3	2634.45	2666.55	2698.7	2730.8	2762.95	2795.05	2827.2	2859.3	2891.45
Accelerator Position (%)	80.8	82	82.8	84	84.8	86	86.8	88	88.8	90
Engine Load %	101	102	103	105	106	107	108	110	111	112
Instant Fuel Economy (MPG)	100.3	110.5	120.8	131	141.3	151.6	161.8	172.1	182.3	192.6
Instant Fuel Rate (GPH)	99.4	138.9	178.3	217.7	257.2	296.6	336	375.5	414.9	454.3
Fuel Level (%)	80.8	82	82.8	84	85.8	86	86.8	88	88.8	90
Engine Fuel Temp (F)	323.6	329	332.6	338	341.6	347	350.6	356	359.6	365
Inlet Air Temp (F)	255.2	264.2	271.4	280.4	287.6	296.6	303.8	312.8	320	329
Exhaust Gas Temp (F)	1299.6	1397.2	1494.9	1592.5	1690.2	1087.8	1885.5	1983.1	2080.8	2178.4
Engine Trip (mile)	32249.2	63255.7	94262.1	125268.6	156275.1	187281.5	218288	249494.4	280300.9	311307.4
Total Vehicle Distance (mile)	33429.8	64374.1	95318.4	126262.8	157207.1	188151.4	219095.8	250040.1	280984.4	311928.8
Nominal Friction % Torque	101	102	103	105	106	107	108	110	111	112
Inlet Air Mass Flow Rate	2602.3	2634.45	2666.55	2698.7	2730.8	2762.95	2795.05	2827.2	2859.3	2891.45
Engine Air Inlet Pressure	58.6	59.4	60	60.9	61.5	62.3	62.9	63.8	64.4	65.3
Vehicle Identification (VIN)	*081	*082	*083	*084	*085	*086	*087	*088	*089	*090
Transmission Oil Temp (F)	530.1	668.2	806.4	944.5	1082.7	1220.8	1359	1497.1	1635.3	1773.4



Table 5-18 SAE J1939 Simulation result vs. control step values (from 91 to 100)

	91	92	93	94	95	96	97	98	99	100
RPM (rpm)	7309	7389.25	7469.63	7549.88	7630.25	7710.5	7790.88	7871.13	7951.5	8031.88
Engine Hour (Hr)	550449.4	600399.4	650349.3	700299.3	750249.2	800199.2	850149.2	900099.1	950049	999999
Vehicle Speed (MPH)	141.93	143.48	145.04	146.6	148.16	149.72	151.28	152.84	154.4	155.96
Engine Oil Pressure (PSI)	131.66	133.4	134.56	136.3	137.46	139.2	140.36	142.1	143.26	145
Engine Oil Temp (F)	1911.6	2049.7	2187.9	2326	2464.2	2602.3	2740.5	2878.6	3016.8	3154.9
Engine Oil Level (%)	90.8	92	92.8	94	94.8	96	96.8	98	98.8	100
Engine Coolant Temp (F)	368.6	374	377.6	383	386.6	392	395.6	401	404.6	410
Engine Coolant Pressure (PSI)	65.83	66.7	67.28	68.15	68.73	69.6	70.18	71.05	71.63	72.5
Engine Coolant Level (%)	90.8	92	92.8	94	94.8	96	96.8	98	98.8	100
Battery Voltage (V)	375.25	690.55	1005.8	1321.1	1636.35	1951.65	2266.9	2582.2	2897.45	3212.75
Engine Boost Pressure (PSI)	65.8	66.7	67.3	68.2	68.7	69.6	70.2	71	71.6	72.5
Actual Engine % Torque	113	115	116	117	118	120	121	122	123	125
EGR Mass Flow Rate (Kg/Hr)	2923.6	2955.7	2987.85	3019.95	3052.1	3084.2	3116.35	3148.45	3180.6	3212.75
Accelerator Position (%)	90.8	92	92.8	94	94.8	96	96.8	98	98.8	100
Engine Load %	113	115	116	117	118	120	121	122	123	125
Instant Fuel Economy (MPG)	202.8	213.1	223.4	233.6	243.9	254.2	264.4	274.7	284.9	295.2
Instant Fuel Rate (GPH)	493.8	533.2	572.7	612.1	651.5	691	730.4	769.8	809.3	848.7
Fuel Level (%)	90.8	92	92.8	94	94.8	96	96.8	98	98.8	100
Engine Fuel Temp (F)	368.6	374	377.6	383	386.6	392	395.6	401	404.6	410
Inlet Air Temp (F)	336.2	345.2	352.4	361.4	368.6	377.6	384.8	393.8	401	410
Exhaust Gas Temp (F)	2276.1	2373.7	2471.4	2569	2666.7	2764.1	2862	2959.6	3057.3	3154.9
Engine Trip (mile)	342313.9	373320.4	404326.8	435333.3	466339.8	497346.2	528352.7	559359.1	590365.6	621372.1
Total Vehicle Distance (mile)	342873.1	373817.5	404761.7	435706.1	466650.5	497594.7	528539.1	559483.4	590427.8	621372.1
Nominal Friction % Torque	113	115	116	117	118	120	121	122	123	125
Inlet Air Mass Flow Rate	2923.6	2955.7	2987.85	3019.95	3052.1	3084.2	3116.35	3148.45	3180.6	3212.75
Engine Air Inlet Pressure	65.8	66.7	67.3	68.2	68.7	69.6	70.2	71	71.6	72.5
Vehicle Identification (VIN)	*091	*092	*093	*094	*095	*096	*097	*098	*099	*100
Transmission Oil Temp (F)	1911.6	2049.7	2187.9	2326	2464.2	2602.3	2740.5	2878.6	3016.8	3154.9

Appendix A - Remote Terminal Installation Guide

A remote terminal program can be used to control and display detail information of simulated SAE J1939 signals on a PC screen.

A.1. What you need before install Au J1939 Simulator Remote Terminal

1. A "Plus" edition of Au SAE J1939 Simulator (Engine Basic plus Edition or Engine Premium plus edition or Vehicle Platinum plus Edition).
2. PC software: The installation program "AU setup J1939 Simulator Remote Terminal V1.00A" will be provided when Au SAE-J1939 Simulator is ordered.
3. A PC equipped with serial port, with a serial extension cable
4. Or a PC equipped with USB port, plus a "USB to Serial Converter".

A.2. Step by step guide on installing the software to your PC.

1. Double click the "Setup J1939 Simulator Remote Terminal V2.00A" installation file, as shown in Figure A-1.



Figure A-1

2. Open file – security warning window pop up, click "Run" (Figure A-2)

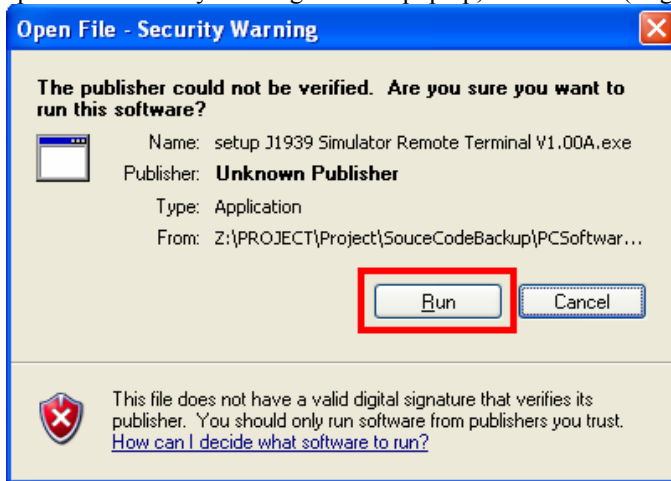

Figure A-2

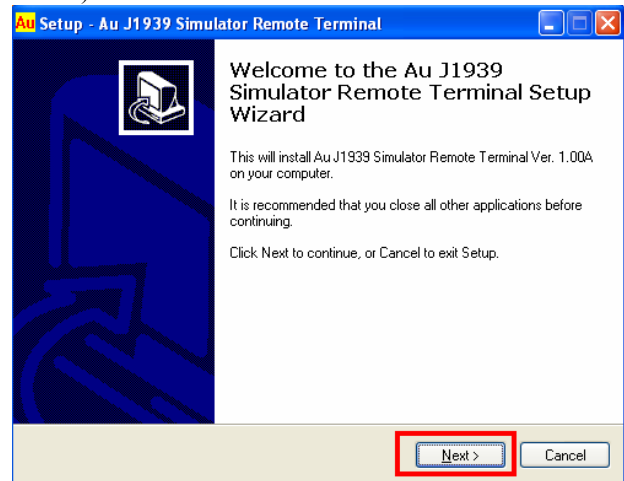

Figure A-3

3. "Welcome to the Au J1939 Simulator Remote Terminal Setup Wizard" window pop up, click "Next" to continue (Figure A-3).
4. "License Agreement" window pop up, please read the license agreement and select "I accept the agreement", click "Next" to continue (Figure A-4).

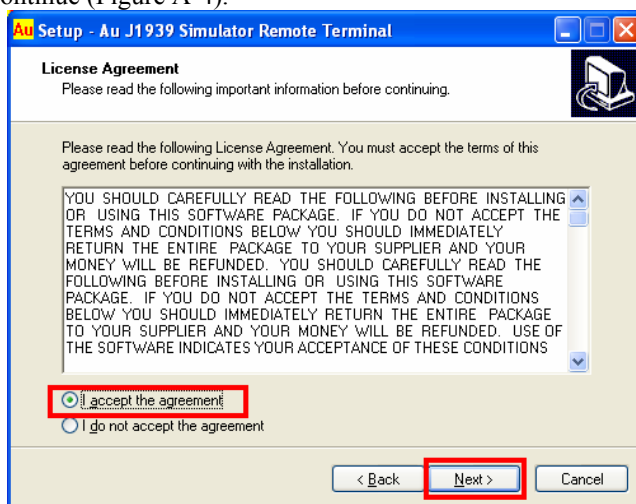

Figure A-4

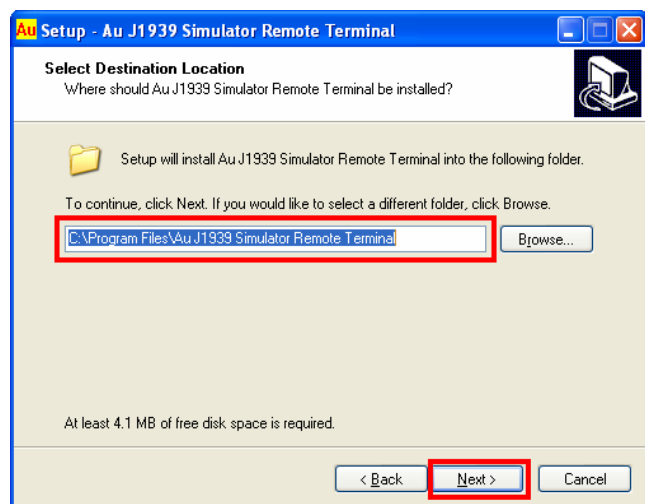

Figure A-5

5. "Select Destination Location" window pop up, use the default folder, and click "Next" to continue (Figure A-5).

6. “Select Start Menu Folder” window pop up, use the default folder and click “Next” to continue (Figure A-6).

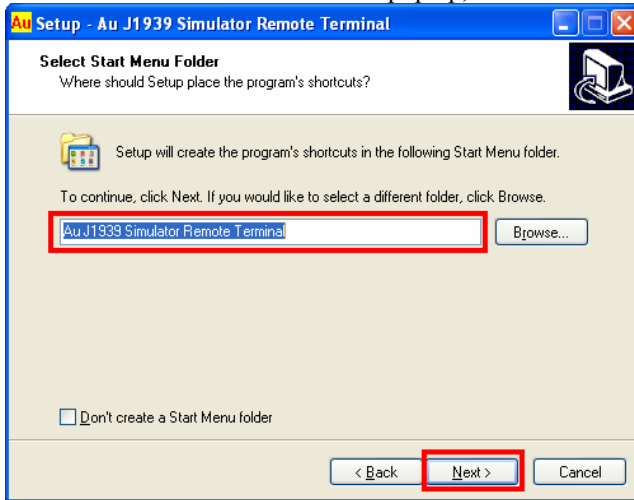

Figure A-6

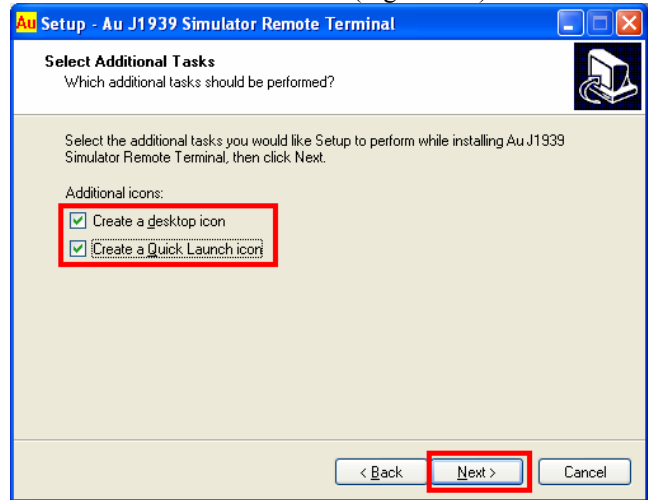

Figure A-7

7. “Select Additional Tasks” window pop up, check both “Create a desktop icon, and Create a Quick Launch icon”, click “Next” to continue (Figure A-7).

8. “Ready to Install” window pop up, click “Install” (Figure A-8)

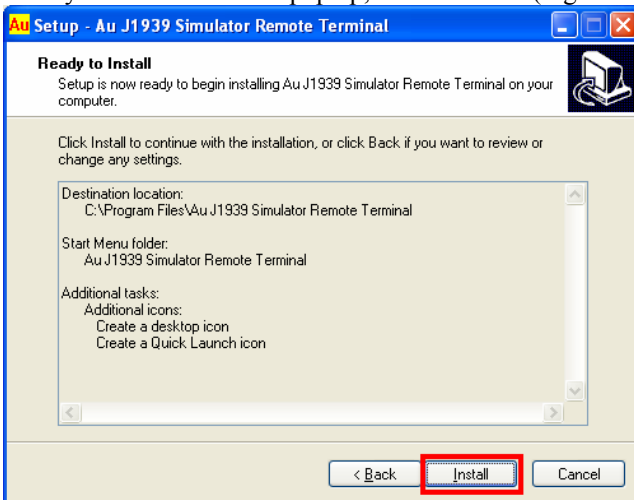

Figure A-8



Figure A-9

9. Check "launch Au J1939 Simulator Remote Terminal", click "Finish" (Figure A-9)

Appendix B - License Management Toolset

Au J1939 Simulator License Management Toolset enables user to upgrade Au J1939 Simulator from Basic Edition(s) to Platinum Edition(s) or Vehicle Edition in-field. For instance, an engine basic edition can be upgraded to an engine premium edition.

B.1. What you need for upgrade Au SAE-J1939 Simulator License.

1. Order new license code from the following web link:
<http://www.auelectronics.com/System-J1939Simulator.htm>
2. PC software: "AU J1939 Simulator License Management Toolset V2.00A" is included in the software disc when any Au J1939 Simulator is ordered.
3. A PC equipped with serial port and a serial extension cable or a PC equipped with USB port and a "USB to Serial Converter".

B.2. Step by Step License management Toolset Installation

Note: For any user had the License management Toolset installed on your PC before, please bypass step 1 to step 8, and start with step 9.

1. Double click the installation program of "AU setup J1939 Simulator License Management Toolset V2.00A", as shown in Figure B-1.



Figure B-1

2. "Welcome to Au J1939 simulator License Management Toolset Setup wizard" window shows up, click "next", as shown in Figure B-2
3. "License Agreement" window shows up, please read the license agreement and select "I accept the agreement", then click "next" (Figure B-3)

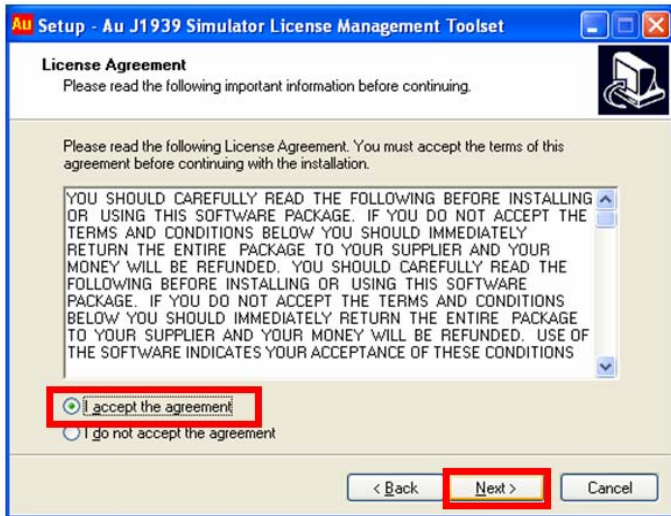

Figure B-2



Figure B-3

4. "Select Destination" window shows up, use default: C:\Program Files\ AU J1939 Simulator License Management Toolset", then click "next" (Figure B-4).
5. "Select Start Menu Folder" window shows up, use default setting "AU J1939 Simulator License Management Toolset", then click "next" (Figure B-5)

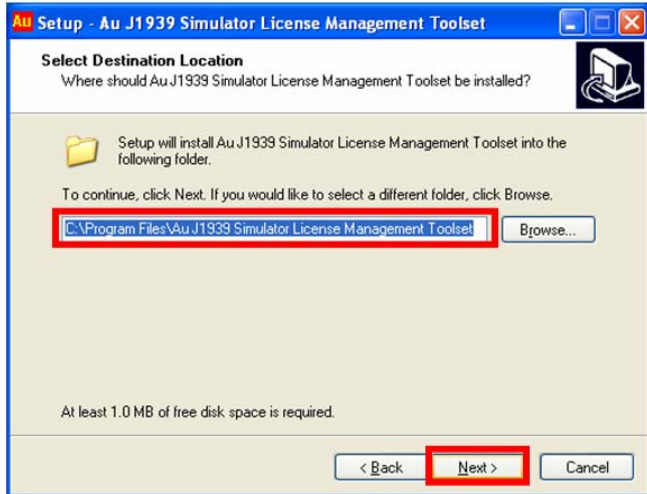

Figure B-4

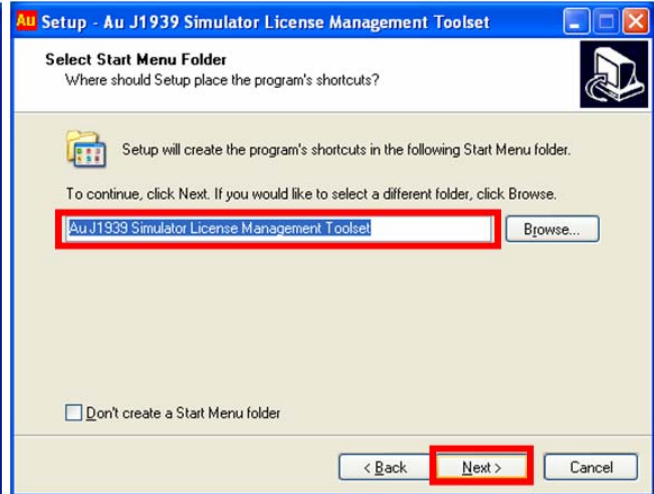

Figure B-5

6. "Select Additional Task" window shows up, check both "create a desktop icon" and "Create a quick launch icon", then click "next" (Figure B-6)
7. "Ready to Install" window shows up, click "Install", as shown in Figure B-7.

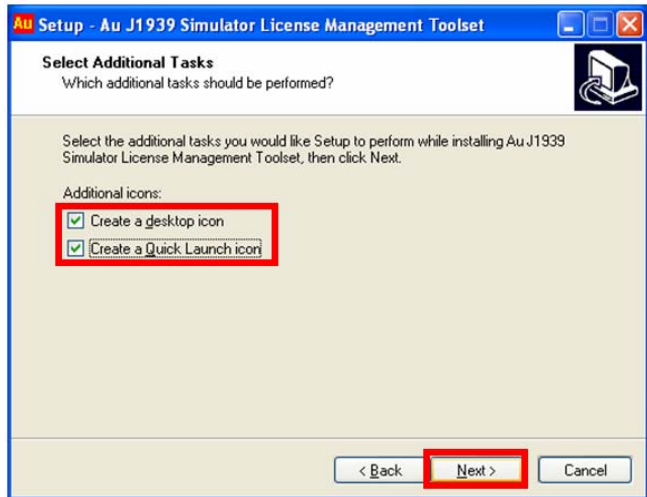

Figure B-6

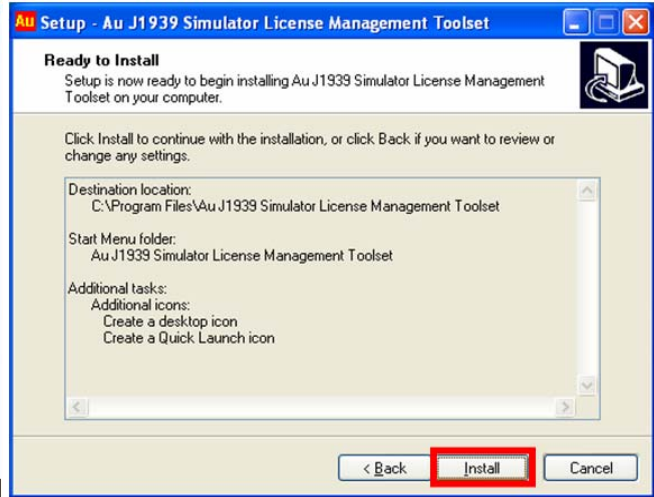

Figure B-7

8. Wait until "Completing Au J1939 Simulator License Management Toolset Setup Wizard" window shows up, check "launch Au J1939 Simulator License Management Toolset", then click "Finish" (Figure B-8, Figure B-9).



Figure B-8

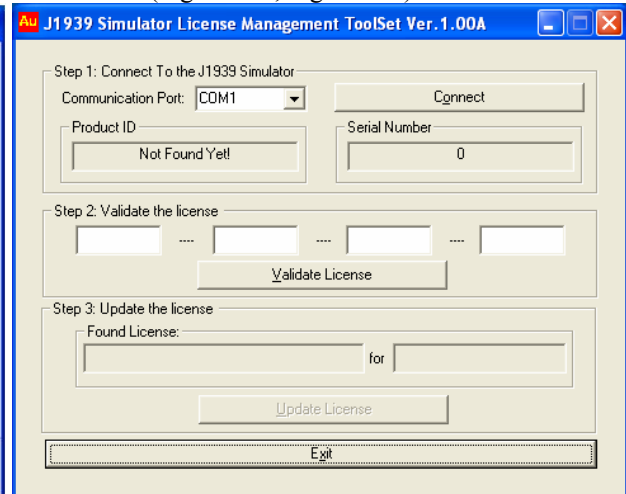

Figure B-9

B.3. Step by Step License Upgrading Procedure

Use a serial cable to connect PC with the J1939 simulator, and then proceed to next step.

1. Select a proper Serial Communication Port, e.g. COM1, which is used to connect Au J1939 Simulator, then click “Connect” button.

Au J1939 simulator ID and serial number will show up (Figure B-10). Notice that Product ID showing "Engine Basic" in this demonstration.

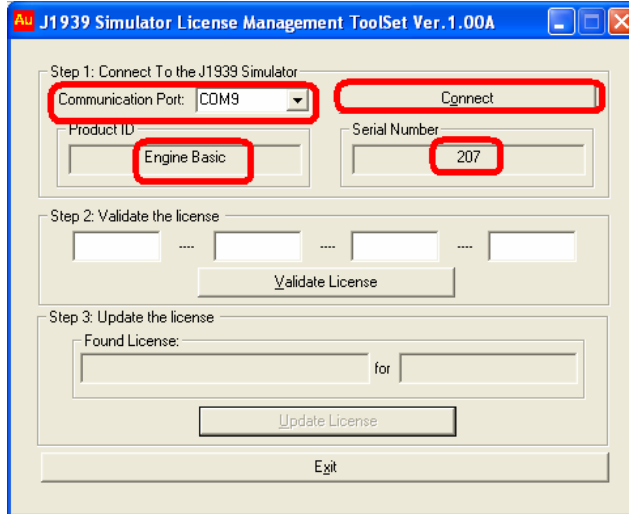

Figure B-10

Note: Each Au J1939 Simulator will have a unique Serial Number and may have a different Product ID (J1939 Simulator Edition).

2. Enter a validate license code in the license management toolset, then click “Validate license” button (Figure B-11)

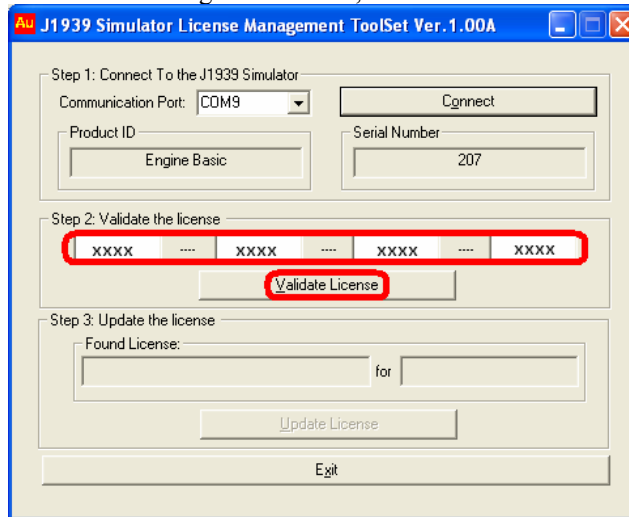

Figure B-11

3. Au J1939 Simulator License Toolset will check if entered license number is valid or not. If not, “the license is not for this product” message window will show up, click OK, “Sorry, Invalidate license!” then show up, click OK, (Figure B-12).

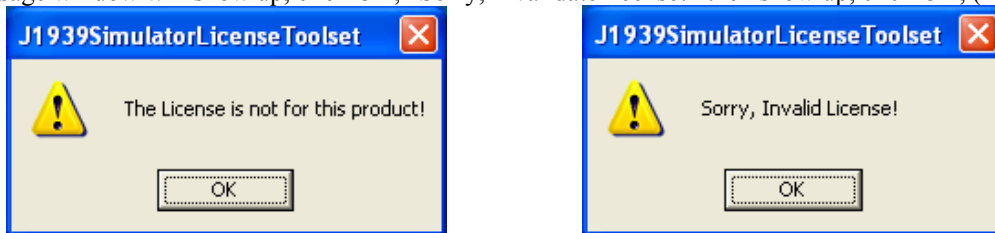

Figure B-12 – Warning message boxes show up if license is not valid

- After a validate license is entered, Au J1939 Simulator License Toolset will show the license information for the new license code, click “Update License” button (Figure B-13), Engine premium is demonstrated here.

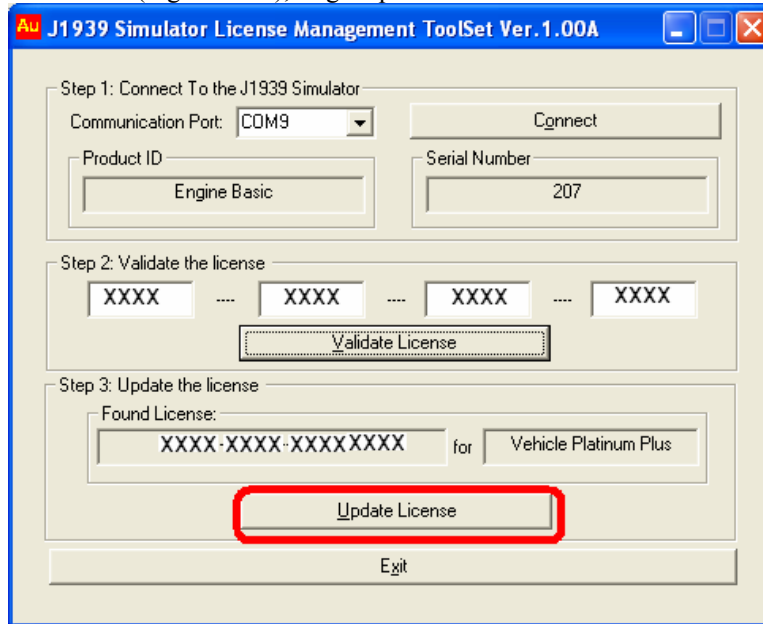

Figure B-13 Engine premium license validate

- When it is updated successfully, a beep will be heard. And Au J1939 Simulator License Toolset will show the new license (Engine premium in this demonstration), it means your product has been upgraded to engine premium edition successfully, click “Exit”, as shown in Figure B-14.

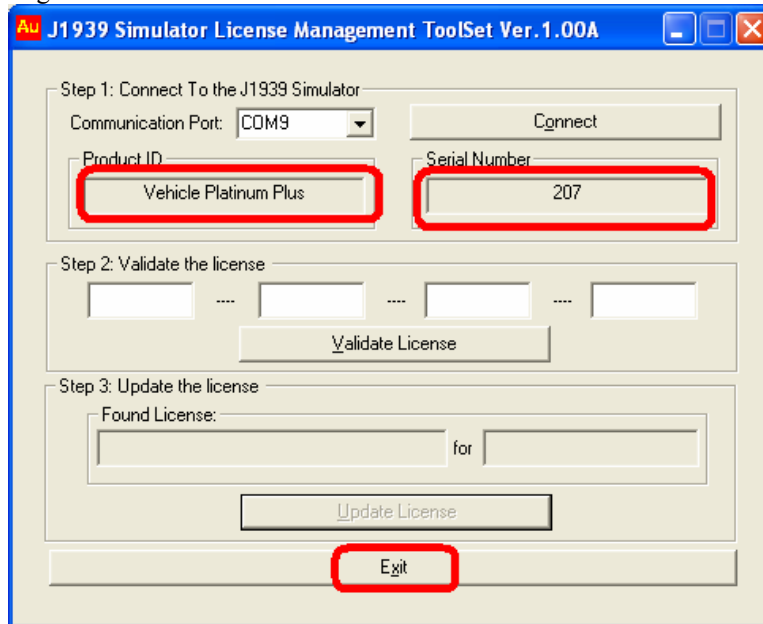

Figure B-14 Product updated to Engine premium successfully

Appendix C - Au PIC Serial Bootloader Application Note

C-1 What’s needed Before Install Au PIC Bootloader?

- A PC equipped with serial port or PC equipped with USB port + “USB to Serial Converter”.
- Serial cable to connect a PC to a PIC target board.
- Au PIC Bootloader installation program (it is available through Au Group Electronics)
- An encrypted PIC-code file with extension of "Aud" (it will be provided by Au Group Electronics for different products, e.g. SAE-J1939 simulator, etc.)

C-2 How to Install Au PIC Bootloader

Note: If the Au PIC Bootloader has been installed on PC before, please bypass step 1 to step 8, and start with step 9.

1. Double click icon of the “Setup Au PIC Bootloader V1.00B” to start installing Au PIC Bootloader (Figure C-1).



Figure C-1 - Setup Au PIC Bootloader V1.00A icon

2. “Welcome to the Au PIC Bootloader Setup Wizard” window show up, click “Next” (Figure C- 2)

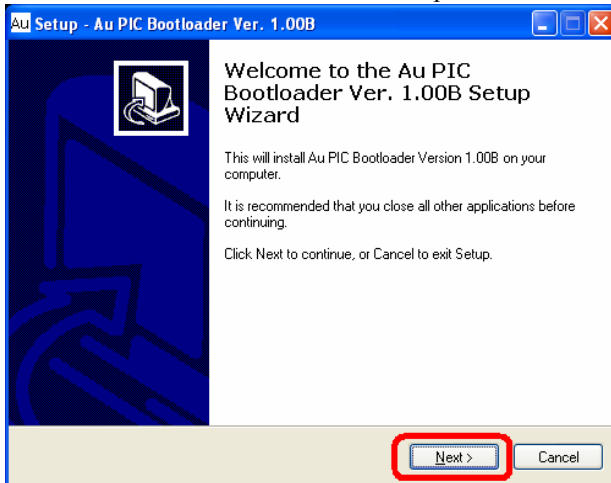

Figure C-2

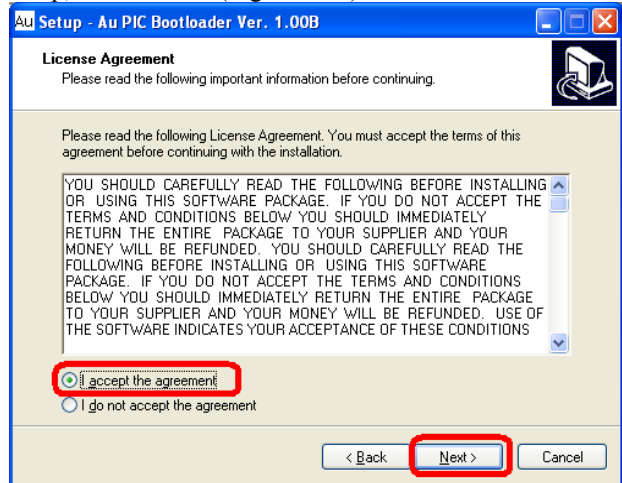

Figure C-3

3. “License Agreement” window show up, read the license agreement and select “I accept the agreement”, then click “Next” to continue (Figure C-3).
4. “Select Destination” window shows up, use default path: C:\Program Files\ AU PIC Bootloader”, then click “next” to continue (Figure C-4).

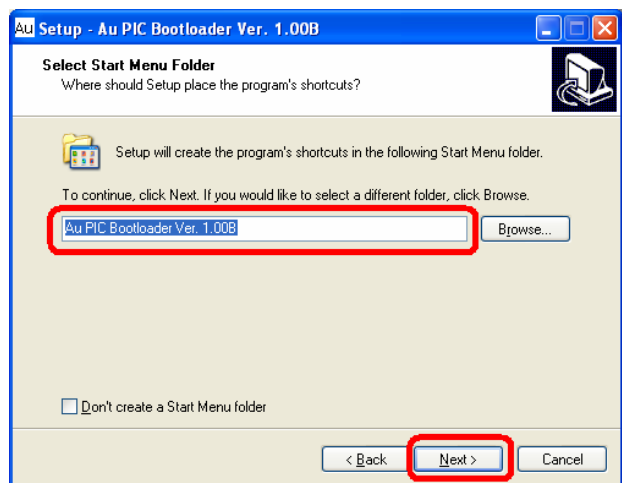
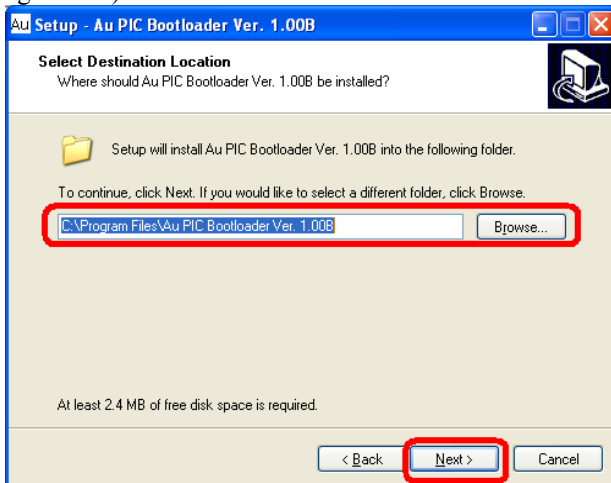

Figure C-4

Figure C-5

- “Select Start Menu Folder” window show up, use default setting “AU PIC Bootloader”, then click “next” (Figure C-5).
- “Select Additional Task” window shows up, check both “create a desktop icon” and “Create a quick launch icon”, and then click “next” to continue (Figure C-6).

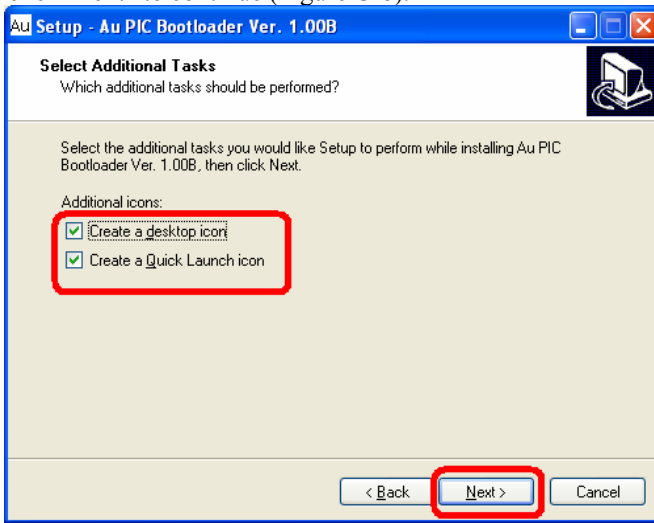

Figure C-6

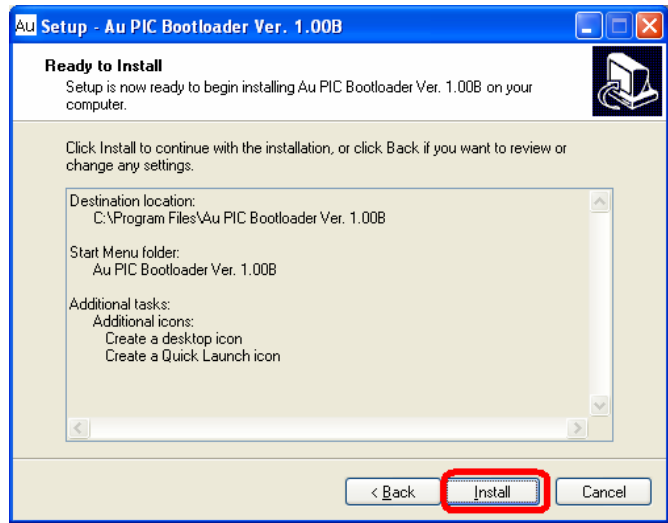

Figure C-7

- “Ready to Install” window shows up. Click “Install” (Figure C-7).
- After a few seconds, “Completing the Au PIC Bootloader Setup Wizard” window shows up, check “launch Au Bootloader”, click “Finish” to exit setup (Figure C-8).

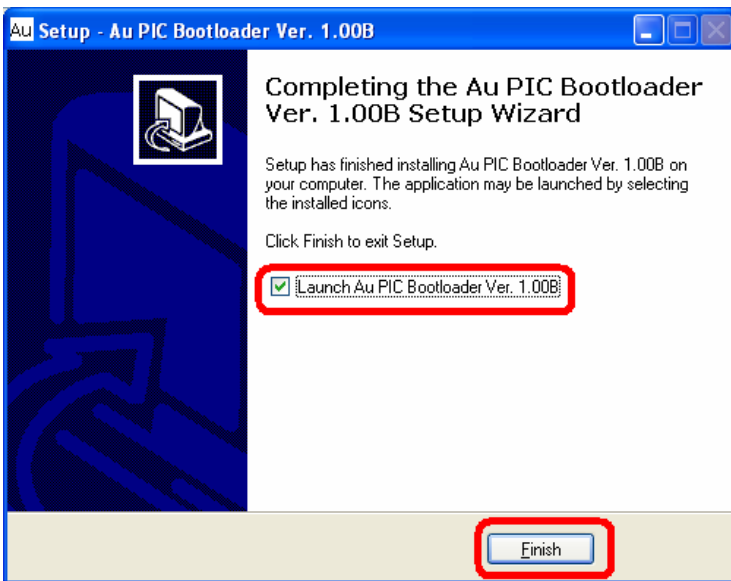

Figure C-8

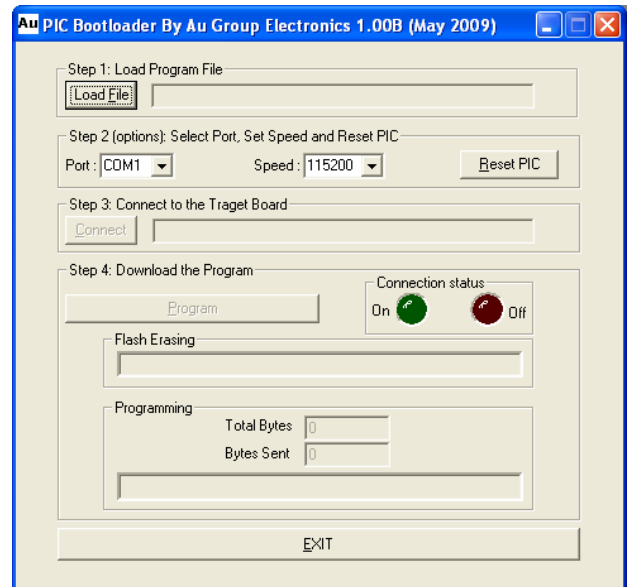

Figure C-9

- Au PIC18 Bootloader is launched, as shown in Figure C-9

C-3 How to Use Au PIC Bootloader

Step 1. Load Program File:

Connect Au SAE J1939 Simulator to a PC, then click “Load File” button (Figure C-10).

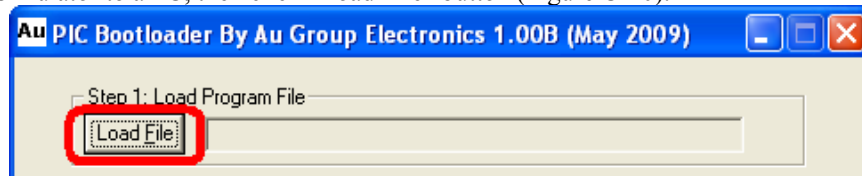

Figure C-10

Select file type with “.Aud” extension, then click “Open” (Figure C-11).

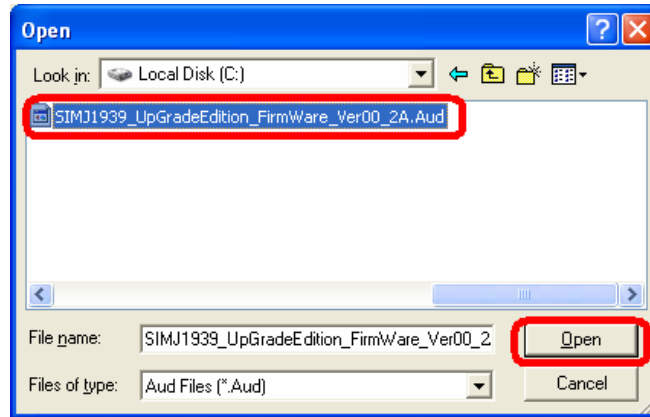

Figure C-11

Step 2. Select port, set speed, and Reset PIC

- Select proper serial communication port, which is used to connect with Au J1939 Simulator.
- Set the communication Baud Rate at 115200 bps, as shown in Figure C-12

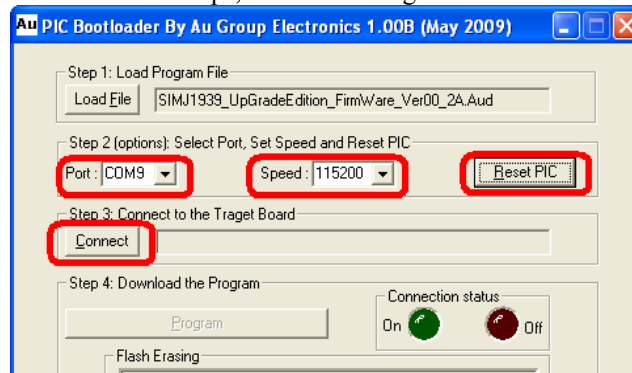

Figure C-12

- Trigger target board into Bootloader mode by one of the following 2 ways:

Hardware Trigger Method:

Press and hold **Menu** button on Au SAE-J1939 simulator, then connect +9~+12V DC power supply to Au J1939 Simulator, the "Warning" LED will blink indicating it has entered the Bootloader mode.

Software Trigger Method:

Connect +9~+12V DC power supply to Au J1939 Simulator at the "BUS" side, then click "Reset PIC" button on Au PIC Bootloader User Interface (Figure C-12). "Warning" LED will be blinking.

Step 3. Connect to target board

Within 10 seconds, click "Connect" button (Figure C-12).

Note: There is a 10 seconds time-out period to let the Bootloader program connecting to Au J1939 Simulator, if user failed to do so, please repeat step 2.

The "Warning" LED on Au J1939 Simulator will be constant on, also the connection status indicator – the Green light on Bootloader GUI will be on, notice that "Program" button now been activated, Also the target board PIC Bootloader information "Au-CB0301, F458, 20M, BTL232-E-001 1.00A" will show up, as shown in Figure C-13.

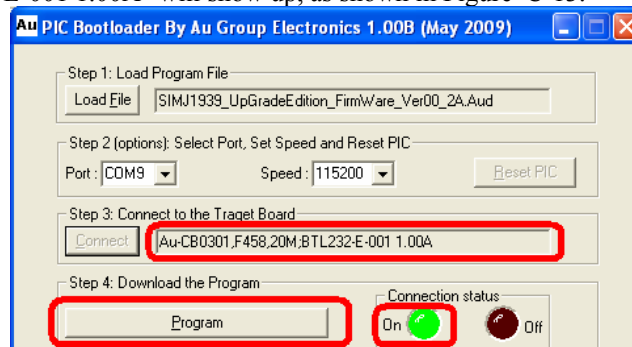

Figure C-13

Step 4. Download program to Au J1939 Simulator

Click “Program” button (Figure C-13).

The flash of the J1939 Simulator will be erased first, it takes a few seconds. Then the pre-loaded "xxxx.Aud" file will be programmed into Au J1939 Simulator, and the programming status will show up (Figure C-14).

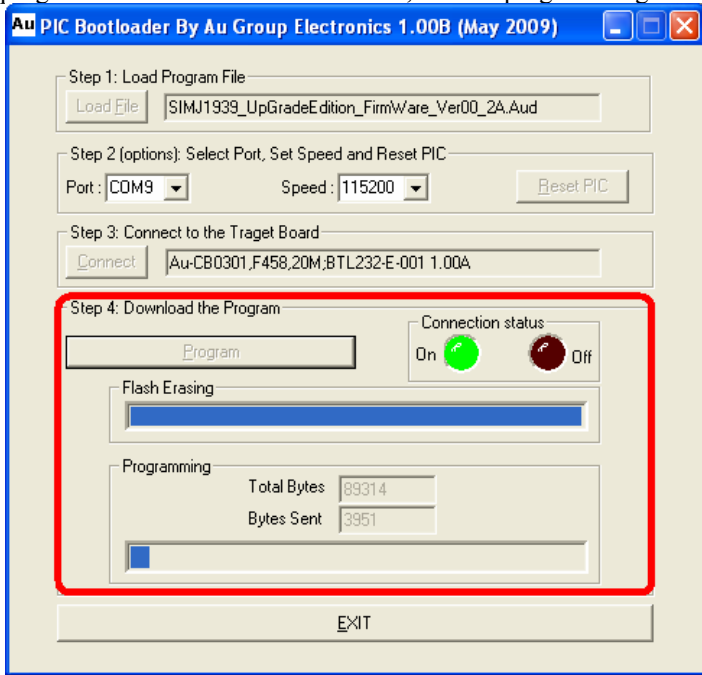

Figure C-14

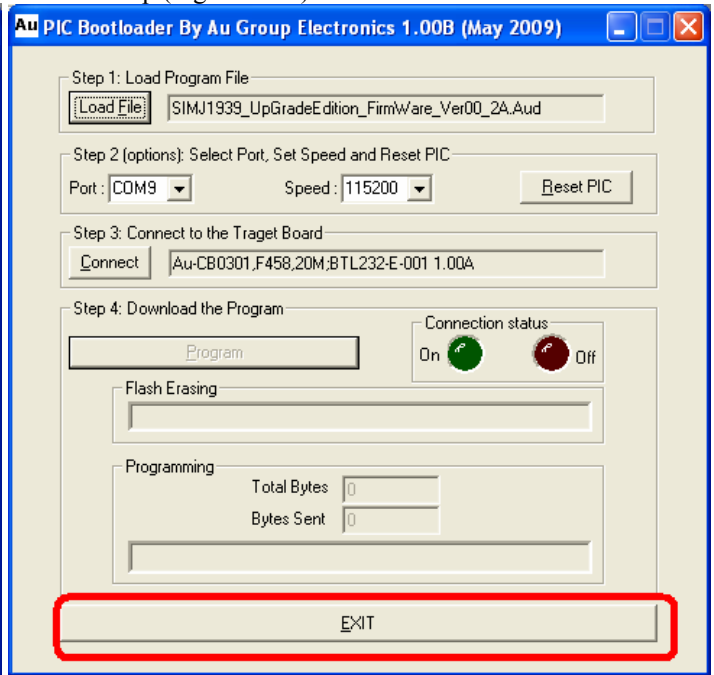

Figure C-15

This process may take a few minutes depending on the file size and communication speed. When programming finished, click “exit” to exit Bootloader mode (Figure C-15).

The Au J1939 Simulator should function normally with the new code now.

Appendix D - CAN Baud Rate Configuration Procedure

Au J1939 Simulator can be configured to the following 5 baud rate: 62.5K bps, 125K bps, 250K bps, 500K bps, 1M bps. The default factory setting of Au J1939 Simulator CAN Baud Rate is 250K bps. The following example illustrate on how to change the default CAN baud rate from 250K bps to 500K bps.

Video demonstration can be view from the link here: <https://youtu.be/J7ii7VnbSio>

D.1. Click Au icon on Au J1939 Simulator Remote Terminal GUI, then click "About J1939 Simulator Remote Terminal..." button from the list.

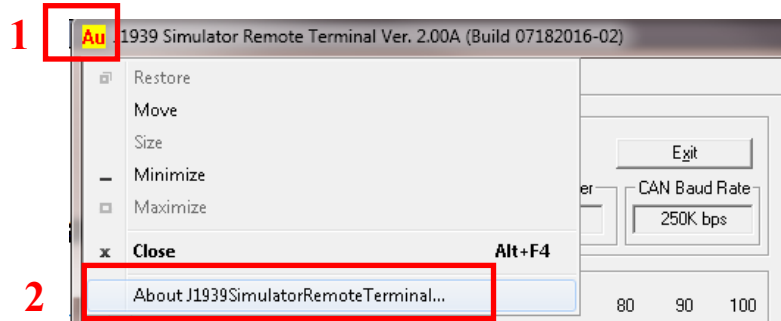

Figure D-1

D.2. Click "Proceed to Change CAN Baud Rate"

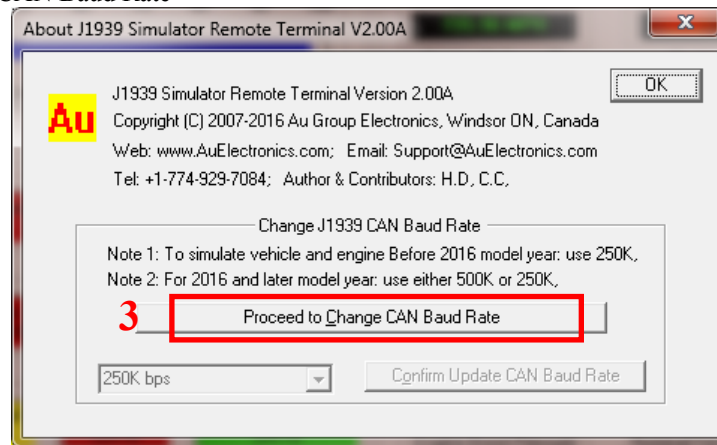

Figure D-2

D.3. Choose 500K bps from the drop down list, then click "Confirm Update CAN Baud Rate" button.

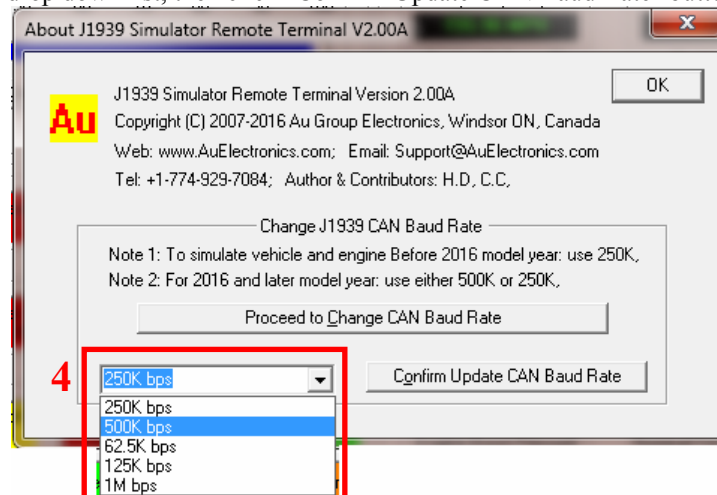

Figure D-3

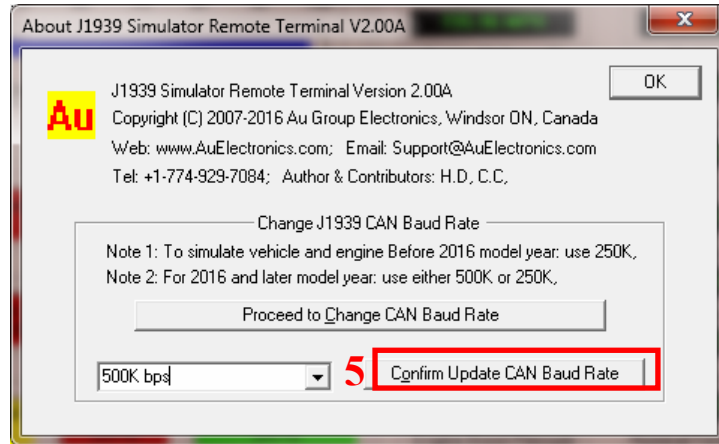

Figure D-4

D.4. Notice that the CAN Baud Rate now changed to 500K bps.

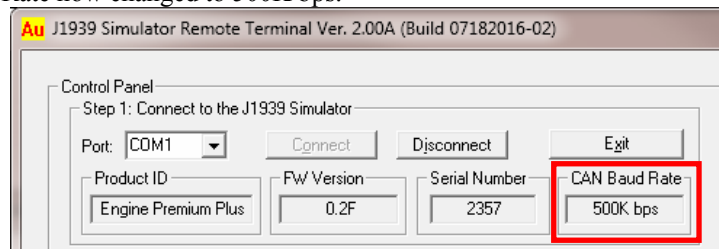

Figure D-5

Thank You

Thank you for choosing Au Group Electronics products.

Should you have any question or comments, please contact us at:
support@AuElectronics.com

Please visit our website for recent product releases and ordering products at:
www.AuElectronics.com

We look forward to serving you again in the near future.